

EXERCISE 16.3

PAGE NO: 16.14

1. By applying SAS congruence condition, state which of the following pairs (Fig. 28) of triangle are congruent. State the result in symbolic form

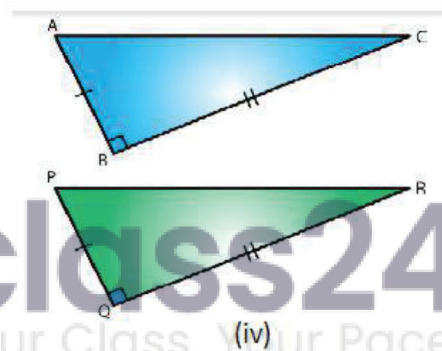
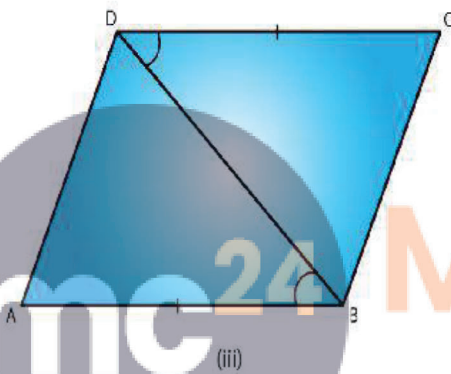
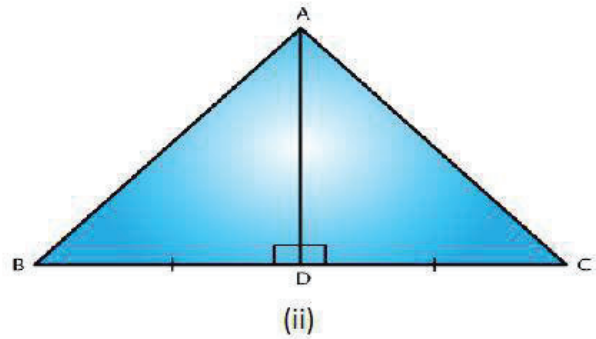
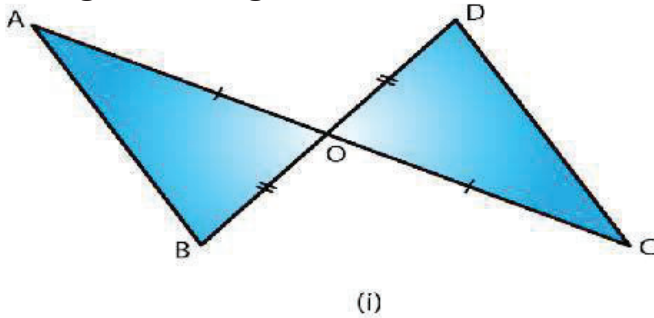

Fig. 28

Solution:

(i) From the figure we have $OA = OC$ and $OB = OD$ and $\angle AOB = \angle COD$ which are vertically opposite angles.
Therefore by SAS condition, $\triangle AOB \cong \triangle COD$

(ii) From the figure we have $BD = DC$
 $\angle ADB = \angle ADC = 90^\circ$ and $AD = DA$
Therefore, by SAS condition, $\triangle ADB \cong \triangle ADC$.

(iii) From the figure we have $AB = DC$
 $\angle ABD = \angle CDB$ and $BD = DB$
Therefore, by SAS condition, $\triangle ABD \cong \triangle CBD$

(iv) We have $BC = QR$
 $\angle ABC = \angle PQR = 90^\circ$
And $AB = PQ$

Therefore, by SAS condition, $\triangle ABC \cong \triangle PQR$.

2. State the condition by which the following pairs of triangles are congruent.

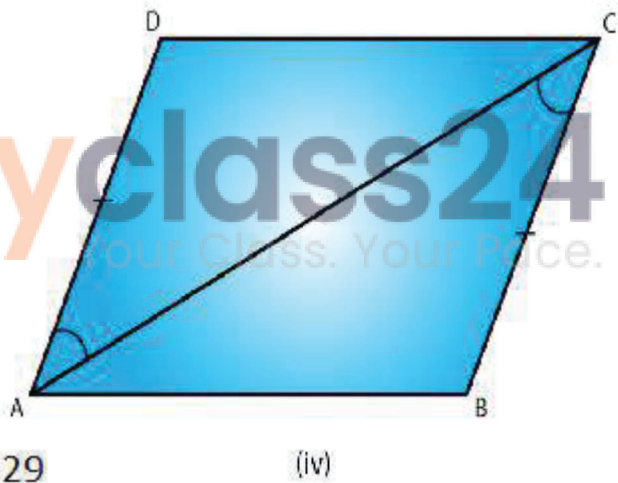
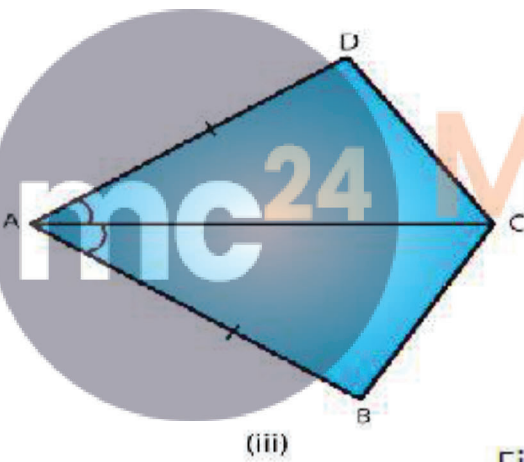
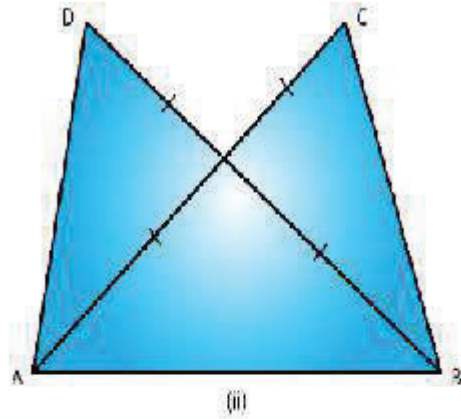
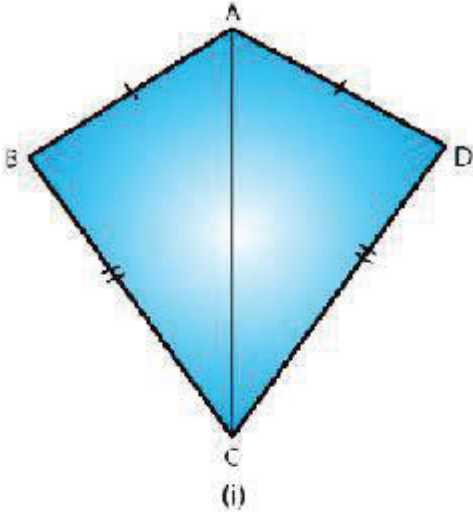

Fig. 29

Solution:

(i) $AB = AD$

$BC = CD$ and $AC = CA$

Therefore by SSS condition, $\triangle ABC \cong \triangle ADC$

(ii) $AC = BD$

$AD = BC$ and $AB = BA$

Therefore, by SSS condition, $\triangle ABD \cong \triangle BAC$

(iii) $AB = AD$

$\angle BAC = \angle DAC$ and $AC = CA$

Therefore by SAS condition, $\triangle BAC \cong \triangle DAC$

(iv) $AD = BC$
 $\angle DAC = \angle BCA$ and $AC = CA$
Therefore, by SAS condition, $\triangle ABC \cong \triangle ADC$

3. In fig. 30, line segments AB and CD bisect each other at O. Which of the following statements is true?

- (i) $\triangle AOC \cong \triangle DOB$
- (ii) $\triangle AOC \cong \triangle BOD$
- (iii) $\triangle AOC \cong \triangle ODB$

State the three pairs of matching parts, you have used to arrive at the answer.

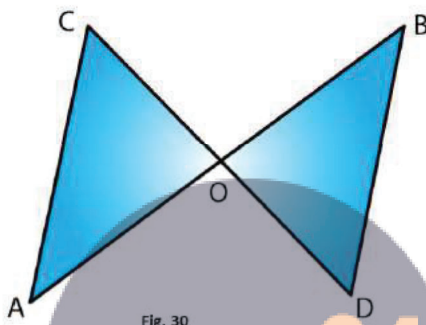

Fig. 30

Solution:

From the figure we have,

$$AO = OB$$

$$\text{And, } CO = OD$$

$$\text{Also, } \angle AOC = \angle BOD$$

Therefore, by SAS condition, $\triangle AOC \cong \triangle BOD$

Hence, (ii) statement is true.

4. Line-segments AB and CD bisect each other at O. AC and BD are joined forming triangles AOC and BOD. State the three equality relations between the parts of the two triangles that are given or otherwise known. Are the two triangles congruent? State in symbolic form, which congruence condition do you use?

Solution:

We have $AO = OB$ and $CO = OD$

Since AB and CD bisect each other at O.

$$\text{Also } \angle AOC = \angle BOD$$

Since they are opposite angles on the same vertex.

Therefore by SAS congruence condition, $\Delta AOC \cong \Delta BOD$

5. ΔABC is isosceles with $AB = AC$. Line segment AD bisects $\angle A$ and meets the base BC in D .

(i) Is $\Delta ADB \cong \Delta ADC$?

(ii) State the three pairs of matching parts used to answer (i).

(iii) Is it true to say that $BD = DC$?

Solution:

(i) We have $AB = AC$ (Given)

$\angle BAD = \angle CAD$ (AD bisects $\angle BAC$)

Therefore by SAS condition of congruence, $\Delta ADB \cong \Delta ADC$

(ii) We have used $AB, AC; \angle BAD = \angle CAD; AD, DA$.

(iii) Now, $\Delta ADB \cong \Delta ADC$

Therefore by corresponding parts of congruent triangles

$BD = DC$.

6. In Fig. 31, $AB = AD$ and $\angle BAC = \angle DAC$.

(i) State in symbolic form the congruence of two triangles ABC and ADC that is true.

(ii) Complete each of the following, so as to make it true:

(a) $\angle ABC =$

(b) $\angle ACD =$

(c) Line segment AC bisects And

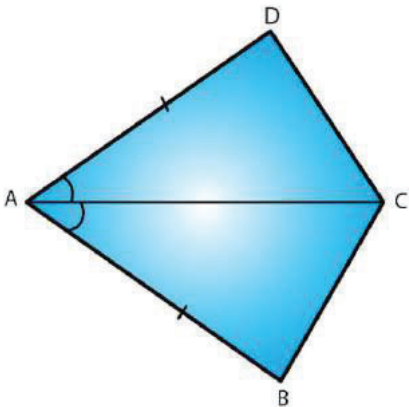

Fig. 31

Solution:

i) $AB = AD$ (given)

$\angle BAC = \angle DAC$ (given)

$AC = CA$ (common)

Therefore by SAS condition of congruency, $\triangle ABC \cong \triangle ADC$

ii) $\angle ABC = \angle ADC$ (corresponding parts of congruent triangles)

$\angle ACD = \angle ACB$ (corresponding parts of congruent triangles)

Line segment AC bisects $\angle A$ and $\angle C$.

7. In fig. 32, $AB \parallel DC$ and $AB = DC$.

(i) Is $\triangle ACD \cong \triangle CAB$?

(ii) State the three pairs of matching parts used to answer (i).

(iii) Which angle is equal to $\angle CAD$?

(iv) Does it follow from (iii) that $AD \parallel BC$?

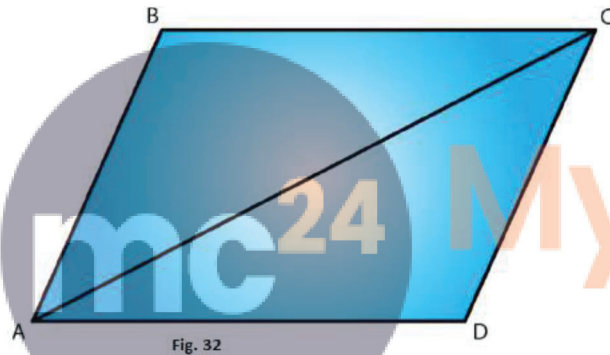

Solution:

(i) Yes by SAS condition of congruency, $\triangle ACD \cong \triangle CAB$.

(ii) We have used $AB = DC$, $AC = CA$ and $\angle DCA = \angle BAC$.

(iii) $\angle CAD = \angle ACB$ since the two triangles are congruent.

(iv) Yes this follows from AD parallel to BC as alternate angles are equal. If alternate angles are equal then the lines are parallel