

# 1. Number System

## Exercise 1.1

### 1. Question

Is zero a rational number? Can you write it in the form  $\frac{p}{q}$ , where  $p$  and  $q$  are integers and  $q \neq 0$ ?

### Answer

Yes, zero is a rational number, It can be written in the form of  $\frac{p}{q}$  where  $q \neq 0$  such as  $\frac{0}{3}, \frac{0}{5}, \frac{0}{11}$ , etc.

### 2. Question

Find five rational numbers between 1 and 2.

### Answer

**Given:** to find five rational numbers between 1 and 2, we multiply & divide both the numbers by 6.

**Trick:** To find "n" rational numbers between any two numbers "a" & "b", just multiply & divide the numbers "a" & "b" by "n+1".

Example,

To find five rational numbers between 1 and 2, we multiply & divide both the numbers by 6, as shown:

$$1 \times \frac{6}{6} = \frac{6}{6}$$

$$\text{And, } 2 \times \frac{6}{6} = \frac{12}{6}$$

Therefore, five rational numbers between 1 and 2 are:

$$\frac{7}{6}, \frac{8}{6}, \frac{9}{6}, \frac{10}{6}, \frac{11}{6}$$

### 3. Question

Find six rational numbers between 3 and 4.

### Answer

Given, to find six rational numbers between 3 and 4.

We have,

$$3 * \frac{7}{7} = \frac{21}{7} \text{ and } 4 * \frac{7}{7} = \frac{28}{7}$$

We know that,

$$21 < 22 < 23 < 24 < 25 < 26 < 27 < 28$$

$$\text{required rational numbers} = \frac{21}{7} < \frac{22}{7} < \frac{23}{7} < \frac{24}{7} < \frac{25}{7} < \frac{26}{7} < \frac{27}{7} < \frac{28}{7}$$

$$= 3 < \frac{22}{7} < \frac{23}{7} < \frac{24}{7} < \frac{25}{7} < \frac{26}{7} < \frac{27}{7} < 4$$

Hence, 6 rational numbers between 3 and 4 are:

$$\frac{22}{7}, \frac{23}{7}, \frac{24}{7}, \frac{25}{7}, \frac{26}{7}, \frac{27}{7}$$

#### 4. Question

Find five rational numbers between  $\frac{3}{5}$  and  $\frac{4}{5}$ .

#### Answer

Given, to find 5 rational numbers between  $\frac{3}{5}$  and  $\frac{4}{5}$

$$\text{We have, } \frac{3}{5} \times \frac{6}{6} = \frac{18}{30} \text{ and } \frac{4}{5} \times \frac{6}{6} = \frac{24}{30}$$

We know that,

$$18 < 19 < 20 < 21 < 22 < 23 < 24$$

$$= \frac{18}{30} < \frac{19}{30} < \frac{20}{30} < \frac{21}{30} < \frac{22}{30} < \frac{23}{30} < \frac{24}{30}$$

$$= \frac{3}{5} < \frac{19}{30} < \frac{20}{30} < \frac{21}{30} < \frac{22}{30} < \frac{23}{30} < \frac{4}{5}$$

$$= \frac{3}{5} < \frac{19}{30} < \frac{2}{3} < \frac{7}{10} < \frac{11}{15} < \frac{23}{30} < \frac{4}{5}$$

Hence, 5 rational numbers between  $\frac{3}{5}$  and  $\frac{4}{5}$  are:

$\frac{19}{30}, \frac{2}{3}, \frac{7}{10}, \frac{11}{15}, \frac{23}{30}$  Note: You can multiply and divide with any number you want to find the rational numbers.

#### 5. Question

Are the following statements true or false? Give reasons for your answer.

- (i) Every whole number is a natural number.
- (ii) Every integer is a rational number.
- (iii) Every rational number is an integer.
- (iv) Every natural number is a whole number.
- (v) Every integer is a whole number.
- (vi) Every rational number is a whole number

## Answer

(i) False: As whole numbers include zero, whereas natural numbers doesn't include zero.

(ii) True: As integers are a part of rational numbers.

(iii) False: As integers are a part of natural numbers.

(iv) True: As whole numbers include all the natural numbers.

(v) False: As whole numbers are a part of integers.

(vi) False: As rational numbers include all the whole numbers.

## Exercise 1.2

### 1. Question

Express the following rational numbers as decimals:

(i)  $\frac{42}{100}$  (ii)  $\frac{327}{500}$  (iii)  $\frac{15}{4}$

### Answer

(i) By long division

$$\begin{array}{r} 0.42 \\ 100 \overline{) 42.00} \\ \underline{400} \phantom{00} \\ 200 \phantom{00} \\ \underline{200} \\ 0 \end{array}$$

$$\therefore \frac{42}{100} = 0.42$$

(ii) By long division method, we have

$$\begin{array}{r} 0.654 \\ 500 \overline{) 327.000} \\ \underline{3000} \phantom{00} \\ 2700 \phantom{00} \\ \underline{2500} \phantom{00} \\ 2000 \phantom{00} \\ \underline{2000} \\ 0 \end{array}$$

$$\frac{327}{500} = 0.654$$

(iii) By long division method, we have

**Myclass24**  
Your Class. Your Pace.

$$\begin{array}{r}
 3.75 \\
 4 \overline{)15.00} \\
 \underline{12} \phantom{00} \\
 30 \phantom{0} \\
 \underline{28} \phantom{0} \\
 20 \phantom{0} \\
 \underline{20} \\
 0
 \end{array}$$

$$\therefore \frac{15}{4} = 3.75$$

## 2. Question

Express the following rational numbers as decimals:

$$(i) \frac{2}{3} \quad (ii) -\frac{4}{9} \quad (iii) -\frac{2}{15} \quad (iv) -\frac{22}{13} \quad (v) \frac{437}{999} \quad (vi) \frac{33}{26}$$

### Answer

(i) By long division method, we have

$$\begin{array}{r}
 0.6666 \\
 3 \overline{)2.000} \\
 \underline{18} \phantom{00} \\
 20 \phantom{0} \\
 \underline{18} \phantom{0} \\
 20 \phantom{0} \\
 \underline{18} \phantom{0} \\
 2
 \end{array}$$

$$\therefore \frac{2}{3} = 0.666\dots = 0.\bar{6}$$

(ii) By long division method, we have

$$\begin{array}{r}
 0.4444 \\
 9 \overline{)4.0000} \\
 \underline{36} \phantom{00} \\
 40 \phantom{0} \\
 \underline{36} \phantom{0} \\
 40 \phantom{0} \\
 \underline{36} \phantom{0} \\
 4
 \end{array}$$

$$\therefore \frac{4}{9} = 0.4444\dots = 0.\bar{4}$$

(iii) By long division method, we have

**Myclass24**  
Your Class. Your Pace.

$$\begin{array}{r}
 0.133 \\
 15 \overline{) 2.0000} \\
 \underline{15} \phantom{000} \\
 50 \phantom{00} \\
 \underline{45} \phantom{00} \\
 50 \phantom{0} \\
 \underline{45} \\
 6
 \end{array}$$

$$\therefore \frac{2}{15} = 0.133 = 0\overline{13}$$

(iv) By long division method, we have

$$\begin{array}{r}
 1.6923076923 \\
 13 \overline{) 22.0000} \\
 \underline{13} \phantom{0000} \\
 90 \phantom{00} \\
 \underline{78} \phantom{00} \\
 120 \phantom{0} \\
 \underline{117} \phantom{0} \\
 30 \phantom{0} \\
 \underline{26} \phantom{0} \\
 40 \phantom{0} \\
 \underline{39} \phantom{0} \\
 100 \phantom{0} \\
 \underline{91} \phantom{0} \\
 98 \phantom{0} \\
 \underline{78} \phantom{0} \\
 120 \phantom{0} \\
 \underline{117} \phantom{0} \\
 3
 \end{array}$$

$$\therefore \frac{23}{13} = 1.6923076923\dots = 1.\overline{692307}$$

(v) By long division method, we have

$$\begin{array}{r}
 0.43743 \\
 999 \overline{) 437.000000} \\
 \underline{3996} \phantom{000} \\
 3740 \phantom{00} \\
 \underline{2997} \phantom{00} \\
 7430 \phantom{0} \\
 \underline{6993} \phantom{0} \\
 4370 \phantom{0} \\
 \underline{3996} \phantom{0} \\
 3740 \phantom{0} \\
 \underline{2997} \phantom{0} \\
 743
 \end{array}$$

$$\therefore \frac{437}{999} = 0.43743\dots = 0.\overline{437}$$

**Myclass24**  
Your Class. Your Pace.

(vi) By long division method, we have

$$\begin{array}{r}
 1.2692307692 \\
 26 \overline{) 33.00000000} \\
 \underline{26} \phantom{00000000} \\
 70 \phantom{00000000} \\
 \underline{52} \phantom{00000000} \\
 180 \phantom{0000000} \\
 \underline{156} \phantom{0000000} \\
 240 \phantom{000000} \\
 \underline{234} \phantom{000000} \\
 60 \phantom{000000} \\
 \underline{52} \phantom{000000} \\
 80 \phantom{000000} \\
 \underline{78} \phantom{000000} \\
 200 \phantom{00000} \\
 \underline{182} \phantom{00000} \\
 180 \phantom{00000} \\
 \underline{156} \phantom{00000} \\
 24
 \end{array}$$

$$\therefore \frac{33}{26} = 1.269230769... = 1.\overline{2692307}$$

### 3. Question

Look at several examples of rational numbers in the form  $\frac{p}{q}$  ( $q \neq 0$ ), where  $p$  and  $q$  are integers with no common factors other than 1 and having terminating, decimal representations. Can you guess what property  $q$  must satisfy?

#### Answer

A rational number  $\frac{p}{q}$  is a terminating decimal only, when prime factors of  $q$  are 2 and 5 only.

Therefore,  $\frac{p}{q}$  is a terminating decimal only, when prime factorisation of  $q$  must have only powers of 2 or 5 or both.

### Exercise 1.3

#### 1. Question

Express each of the following decimals in the form  $\frac{p}{q}$ :

(i) 0.39 (ii) 0.750 (iii) 2.15 (iv) 7.010 (v) 9.90 (vi) 1.0001

#### Answer

To convert decimal into fraction count no of decimal places in decimal number. Let it be  $x$ . Then multiply and divide the decimal number with  $10^x$ (i) We have,

$$0.39 = \frac{39}{100}$$

(ii) We have,

$$0.750 = \frac{750}{1000} = \frac{750 \div 250}{1000 \div 250}$$

$$= \frac{3}{4}$$

(iii) We have,

$$2.15 = \frac{215}{100} = \frac{215 \div 5}{100 \div 5} = \frac{43}{20}$$

(iv) We have,

$$7.010 = \frac{7010}{1000} = \frac{7010 \div 10}{1000 \div 10}$$

$$= \frac{701}{100}$$

(v) We have,

$$9.90 = \frac{990}{100} = \frac{990 \div 10}{100 \div 10}$$

$$= \frac{99}{10}$$

(vi) We have,

$$1.0001 = \frac{10001}{10000}$$

## 2. Question

Express each of the following decimals in the form  $\frac{p}{q}$ :

- (i)  $0.\bar{4}$  (ii)  $0.\bar{37}$  (iii)  $0.\bar{54}$  (iv)  $0.\bar{621}$  (v)  $125.\bar{3}$  (vi)  $4.\bar{7}$  (vii)  $0.4\bar{7}$

### Answer

(i) Let  $x = 0.\bar{4}$

Now,  $x = 0.\bar{4} = 0.444\dots$  (1)

Multiplying both sides of equation (1) by 10, we get,

$$10x = 4.444\dots$$
 (2)

Subtracting equation (1) by (2)

$$10x - x = 4.444\dots - 0.444\dots$$

$$9x = 4$$

$$x = \frac{4}{9}$$

Hence,  $0.\bar{4} = \frac{4}{9}$

(ii) Let  $x = 0.\bar{37}$

Now,  $x = 0.3737\dots$  (1)

Multiplying equation (1) by 10

$$10x = 3.737\dots \text{ (2)}$$

Multiplying equation (2) by 10

$$100x = 37.3737\dots \text{ (3)}$$

$$100x - x = 37$$

$$99x = 37$$

$$x = \frac{37}{99}$$

Hence,  $0.\overline{37} = \frac{37}{99}$

(iii) Now  $x = 0.\overline{54}$

$$= 0.5454\dots \text{ (i)}$$

Multiplying both sides of equation (i) by 100, we get

$$100x = 54.5454\dots \text{ (ii)}$$

Subtracting (i) by (ii), we get

$$100x - x = 54.5454\dots - 0.5454\dots$$

$$99x = 54$$

$$x = \frac{54}{99}$$

(iv) Now  $x = 0.\overline{621}$

$$= 0.621621\dots \text{ (i)}$$

Multiplying both sides by 1000, we get

$$1000x = 621.621621\dots \text{ (ii)}$$

Subtracting (i) by (ii), we get

$$1000x - x = 621.621621\dots - 0.621621\dots$$

$$999x = 621$$

$$x = \frac{621}{999} = \frac{23}{37}$$

(v) Now  $x = 125.\overline{3}$

$$= 125.3333\dots \text{ (i)}$$

Multiplying both sides of equation (i) by 10, we get

$$10x = 1253.3333\dots \text{ (ii)}$$

Subtracting (i) by (ii), we get

$$10x - x = 1253.3333\dots - 125.3333\dots$$

$$9x = 1128$$

$$x = 1128 / 9 = 376/3$$

(vi) Now  $x = 4.\bar{7}$

$$= 4.7777\dots \text{ (i)}$$

Multiplying both sides of equation (i) by 10, we get

$$10x = 47.7777\dots \text{ (ii)}$$

$$10x - x = 47.7777\dots - 4.7777\dots$$

$$9x = 43$$

$$x = \frac{43}{9}$$

(vii) Now,  $x = 0.4\bar{7}$

$$= 0.47777\dots$$

Multiplying both sides by 10, we get

$$10x = 4.7777\dots \text{ (i)}$$

Multiplying both sides of equation (i) by 10, we get

$$100x = 47.7777\dots \text{ (ii)}$$

Subtracting (i) from (ii), we get

$$100x - 10x = 47.7777\dots - 4.7777\dots$$

$$90x = 43$$

$$x = \frac{43}{90}$$

## Exercise 1.4

### 1. Question

Define an irrational number.

### Answer

A number which can neither be expressed as a terminating decimal nor as a repeating decimal is called an irrational number. For example,

1.01001000100001...

### 2. Question

Explain, how irrational numbers differ from rational numbers?

## Answer

A number which can neither be expressed as a terminating decimal nor as a repeating decimal is called an irrational number. For example,

0.33033003300033...

On the other hand, every rational number is expressible either as a terminating decimal or as a repeating decimal. For example,  $3.2\bar{4}$  and  $6.2876$  are rational numbers.

## 3. Question

Examine, whether the following numbers are rational or irrational:

(i)  $\sqrt{7}$  (ii)  $\sqrt{4}$  (iii)  $2 + \sqrt{3}$  (iv)  $\sqrt{3} + \sqrt{2}$

(v)  $\sqrt{3} + \sqrt{5}$  (vi)  $(\sqrt{2} - 2)^2$  (vii)  $(2 - \sqrt{2})(2 + \sqrt{2})$  (viii)  $(\sqrt{2} + \sqrt{3})^2$

(ix)  $\sqrt{5} - 2$  (x)  $\sqrt{23}$  (xi)  $\sqrt{225}$  (xii) 0.3796 (xiii) 7.478478

(xiv) 1.101001000100001.....

## Answer

(i)  $\sqrt{7}$  is not a perfect square root, so it is an irrational number.

(ii) We have,

$$\sqrt{4} = 2 = \frac{2}{1}$$

$\sqrt{4}$  can be expressed in the form of  $\frac{p}{q}$ , so it is a rational number.

*The decimal expression of  $\sqrt{4}$  is 2.0*

(iii) 2 is a rational number, whereas  $\sqrt{3}$  is an irrational number.

Because, sum of a rational number and an irrational number is an irrational number, so  $2 + \sqrt{3}$  is an irrational number

(iv)  $\sqrt{2}$  is an irrational number. Also  $\sqrt{3}$  is an irrational number. The sum of two irrational numbers is irrational.

Therefore,  $\sqrt{3} + \sqrt{2}$  is an irrational number.

(v)  $\sqrt{5}$  is an irrational number. Also,  $\sqrt{3}$  is an irrational number. The sum of two irrational numbers is irrational.

Therefore,  $\sqrt{3} + 5$  is an irrational number.

(vi) We have,

$$\begin{aligned}(\sqrt{2} - \sqrt{2})^2 &= (\sqrt{2})^2 - 2 * \sqrt{2} * 2 + (2)^2 \\ &= 2 - 4\sqrt{2} + 4\end{aligned}$$

$$= 6 - 4\sqrt{2}$$

Now 6 is a rational number, whereas  $4\sqrt{2}$  is an irrational number

The difference of a rational number and an irrational number is an irrational number.

So, it is an irrational number.

(vii) We have,

$$\begin{aligned}(2 - \sqrt{2})(2 + \sqrt{2}) &= (2)^2 - (\sqrt{2})^2 \text{ [Therefore, } (a - b)(a + b) = a^2 - b^2\text{]} \\ &= 4 - 2 = 2 = \frac{2}{1}\end{aligned}$$

Since 2 is a rational number

Therefore,  $(2 - \sqrt{2})(2 + \sqrt{2})$  is a rational number

(viii) We have,

$$\begin{aligned}(\sqrt{2} + \sqrt{3})^2 &= (\sqrt{2})^2 + 2 \times \sqrt{2} \times \sqrt{3} + (\sqrt{3})^2 \\ &= 2 + 2\sqrt{6} + 3 \\ &= 5 + 2\sqrt{6}\end{aligned}$$

The sum of a rational number and an irrational number is irrational number. Therefore, it is an irrational number.

(ix) The difference of a rational number and an irrational number is an irrational number.

Therefore,  $5 - \sqrt{2}$  is an irrational number.

$$(x) \sqrt{23} = 4.79583152331\dots$$

Therefore, it is an irrational number

$$(xi) \sqrt{225} = 15 = \frac{15}{1}$$

Therefore, it is a rational number as it is represented in the form of  $\frac{p}{q}$ , where  $q \neq 0$

(xii) 0.3796, as a decimal expansion of this number is terminating, so it is a rational number.

$$(xiii) 7.478478\dots = 7.\overline{478}$$

As, decimal expansion of this number is non – terminating recurring so it is a rational number

$$(xiv) 1.101001000100001\dots$$

It is an irrational number

#### 4. Question

Identify the following as rational or irrational numbers. Give the decimal representation of rational numbers:

(i)  $\sqrt{4}$  (ii)  $3\sqrt{18}$  (iii)  $\sqrt{1.44}$  (iv)  $\sqrt{\frac{9}{27}}$  (v)  $-\sqrt{64}$  (vi)  $\sqrt{100}$

**Answer**

(i)  $\sqrt{4} = 2 = \frac{2}{1}$

$\sqrt{4}$  can be written in the form of  $\frac{p}{q}$ , so it is a rational number.

Its decimal expansion is 2.0

(ii)  $3\sqrt{18} = 3\sqrt{2 * 3 * 3}$

$= 3 * 3\sqrt{2}$

$= 9\sqrt{2}$

Since, the product of a rational and an irrational is an irrational number.

Therefore,  $9\sqrt{2}$  is an irrational;

$3\sqrt{18}$  is an irrational number

(iii) We have,

$\sqrt{1.44} = \frac{12}{10}$

$\square = 1.2$

Every terminating decimal is a rational number, so 1.2 is a rational number.

(iv) we have,

$\sqrt{\frac{9}{27}} = \frac{3}{\sqrt{27}} = \frac{3}{\sqrt{3*3*3}}$

$= \frac{1}{3}$

Quotient of a rational and an irrational number is irrational number. Therefore, it is an irrational number.

(v)  $-\sqrt{64} = -\sqrt{8} * 8$

$= -8 = -8/1$

AS it can be expressed in the form of  $\frac{p}{q}$ , so it is a rational number.

(vi)  $\sqrt{100} = 10 = \frac{10}{1}$

Thus it can be expressed in the form of  $\frac{p}{q}$ , so it is a rational number.

## 5. Question

In the following equations, find which variables  $x$ ,  $y$ ,  $z$  etc. represent rational or

(i)  $x^2 = 5$  (ii)  $y^2 = 9$  (iii)  $z^2 = 0.04$  (iv)  $u^2 = \frac{17}{4}$  (v)  $v^2 = 3$  (vi)  $w^2 = 27$  (vii)  $t^2 = 0.4$

**Answer**

(i) We have,

$$x^2 = 5$$

Taking square root on both sides,

$$= \sqrt{x^2} = \sqrt{5}$$

$$= x = \sqrt{5}$$

$\sqrt{5}$  is not a perfect square root, so it is an irrational number.

(ii) We have,

$$y^2 = 9$$

$$y = \sqrt{9}$$

$$= 3 = \frac{3}{1}$$

$\sqrt{9}$  can be expressed in the form of  $\frac{p}{q}$ , so it is a rational number.

(iii) We have,

$$z^2 = 0.04$$

Taking square root on both the sides, we get,

$$\sqrt{z^2} = \sqrt{0.04}$$

$$z = \sqrt{0.04}$$

$$= 0.2 = \frac{2}{10}$$

$$= \frac{1}{5}$$

$z$  can be expressed in the form of  $\frac{p}{q}$ , so it is a rational number.

(iv) We have,

$$u^2 = \frac{17}{4}$$

Taking square root on both the sides, we get

$$\sqrt{u^2} = \frac{\sqrt{17}}{\sqrt{4}}$$

$$u = \frac{\sqrt{17}}{\sqrt{2}}$$

Quotient of an rational number is irrational, so u is an irrational number.

(v) We have,

$$v^2 = 3$$

Taking square roots on both the sides, we get,

$$\sqrt{v^2} = \sqrt{3}$$

$$v = \sqrt{3}$$

$\sqrt{3}$  is not a perfect square root, so v is an irrational number.

(vi) We have,

$$w^2 = 27$$

Taking square roots on both the sides, we get,

$$\sqrt{w^2} = \sqrt{27}$$

$$w = \sqrt{3} * \sqrt{3} * \sqrt{3} = 3\sqrt{3}$$

Product of a rational number and an irrational number is irrational number. So, it is an irrational number.

(vii) We have,

$$t^2 = 0.4$$

Taking square roots on both the sides, we get,

$$\sqrt{t^2} = \sqrt{0.4} = \frac{\sqrt{4}}{\sqrt{10}}$$

$$= \frac{2}{\sqrt{10}}$$

Since, quotient of a rational number and an irrational number is irrational number, so t is an irrational number.

## 6. Question

Give an example of each, of two irrational numbers whose:

- (i) Difference is a rational number.
- (ii) Difference is an irrational number.
- (iii) Sum is a rational number.
- (iv) Sum is an irrational number.
- (v) Product is a rational number.

(vi) Product is an irrational number.

(vii) Quotient is a rational number.

(viii) Quotient is an irrational number.

**Answer**

(i)  $\sqrt{3}$  is an irrational number.

$$\text{Now, } (\sqrt{3}) - (\sqrt{3}) = 0$$

0 is the rational number.

(ii) Let two irrational numbers are  $5\sqrt{2}$  and  $\sqrt{2}$

$$\text{Now, } (5\sqrt{2}) - (\sqrt{2}) = 4\sqrt{2}$$

$4\sqrt{2}$  is an irrational number.

(iii) Let two irrational numbers be  $\sqrt{11}$  and  $-\sqrt{11}$

$$\text{Now, } (\sqrt{11}) + (-\sqrt{11}) = 0$$

0 is a rational number

(iv) Let two irrational numbers are  $4\sqrt{6}$  and  $\sqrt{6}$

$$\text{Now, } (4\sqrt{6}) + (\sqrt{6}) = 5\sqrt{6}$$

$5\sqrt{6}$  is an irrational number.

(v) Let two irrational numbers are  $2\sqrt{3}$  and  $\sqrt{3}$

$$\text{Now, } 2\sqrt{3} * \sqrt{3} = 2 * 3$$

$$= 6$$

6 is a rational number.

(vi) Let two irrational numbers are  $\sqrt{2}$  and  $\sqrt{5}$

$$\text{Now, } \sqrt{2} * \sqrt{5} = \sqrt{10}$$

$\sqrt{10}$  is a irrational number.

(vii) Let two irrational numbers are  $3\sqrt{6}$  and  $\sqrt{6}$

$$\text{Now, } \frac{3\sqrt{6}}{\sqrt{6}} = 3$$

# is a rational number.

(viii) Let two irrational numbers are  $\sqrt{6}$  and  $\sqrt{2}$

$$\text{Now, } \frac{\sqrt{6}}{\sqrt{2}} = \frac{\sqrt{3} \cdot \sqrt{2}}{\sqrt{2}}$$

$$= \sqrt{3}$$

$\sqrt{3}$  is an irrational number.

### 7. Question

Give two rational numbers lying between 0.232332333233332.... and 0.212112111211112.

#### Answer

Let  $a = 0.212112111211112$

And,  $b = 0.232332333233332....$

Clearly  $a < b$  because in the second decimal place  $a$  has digit 1 and  $b$  has digit 3

If we consider rational numbers in which decimal place has the digit 2, then they will lie between  $a$  and  $b$

Let,

$$x = 0.22$$

$$y = 0.22112211...$$

Then,

$$a < x < y < b$$

Hence,  $x$  and  $y$  are required rational numbers.

### 8. Question

Give two rational numbers lying between 0.515115111511115.... and 0.5353353335....

#### Answer

Let  $a = 0.515115111511115....$

$b = 0.5353353335....$

We observe that the second decimal place  $a$  has digit 1 and  $b$  has digit 3, therefore,  $a < b$ . So if we consider rational numbers

$$x = 0.52$$

$$y = 0.52052052$$

Then,

$$a < x < y < b$$

Hence,  $x$  and  $y$  are required rational numbers.

### 9. Question

Find one irrational number between 0.2101 and 0.2222 .... =  $0.\bar{2}$  .

**Answer**

Let  $a = 0.2101$

And,  $b = 0.2222\dots$

We observe that the second decimal place  $a$  has digit 1 and  $b$  has digit 2, therefore,  $a < b$ . In the third decimal place  $a$  has digit 0. So, if we consider irrational number

$x = 0.211011001100011\dots$

We find that,

$a < x < b$

Hence,  $x$  is required irrational number.

**10. Question**

Find a rational number and also irrational number lying between the numbers  $0.3030030003\dots$  and  $0.3010010001\dots$

**Answer**

Let  $a = 0.3010010001\dots$

And,  $b = 0.3030030003\dots$

We observe that the second decimal place  $a$  has digit 1 and  $b$  has digit 3, therefore,  $a < b$ . In the third decimal place  $a$  has digit 1. So, if we consider rational and irrational numbers

$x = 0.302$

$y = 0.302002000200002\dots$

We find that,

$a < x < b$

And,  $a < y < b$

Hence,  $x$  and  $y$  are required rational and irrational numbers respectively.

**11. Question**

Find two irrational numbers between 0.5 and 0.55.

**Answer**

Let  $a = 0.5 = 0.50$

And,  $b = 0.55$

We observe that in the second decimal place  $a$  has digit 0 and  $b$  has digit 5. Therefore  $a < b$ . So, if we consider irrational numbers

$x = 0.51051005100051\dots$

$y = 0.5305343055353530\dots$

We find that,

$$a < x < y < b$$

Hence, x and y are required irrational numbers.

### 12. Question

Find two irrational numbers lying between 0.1 and 0.12.

### Answer

$$\text{Let, } a = 0.1 = 0.10$$

$$\text{And, } b = 0.12$$

We observe that in the second decimal place a has digit 0 and b has digit 2. Therefore  $a < b$ . So, if we consider irrational numbers

$$x = 0.11011001100011\dots$$

$$y = 0.111011110111110\dots$$

We find that,

$$a < x < y < b$$

Hence, x and y are required irrational numbers.

### 13. Question

Prove that  $\sqrt{3} + \sqrt{5}$  is an irrational number.

### Answer

If possible, let  $\sqrt{3} + \sqrt{5}$  be a rational number equal to x. Then,

$$x = \sqrt{3} + \sqrt{5}$$

$$x^2 = (\sqrt{3} + \sqrt{5})^2$$

$$= (\sqrt{3})^2 + (\sqrt{5})^2 + 2 * \sqrt{3} * \sqrt{5}$$

$$= 3 + 5 + 2\sqrt{15}$$

$$= 8 + 2\sqrt{15}$$

$$x^2 - 8 = 2\sqrt{15}$$

$$\frac{x^2 - 8}{2} = \sqrt{15}$$

Now, x is rational

$x^2$  is rational

$\frac{x^2 - 8}{2}$  is rational

$\sqrt{15}$  is rational

But,  $\sqrt{15}$  is irrational

Thus, we arrive at a contradiction. So, our supposition that  $\sqrt{3} + \sqrt{5}$  is rational is wrong.

Hence,  $\sqrt{3} + \sqrt{5}$  is an irrational number.

#### 14. Question

Find three different irrational numbers between the rational numbers  $\frac{5}{7}$  and  $\frac{9}{11}$ .

#### Answer

$$\frac{5}{7} = 0.714285$$

$$\frac{9}{11} = 0.81$$

3 irrational numbers are:

0.73073007300073000073.....

0.75075007500075000075....

0.79079007900079000079....

#### Exercise 1.5

##### 1. Question

Complete the following sentences:

- (i) Every point on the number line corresponds to a .....number which may be either ..... or .....
- (ii) The decimal form of an irrational number is neither..... nor....
- (iii) The decimal representation of a rational number is either ..... or .....
- (iv) Every real number is either ..... number or ..... number.

#### Answer

- (i) Every point on the number line corresponds to a REAL number which may be either RATIONAL or IRRATIONAL
- (ii) The decimal form of an irrational number is neither TERMINATING Nor REPEATING.
- (iii) The decimal representation of a rational number is either TERMINATING or NON TERMINATING
- (iv) Every real number is either RATIONAL number or IRRATIONAL Number

##### 2. Question

Represent  $\sqrt{6}, \sqrt{7}, \sqrt{8}$  on the number line.

#### Answer

Draw a number line and mark point O, representing zero, on it.

Then, for representing  $\sqrt{6}$ .

Step 1: On point A, 2 unit distance away from O,

Step 2: Draw a perpendicular to number line of 1 unit distance (as taken on number line).

Step 3: Mark the point as B.

Step 4: Join B to O. line OB represent  $\sqrt{5}$ .

Step 5: Put compass on O and B and by taking the radius cut number line with one needle still on O.

Step 6: Mark point as  $A_1$ . This line  $OA_1$  represent  $\sqrt{6}$ .

Step 7: Now draw 1 unit long perpendicular on  $A_1$ . And mark the end point as  $B_1$ .

Step 8: Now  $OB_1$  represent  $\sqrt{7}$ .

Step 9: By following Step 5 now cut  $\sqrt{7}$  on number line.

Step 10: For  $\sqrt{8}$  Draw perpendicular on  $\sqrt{7}$  on number line and follow above steps.

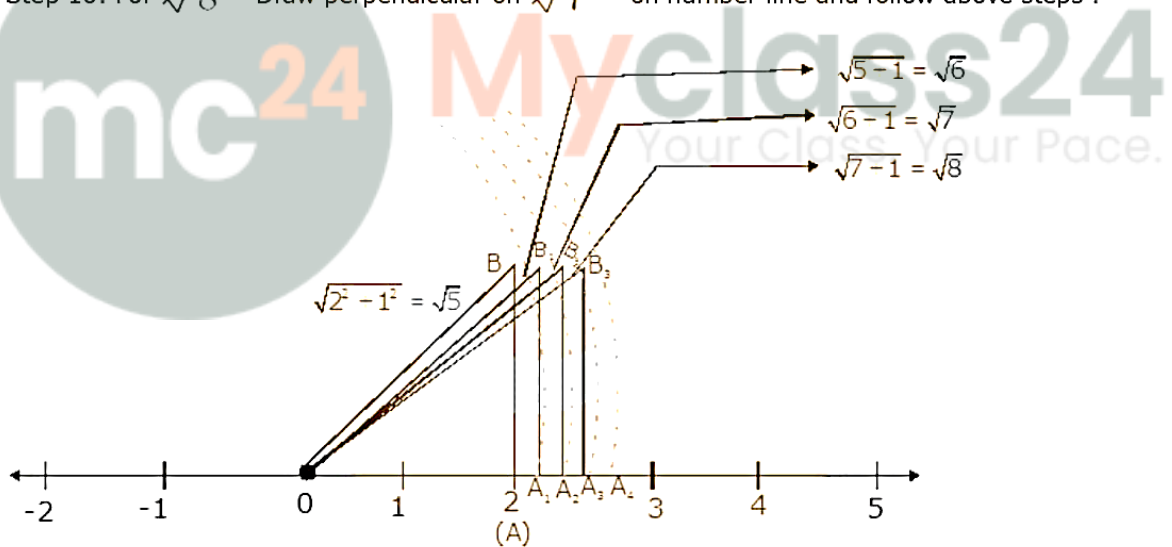

### 3. Question

Represent  $\sqrt{3.5}, \sqrt{9.4}, \sqrt{10.5}$  on the real number line.

### Answer

To represent  $\sqrt{3.5}$  on number line follow the following steps:

Step 1- Draw a line and mark a point A on it.

Step 2- Mark a point B on the line such that  $AB=3.5$  units.

Step 3- Mark a point C on AB produced such that BC=1 unit.

Step 4- Find the mid-point of AC. Let it be O

Step 5- Taking O as the centre and OC=OA as radius draw a semi circle. Also draw a line passing through B perpendicular to OB. Suppose it cuts the semi circle at D.

Step 6- Taking B as centre and BD as radius draw an arc cutting OC produced at E. Point E so obtained represents  $\sqrt{3.5}$

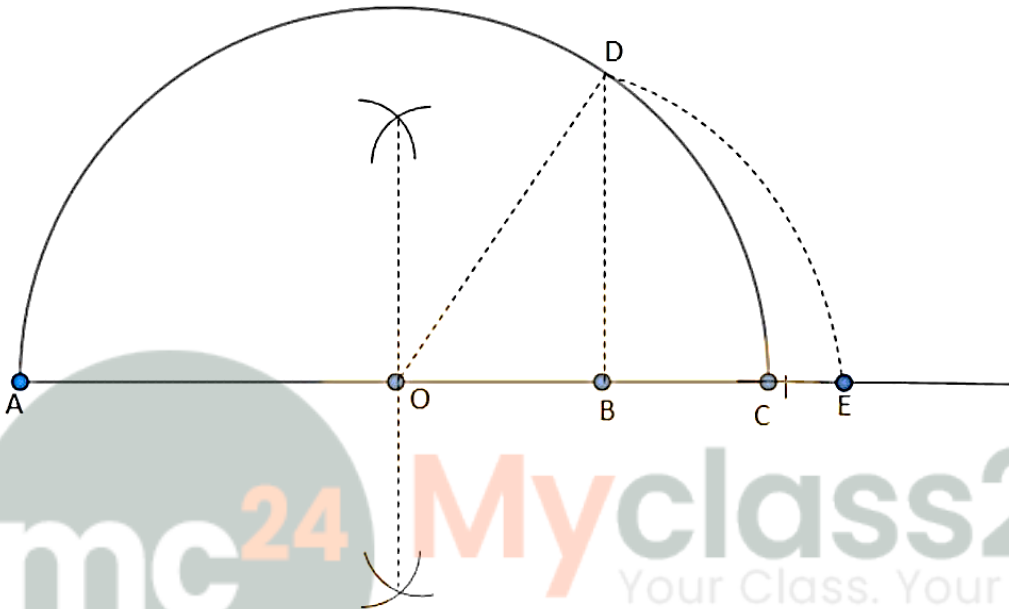

Similarly, represent other square root numbers on number line.

#### 4. Question

Find whether the following statements are true or false.

- (i) Every real number is either rational or irrational.
- (ii)  $\pi$  is an irrational number.
- (iii) Irrational numbers cannot be represented by points on the number line.

#### Answer

- (i) True: As we know that rational and irrational numbers taken form the set of real numbers.
- (ii) True: As,  $\pi$  is ratio of the circumference of a circle to its diameter, it is an irrational number.

$$\pi = \frac{2\pi r}{2r}$$

- (iii) False: Irrational numbers can be represented by point on the number line.

#### Exercise 1.6

##### 1. Question

Visualise 2.665 on the number line, using successive magnification.

### Answer

The following steps for successive magnification to visualise 2.665 are:

(1) We observe that 2.665 is located somewhere between 2 and 3 on the number line. So, let us look at the portion of the number line between 2 and 3.

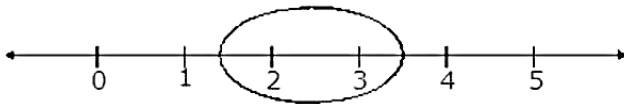

(2) We divide this portion into 10 equal parts and mark each point of division. The first mark to the right of 2 will represent 2.1, the next 2.2 and soon. Again we observe that 2.665 lies between 2.6 and 2.7.

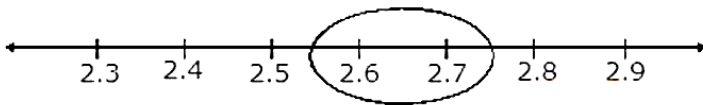

(3) We mark these points  $A_1$  and  $A_2$  respectively. The first mark on the right side of  $A_1$ , will represent 2.61, the number 2.62, and soon. We observe 2.665 lies between 2.66 and 2.67.

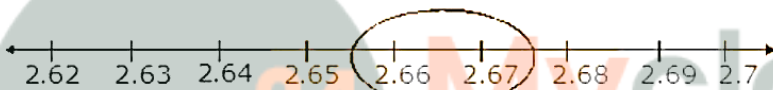

(4) Let us mark 2.66 as  $B_1$  and 2.67 as  $B_2$ . Again divide the  $B_1B_2$  into ten equal parts. The first mark on the right side of  $B_1$  will represent 2.661, then next 2.662, and so on.

Clearly, fifth point will represent 2.665.

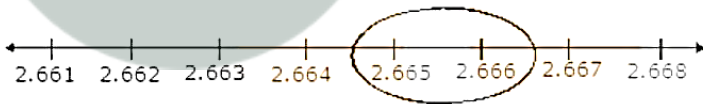

### 2. Question

Visualise the representation of  $5.3\bar{7}$  on the number line up to 5 decimal places that is up to 5.37777.

### Answer

Once again we proceed by successive magnification, and successively decrease the lengths of the portions of the number line in which  $5.3\bar{7}$  is located. First, we see that  $5.3\bar{7}$  is located between 5 and 6. In the next step, we locate  $5.3\bar{7}$  between 5.3 and 5.4. To get a more accurate visualisation of the representation, we divide this portion of the number line into ten equal parts and use a magnifying glass to visualize that  $5.3\bar{7}$  lies between 5.37 and 5.38. To visualize  $5.3\bar{7}$  more accurately, we again divide the portion between 5.37 and 5.38 in ten equal parts and use a magnifying glass to visualize that  $5.3\bar{7}$  lies 5.377 and 5.378. Now to visualize  $5.3\bar{7}$  still more accurately, we divide the portion between 5.377 and 5.378 into ten equal parts, and visualize the representation of  $5.3\bar{7}$  as in the fig. (iv) Notice that  $5.3\bar{7}$  is located closer to 5.3778 than to 5.3777 (iv)

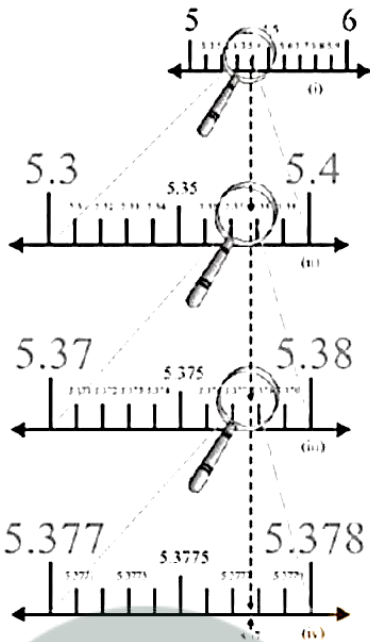

## CCE - Formative Assessment

### 1. Question

Which one of the following is a correct statement?

- A. Decimal expansion of a rational number is terminating.
- B. Decimal expansion of a rational number is non-terminating.
- C. Decimal expansion of an irrational number is terminating.
- D. Decimal expansion of an irrational number is non-terminating and non-repeating.

### Answer

D) The decimal expansion of an irrational number never repeats or terminates (essentially, that is repeating zeroes), unlike any rational number does.

### 2. Question

Which one of the following statements is true?

- A. The sum of two irrational numbers is always an irrational number.
- B. The sum of two irrational numbers is always a rational number.
- C. The sum of two irrational numbers may be a rational number or an irrational number.
- D. The sum of two irrational numbers is always an integer.

### Answer

If the irrational parts on adding forms a rational term then the whole number will be the irrational parts on adding gives again an irrational term then the complete number will be irrational.

### 3. Question

Which of the following is a correct statement?

- A. Sum of two irrational numbers is always irrational.
- B. Sum of a rational and irrational number is always an irrational number
- C. Square of an irrational number is always a rational number
- D. Sum of two rational numbers can never be an integer.

### Answer

Let the rational number be of the form  $\frac{p}{a}$ , where  $p \in \mathbb{Z}$ , while the rational number be  $r$ . If  $r + \frac{p}{a}$  is a rational then we have that,

$r + \frac{p}{a} = \frac{a}{b}$  for some  $a \in \mathbb{Z}$  and  $b \in \mathbb{Z} \setminus \{0\}$ . This means that  $r = \frac{a}{b} - \frac{p}{a} = \frac{aq - bp}{ba}$  where  $aq - bp \in \mathbb{Z}$  and this contradicts the facts that  $r$  is irrational. Hence, our assumption that  $r + \frac{p}{a}$  is a rational is false. Hence, it is an irrational number.

### 4. Question

Which of the following statement is true?

- A. Product of two irrational numbers is always irrational.
- B. Product of a rational and an irrational number is always irrational.
- C. Sum of two irrational numbers can never be irrational.
- D. Sum of an integer and a rational number can never be an integer.

### Answer

Example: Take any rational number other than Zero let's take 2 as rational number and  $\sqrt{2}$  as irrational number than product as:

$$= 2 \times \sqrt{2} = 2\sqrt{2}$$

$2\sqrt{2}$  is irrational number so if we can say that if rational number other than zero product with any irrational number the result is also irrational.

### 5. Question

Which of the following is irrational?

- A.  $\sqrt{\frac{4}{9}}$
- B.  $\frac{4}{5}$

C.  $\sqrt{7}$

D.  $\sqrt{81}$

**Answer**

Proof: let us assume that  $\sqrt{7}$  be rational.

then it must in the form of  $p / q$  [ $q \neq 0$ ] [ $p$  and  $q$  are co-prime]

$$\sqrt{7} = p / q$$

$$\sqrt{7} \times q = p$$

squaring on both sides

$$7q^2 = p^2 \text{ (i)}$$

$p^2$  is divisible by 7

$p$  is divisible by 7

$p = 7c$  [ $c$  is a positive integer] [squaring on both sides ]

$$p^2 = 49 c^2 \text{ (ii)}$$

Substitute  $p^2$  in eq (i), we get,

$$7q^2 = 49 c^2$$

$$q^2 = 7c^2$$

$q$  is divisible by 7

Thus  $q$  and  $p$  have a common factor 7.

There is a contradiction

As our assumption  $p$  &  $q$  are co - prime but it has a common factor.

So that  $\sqrt{7}$  is an irrational.

**6. Question**

Which of the following is irrational?

A. 0.14

B.  $0.14\overline{16}$

C.  $0.\overline{1416}$

D. 0.1014001400014....

**Answer**

Since, it is non - terminating and non - repeating decimal.

**7. Question**



Which of the following is rational?

- A.  $\sqrt{3}$
- B.  $\pi$
- C.  $\frac{4}{0}$
- D.  $\frac{0}{4}$

**Answer**

Since it is in the form of  $p/q$ , and where  $q \neq 0$ .

**8. Question**

The number 0.318564318564318564..... is:

- A. A natural number
- B. An integer
- C. A rational number
- D. An irrational number

**Answer**

Since it is a non-terminating repeating decimal, hence it is a rational number.

**9. Question**

In  $n$  is a natural number, then  $\sqrt{n}$  is

- A. Always a natural number
- B. Always an irrational number
- C. Always an irrational number
- D. Sometimes a natural number and sometimes an irrational number

**Answer**

If  $n$  can be written in the form of  $p/q$ , where  $q \neq 0$ , then it is a rational number else irrational.

**10. Question**

Which of the following numbers can be represented as non-terminating, repeating decimals?

- A.  $\frac{39}{24}$
- B.  $\frac{3}{16}$
- C.  $\frac{3}{11}$

D.  $\frac{137}{25}$

**Answer**

Since, it can be represented as 0.27272727... which is a non - terminating repeating decimal.

**11. Question**

Every point on a number line represents

- A. A unique real number
- B. A natural number
- C. A rational number
- D. An irrational number

**Answer**

A real number is a value that represents a quantity along a line.

**12. Question**

An irrational number between 2 and 2.5 is

- A.  $\sqrt{11}$
- B.  $\sqrt{5}$
- C.  $\sqrt{22.5}$
- D.  $\sqrt{12.5}$

**Answer**

**Note:** If  $a$  and  $b$  are two positive numbers, such that the product of  $a$  and  $b$  is not a perfect square of a rational number, then,  $\sqrt{ab}$  is an irrational number lying between "a" and "b".

So, now we have two numbers 2 and 2.5.

Now the product of these two number is 5, which is not a perfect square. So, we can say that  $\sqrt{5}$  is an irrational number lying between "2" and "2.5"

$\sqrt{5} = 2.23606797749978969$ , Which is a non-terminating and non-repeating decimal.

Thus, option B is the correct answer.

**13. Question**

Which of the following is irrational?

- A. 0.15
- B. 0.01516
- C.  $0.\overline{1516}$
- D. 0.5015001500015...



**Answer**

Since, it is non - terminating and non - repeating decimal.

**14. Question**

The number of consecutive zeroes in  $2^3 \times 3^4 \times 5^4 \times 7$ , is

- A. 3
- B. 2
- C. 4
- D. 5

**Answer**

3As the expression has  $2^3 \times 5^3$  which yields zeroes in expression.as this would make 1000 so 3 zeroes will be there

**15. Question**

The number  $1.\overline{27}$  in the form  $\frac{p}{q}$ , where  $p$  and  $q$  are integers and  $q \neq 0$ , is

- A.  $\frac{14}{9}$
- B.  $\frac{14}{11}$
- C.  $\frac{14}{13}$
- D.  $\frac{14}{15}$

**Answer**

Since, after dividing 14 from 11, we get that number.

**16. Question**

The number  $0.\overline{3}$  in the form  $\frac{p}{q}$ , where  $p$  and  $q$  are integers and  $q \neq 0$ , is

- A.  $\frac{33}{100}$
- B.  $\frac{3}{10}$
- C.  $\frac{1}{3}$
- D.  $\frac{3}{100}$

**Answer**



Since, among the following only the division of 1 by 3 gives that specified number.

**17. Question**

The smallest rational number by which  $\frac{1}{3}$  should be multiplied so that its decimal expansion terminates after one place of decimal, is

- A.  $\frac{1}{10}$
- B.  $\frac{3}{10}$
- C. 3
- D. 30

**Answer**

Since, among them  $\frac{3}{10}$  is the only number which when multiplied, then its decimal expansion terminates after one place of decimal.

**18. Question**

$0.3\bar{2}$  when expressed in the form  $\frac{p}{q}$  ( $p, q$  are integers,  $q \neq 0$ ), is

- A.  $\frac{8}{25}$
- B.  $\frac{29}{90}$
- C.  $\frac{32}{99}$
- D.  $\frac{32}{199}$

**Answer**

Let  $x = 0.3\bar{2}$

$10x = 3.\bar{2}$  (i)

$100x = 32.\bar{2}$  (ii)

Now, subtracting (i) from (ii), we get

$100x - 10x = 32.\bar{2} - 3.\bar{2}$

$90x = 29$

$x = \frac{29}{90}$

**19. Question**

$23.\bar{43}$  when expressed in the form  $\frac{p}{q}$  ( $p, q$  are integers,  $q \neq 0$ ), is

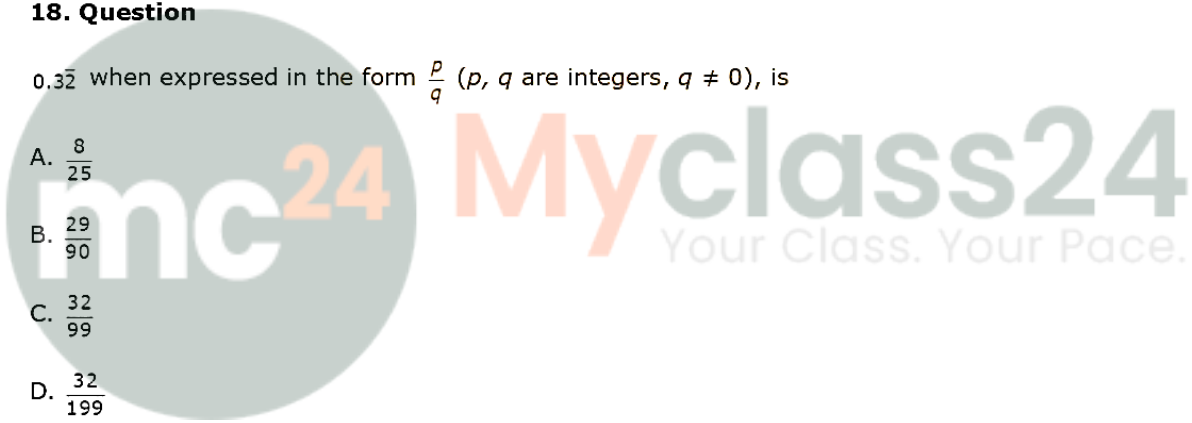

A.  $\frac{2320}{99}$

B.  $\frac{2343}{100}$

C.  $\frac{2343}{999}$

D.  $\frac{2320}{199}$

**Answer**

$$x = 23.\overline{43} \quad (i)$$

$$100x = 2343.\overline{43} \quad (ii)$$

Subtracting (i) from (ii), we get

$$100x - x = 2343.\overline{43} - 23.\overline{43}$$

$$99x = 2320$$

$$x = \frac{2320}{99}$$

**20. Question**

$0.\overline{001}$  when expressed in the form  $\frac{p}{q}$  ( $p, q$  are integers,  $q \neq 0$ ), is

A.  $\frac{1}{1000}$

B.  $\frac{1}{100}$

C.  $\frac{1}{1999}$

D.  $\frac{1}{999}$

**Answer**

$$x = 0.\overline{001} \quad (i)$$

$$1000x = 001.\overline{001} \quad (ii)$$

Subtracting (i) from (ii), we get

$$1000x - x = 001.\overline{001} - 0.\overline{001}$$

$$999x = 1$$

$$x = \frac{1}{999}$$

**21. Question**

The value of  $0.\overline{23}+0.\overline{22}$  is

A.  $0.\overline{45}$

B.  $0.\overline{43}$

C.  $0.\overline{45}$

D. 0.45

**Answer**

$$0.\overline{23} = 0.232323\dots$$

$$0.\overline{22} = 0.222222\dots$$

$$\text{Now, } 0.\overline{23}+0.\overline{22} = 0.23232323\dots + 0.22222222\dots$$

$$= 0.45454545\dots$$

$$= 0.\overline{45}$$



**Myclass24**  
Your Class. Your Pace.