

## EXERCISE 12.4

A solid metallic hemisphere of radius 8 cm is melted and recasted into a right circular cone of base radius 6 cm. Determine the height of the cone.

**Solution:**

For hemisphere,

Radius,  $r = 8$  cm

We know that,

Volume of hemisphere =  $\frac{2}{3} \pi r^3$ , where,  $r =$  radius of hemisphere

So, we get,

Volume of given hemisphere =  $\frac{2}{3} \times \pi \times 8^3 = \frac{1024}{3} \pi \text{ cm}^3$

Now,

For the cone that is recast from a hemisphere,

Base radius,  $r = 6$  cm

We also know that,

Volume of cone =  $\frac{1}{3} \pi r^2 h$ , where,  $r$  is base radius and  $h$  is the height of the cone.

So, we get,

Volume of cone =  $\frac{1}{3} \pi (6)^2 h = 12\pi h$

According to the question, we know that,

The volume remains same, when a body is reformed to another body

Volume of cylinder = Volume of cone

$12\pi h = 1024\pi / 3$

$h = 28.44$  cm

1. A rectangular water tank of base  $11 \text{ m} \times 6 \text{ m}$  contains water upto a height of 5 m. If the water in the tank is transferred to a cylindrical tank of radius 3.5 m, find the height of the water level in the tank.

**Solution:**

Volume of water in tank = volume of cuboidal tank up to a height of 5 m

According to the question,

For cuboidal tank

Length,  $l = 11$  m

Breadth,  $b = 6$  m

Height,  $h = 5$  m

We know that the equation to find the volume of the tank,

Volume of tank =  $lbh$ , where,  $l$ ,  $b$  and  $h$  are the length, breadth and height of tank respectively

Volume of water =  $11(6)(5) = 330 \text{ m}^3$

We also know that,

Base radius of cylindrical tank,  $r = 3.5$  m

Let the height till which the cylindrical tank is filled =  $h$  m

Hence, using the formula,

Volume of a cylinder =  $\pi r^2 h$ , where  $r$  is base radius and  $h$  is the height of cylinder

Volume of water in cylindrical tank =  $\pi (3.5)^2 h$

$330 \text{ m}^3 = \frac{22}{7} \times 3.5 \times 3.5 \times h = 38.5 \times$

$h = 8.57$  m

Hence, the height till which the cylindrical tank is filled = 8.57 m

2. How many cubic centimetres of iron is required to construct an open box whose external dimensions are 36 cm, 25 cm and 16.5 cm provided the thickness of the iron is 1.5 cm. If one cubic cm of iron weighs 7.5 g, find the weight of the box.

## Class 10 Maths Chapter 12-Surface Areas And Volumes

### Solution:

Let the length ( $l$ ), breadth ( $b$ ), and height ( $h$ ) be the external dimension of an open box and thickness be  $x$ .

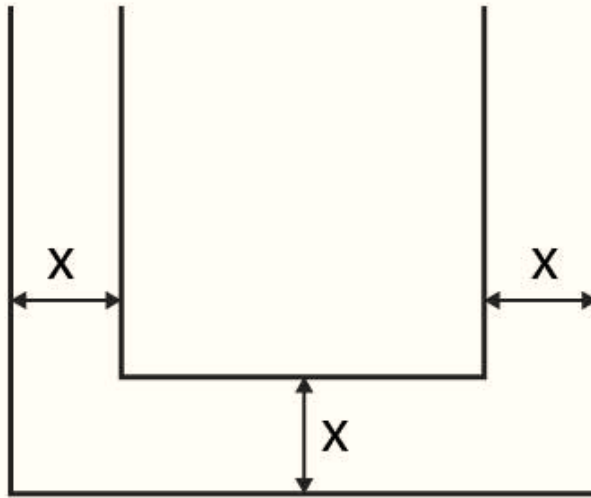

The volume of metal used in box = Volume of external box - Volume of internal box

Consider external box,

Length,  $l = 36$  cm

Breadth,  $b = 25$  cm

Height,  $h = 16.5$  cm

We know that the equation of the volume of cuboid is given by,

Volume of cuboid =  $lbh$ , where,  $l$ ,  $b$  and  $h$  are the length, breadth and height of tank respectively

Volume of external box =  $36(25)(16.5) = 14850$  cm<sup>3</sup>

Since the box is open from top,

Consider internal box,

The thickness of two sides is reduced as follows,

Length,  $l' =$  Length of external box -  $2(\text{thickness of box}) = 36 - 2(1.5) = 33$  cm

Breadth,  $b' =$  Breadth of external box -  $2(\text{thickness of box}) = 25 - 2(1.5) = 22$  cm

Height,  $h' =$  Height of external box - thickness of box =  $16.5 - 1.5 = 15$  cm

Volume of internal box =  $33(22)(15) = 10890$

And,

Volume of metal in box =  $14850 - 10890 = 3960$  cm<sup>3</sup>

We know that,

1 cm<sup>3</sup> weighs 7.5 g

So, 3960 cm<sup>3</sup> weighs  $3960(7.5) = 29,700$  g

Therefore, the weight of box is 29,700 g i.e. 29.7 kg

**3. The barrel of a fountain pen, cylindrical in shape, is 7 cm long and 5 mm in diameter. A full barrel of ink in the pen is used up on writing 3300 words on an average. How many words can be written in a bottle of ink containing one fifth of a litre?**

### Solution:

Let us first calculate the volume of barrel of pen that is of cylindrical shape

Consider barrel,

Since 1 cm = 10 mm

## Class 10 Maths Chapter 12-Surface Areas And Volumes

Base diameter = 5 mm = 0.5 cm

Base radius,  $r = 0.25$  cm

Height,  $h = 7$  cm

We know that,

Volume of a cylinder =  $\pi r^2 h$

Volume of barrel =  $\pi (0.25)^2 7$

Volume of barrel =  $22/7 \times 0.25 \times 0.25 \times 7 = 1.375 \text{ cm}^3$

Hence, according to the question,

$1.375 \text{ cm}^3$  of ink can write 3300 words

No of words that can be written by  $1 \text{ cm}^3$  of ink =  $3300/1.375 = 2400$  words

$1/5^{\text{th}}$  of a liter = 0.2 L

We know that,

1 L =  $1000 \text{ cm}^3$

0.2 L =  $200 \text{ cm}^3$

So, no of words that can be written by  $200 \text{ cm}^3 = 2400(200) = 480000$  words

Therefore,  $1/5^{\text{th}}$  of a liter ink can write 480000 words.

**4. Water flows at the rate of 10m/minute through a cylindrical pipe 5 mm in diameter. How long would it take to fill a conical vessel whose diameter at the base is 40 cm and depth 24 cm?**

**Solution:**

Let the time taken by pipe to fill vessel =  $t$  minutes

Since water flows 10 m in 1 minute, it will flow  $10t$  meters in  $t$  minutes.

According to the question,

Volume of conical vessel = Volume of water that passes through pipe in  $t$  minutes

Consider conical pipe

Base Diameter = 40 cm

Base radius,  $r = 20$  cm

Height,  $h = 24$  cm

We know that the volume of cone =  $1/3\pi r^2 h$

Volume of conical vessel =  $1/3\pi(20)^2(24) = 3200 \pi \text{ cm}^3$

Consider cylindrical pipe

Base diameter = 5 mm = 0.5 cm

Base radius,  $r = 0.25$  cm

Water covers  $10t$  m distance in pipe,

Hence, we get,

Height,  $h = 10t$  m =  $1000t$  cm

We also know that,

Volume of a cylinder =  $\pi r^2 h$

Volume of water passed in pipe =  $\pi(0.25)^2(1000t) = 62.5t\pi \text{ cm}^3$

So, we have

$$62.5t\pi = 3200$$

$$62.5t = 3200$$

$$t = 51.2 \text{ minutes}$$

We know that,

$$0.2 \text{ minutes} = 0.2(60) \text{ seconds} = 12 \text{ seconds}$$

Therefore,  $t = 51$  minutes 12 seconds

**5. A heap of rice is in the form of a cone of diameter 9 m and height 3.5 m. Find the volume of the rice. How much canvas cloth is required to just cover the heap?**

**Solution:**

## Class 10 Maths Chapter 12-Surface Areas And Volumes

According to the question,  
Consider conical heap,  
Base Diameter = 9 cm  
So, base radius,  $r = 4.5$  cm  
Height,  $h = 3.5$  cm  
We know that,  
Slant height,

$$l = \sqrt{r^2 + h^2}$$
$$\Rightarrow \sqrt{(4.5)^2 + (3.5)^2} = \sqrt{20.25 + 12.25}$$
$$\Rightarrow l = \sqrt{32.5} = 5.7 \text{ cm}$$

The equation of volume of cone =  $\frac{1}{3}\pi r^2 h$   
We know that,

Volume of rice = Volume of conical heap  
Volume of rice =  $\frac{1}{3}\pi(4.5)^2(3.5)$

$$\Rightarrow \text{Volume of rice} = \frac{1}{3} \times \frac{22}{7} \times 4.5 \times 4.5 \times 3.5 = 74.25 \text{ cm}^3$$

We also know that,

Canvas requires to just cover heap = Curved surface area of conical heap

And curved surface area of a cone =  $\pi r l$

Therefore, the canvas required =  $\pi(4.5)(5.7) = 80.61 \text{ cm}^2$  [appx]

**6. A factory manufactures 120000 pencils daily. The pencils are cylindrical in shape each of length 25 cm and circumference of base as 1.5 cm. Determine the cost of colouring the curved surfaces of the pencils manufactured in one day at Rs 0.05 per  $\text{dm}^2$ .**

**Solution:**

The shape of pencil = cylinder.

Let the radius of base =  $r$  cm

Circumference of base = 1.5 cm

Circumference of circle is  $2\pi r = 1.5$  cm

$$r = 1.5/2\pi \text{ cm}$$

According to the question,

Height,  $h = 25$  cm

We know that,

Curved surface area of cylinder =  $2\pi r h$

$$\text{Curved surface area of pencil} = 2\pi (1.5/2\pi) 25 = 37.5 \text{ cm}^2$$

$$1 \text{ cm} = 0.1 \text{ dm}$$

$$1 \text{ cm}^2 = 0.01 \text{ dm}^2$$

$$37.5 \text{ cm}^2 = 0.375 \text{ dm}^2$$

Cost for coloring 1  $\text{dm}^2 = \text{Rs. } 0.05$

Cost for coloring 0.375  $\text{dm}^2$  (i.e. 1 pencil) = Rs. 0.01875

Cost for coloring 120000 pencils =  $120000 \times 0.01875 = \text{Rs. } 2250$

**7. Water is flowing at the rate of 15 km/h through a pipe of diameter 14 cm into a cuboidal pond which is 50 m long and 44 m wide. In what time will the level of water in pond rise by 21 cm?**

**Solution:**

## Class 10 Maths Chapter 12-Surface Areas And Volumes

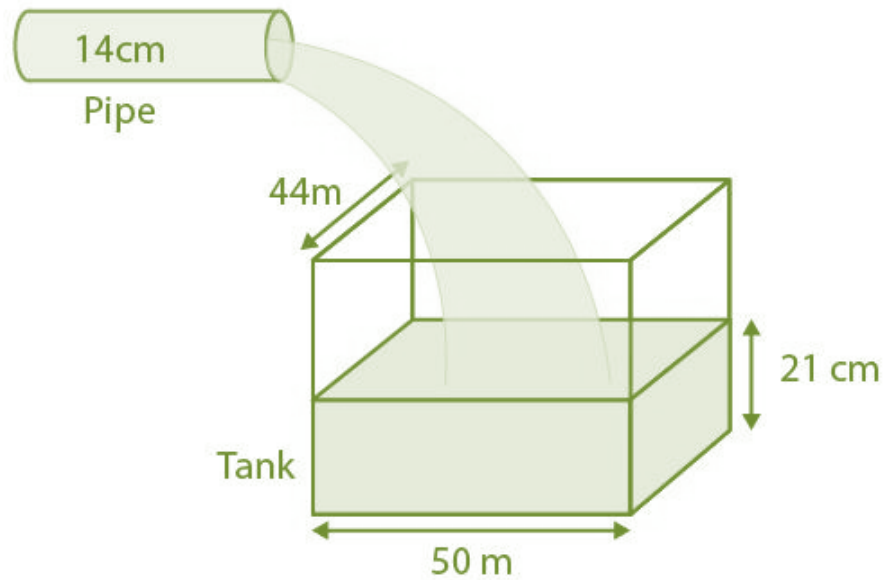

Let the time taken by pipe to fill pond =  $t$  hours

Water flows 15 km in 1 hour, so, it will flow  $15t$  meters in  $t$  hours.

We know that,

Volume of cuboidal pond up to height 21 cm = Volume of water that passes through pipe in “ $t$ ” hours

Considering cuboidal pond,

Length,  $l = 50$  m

Breadth,  $b = 44$  m

Height,  $h = 21$  cm = 0.21 m

We know that,

Volume of tank =  $lbh$

Volume of water =  $50(44)(0.21) = 462$  m<sup>3</sup>

Considering cylindrical pipe

Base diameter = 14 cm

Base radius,  $r = 7$  cm = 0.07 m

Height,  $h = 15t$  km =  $15000t$  m

We also know that,

Volume of a cylinder =  $\pi r^2 h$

Volume of water passed in pipe =  $\pi(0.07)^2(15000t)$

$= \frac{22}{7} \times 0.07 \times 0.07 \times 15000t$

$= 231t$  cm<sup>3</sup>

So, we have

$231t = 462$

$t = 2$  hours

Time required to fill tank up to a height of 25 cm is 2 hours.

**8. A solid iron cuboidal block of dimensions  $4.4$  m  $\times$   $2.6$  m  $\times$   $1$  m is recast into a hollow cylindrical pipe of internal radius 30 cm and thickness 5 cm. Find the length of the pipe.**

**Solution:**

Considering cuboidal block

Length,  $l = 4$  m

Breadth,  $b = 2.6$  m

## Class 10 Maths Chapter 12-Surface Areas And Volumes

Height,  $h = 1$  m

We know that,

Volume of tank =  $lbh$

$$\text{Volume of cuboid} = 4.4(2.6)(1) = 11.44 \text{ m}^3$$

We know that,

The volume remains same when a body is recast to another body.

According to the question,

$$\text{Volume of cylindrical pipe} = 11.44 \text{ m}^3$$

Considering pipe or the hollow cylinder

Internal radius,  $r_2 = 30$  cm =  $0.3$  m

Thickness =  $5$  cm

External radius,  $r_1 =$  Internal radius + thickness =  $30 + 5 = 35$  cm =  $0.35$  m

Let the length of pipe =  $h$

We know that,

$$\text{Volume of a hollow cylinder} = \pi h(r_1^2 - r_2^2)$$

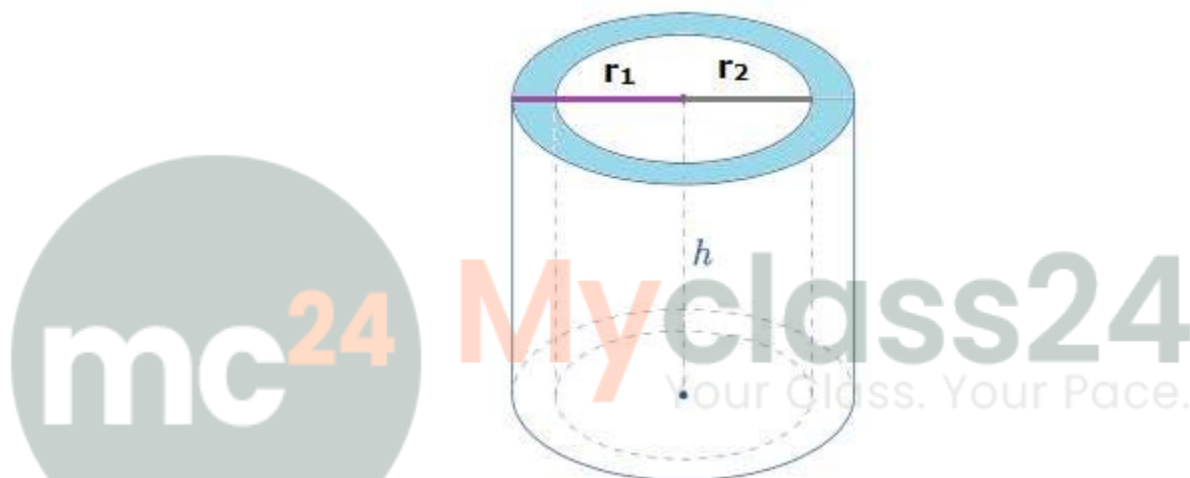

Hence,

$$\text{Volume of pipe} = \pi h((0.35)^2 - (0.3)^2)$$

$$\Rightarrow 11.44 = \frac{22}{7} \times h \times 0.0325$$

$$\Rightarrow h = \frac{11.44 \times 7}{22 \times 0.0325} = 112 \text{ m}$$

So, the length of pipe is  $112$  m.

**9. 500 persons are taking a dip into a cuboidal pond which is  $80$  m long and  $50$  m broad. What is the rise of water level in the pond, if the average displacement of the water by a person is  $0.04 \text{ m}^3$ ?**

**Solution:**

According to the question,

Average displacement by a person =  $0.04 \text{ m}^3$

Average displacement by  $500$  persons =  $500 \times 0.04 = 20 \text{ m}^3$

Hence, the volume of water raised in pond =  $20 \text{ m}^3$

## Class 10 Maths Chapter 12-Surface Areas And Volumes

---

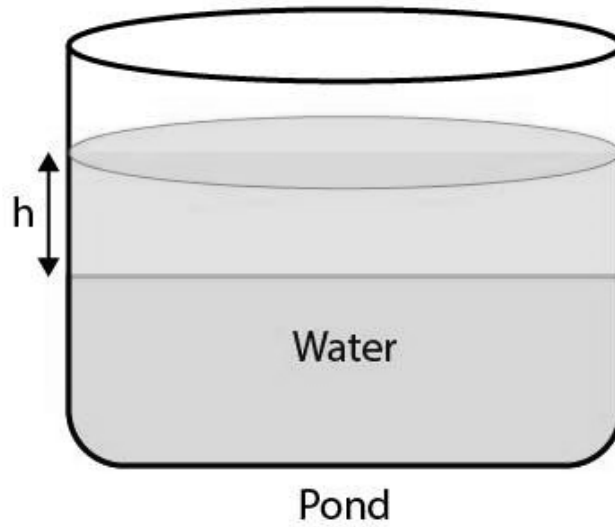

It is also given that,

Length of pond,  $l = 80$  m

Breadth of pond,  $b = 50$  m

Height =  $h$

Volume of water raised in pond =  $80(50)(h)$

$20 \text{ m}^3 = 4000h$

$h = 0.005 \text{ m} = 0.5 \text{ cm}$

Therefore, raise in the height of water =  $0.5 \text{ cm}$ .