

EXERCISE 14C

1. Using ruler and compasses, construct the following angles:

(i) 30°

(ii) 15°

(iii) 75°

(iv) 180°

(v) 165°

Solution:

(i) 30°

Steps of Construction:

1. Construct a line segment BC.
2. Taking B as centre and a suitable radius construct an arc which meets BC at the point P.
3. Taking P as centre and same radius cut off the arc at the point Q.
4. Consider P and Q as centre construct two arcs which intersect each other at the point R.
5. Now join BR and produce it to point A forming $\angle ABC = 30^\circ$

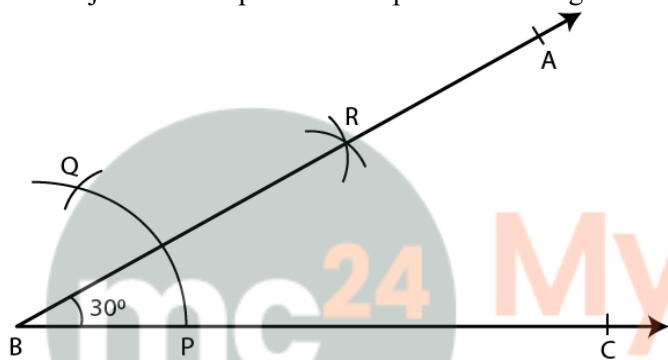

(ii) 15°

Steps of Construction:

1. Construct a line segment BC.
2. Taking B as centre and a suitable radius construct an arc which meets BC at the point P.
3. Taking P as centre and same radius cut off the arc at the point Q.
4. Consider P and Q as curves, construct two arcs which intersect each other at the point D and join BD.
5. Taking P and R as centre construct two more arcs which intersect each other at the point S.
6. Now join BS and produce it to point A.

$\angle ABC = 15^\circ$

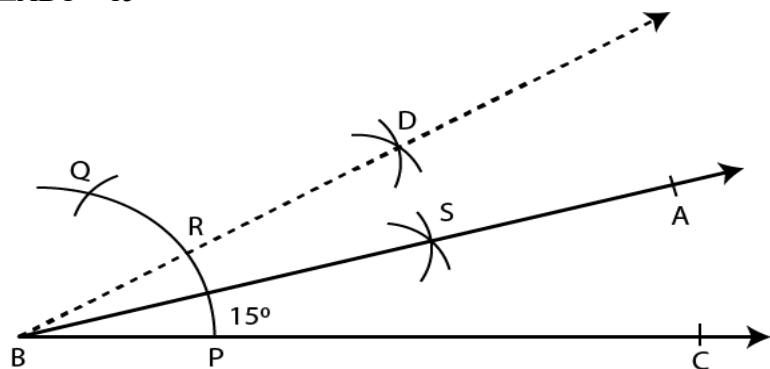

(iii) 75°

**Selina Solutions Concise Maths Class 7 Chapter 14 –
Lines and Angles (Including Construction of Angles)**

Steps of Construction:

1. Construct a line segment BC.
2. Taking B as centre and suitable radius construct an arc and cut off PQ then QR of the same radius.
3. Taking Q and R as centre, construct two arcs which intersect each other at the point S.
4. Now join SB.
5. Taking Q and D as centre construct two arcs which intersect each other at the point T.
6. Now join BT and produce it to point A.

$\angle ABC = 75^\circ$

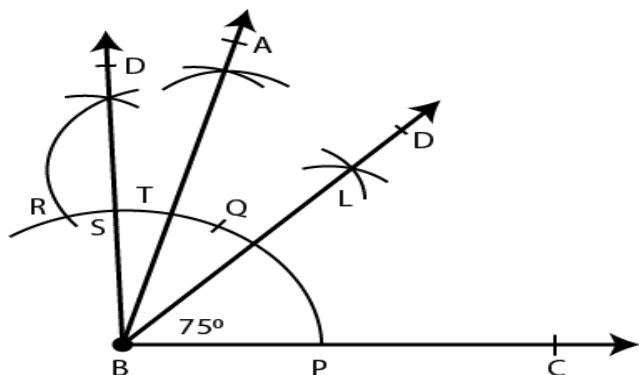

(iv) 180°

Steps of Construction:

1. Construct a line segment BC.
2. Taking B as centre and some suitable radius construct an arc which meets BC at the point P.
3. Taking P as centre and with same radius cut off the arcs PQ, QR and RS.
4. Now join BS and produce it to point A.

$\angle ABC = 180^\circ$

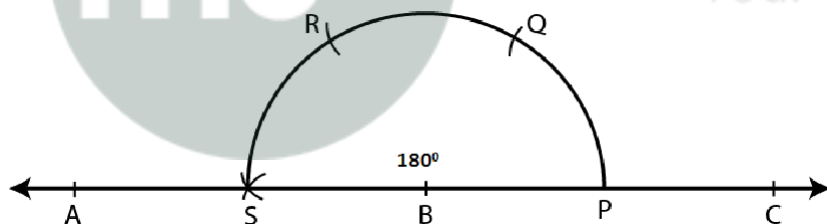

(v) 165°

Steps of Construction:

1. Construct a line segment BC.
2. Taking B as centre and some suitable radius construct an arc which meets BC at the point P.
3. Taking P as centre and same radius cut off arcs at PQ, QR and then RS.
4. Now join SB.
5. Taking R and S as centres construct two arcs which intersect each other at the point M.
6. Taking T and S as centres construct two arcs which intersect each other at the point L.
7. Now join BL and produce it to point A.

$\angle ABC = 165^\circ$

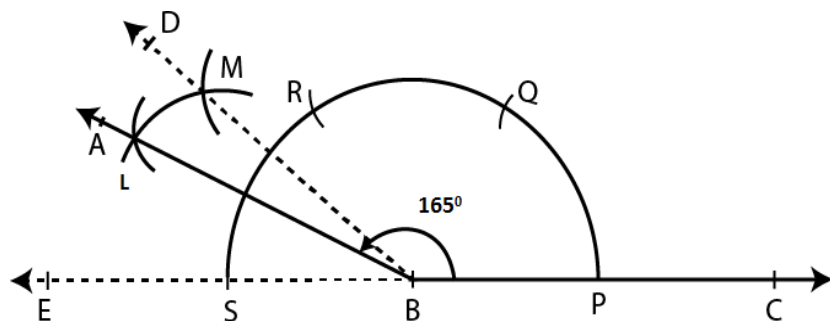

2. Draw $\angle ABC = 120^\circ$. Bisect the angle using ruler and compasses only. Measure each angle so obtained and check whether the angles obtained on bisecting $\angle ABC$ are equal or not.

Solution:

Steps of Construction:

1. Construct a line segment BC.
2. Taking B as centre and some suitable radius construct an arc which meets BC at the point P.
3. Taking P as centre and with same radius cut off the arcs PQ and QR.
4. Now join BR and produce it to point A
 $\angle ABC = 120^\circ$
5. Taking P and R as centres construct two arcs which intersect each other at the point S.
6. Now join BS and produce it to point D.

Here BD is the bisector of $\angle ABC$

By measuring each angle we get to know that it is 60°

Yes, both the angles are of equal measure.

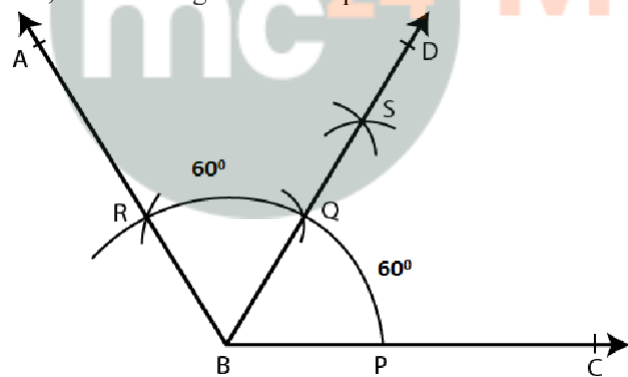

3. Draw a line segment $PQ = 6$ cm. Mark a point A in PQ so that $AP = 2$ cm. At point A, construct angle $QAR = 60^\circ$.

Solution:

Steps of Construction:

1. Construct a line segment $PQ = 6$ cm.
2. Now mark point A on PQ so that $AP = 2$ cm.
3. Taking A as centre and some suitable radius construct an arc which meets AQ at the point C.
4. Taking C as centre and with same radius cut the arc CB.
5. Now join AB and produce it to point R.
 $\angle QAR = 60^\circ$.

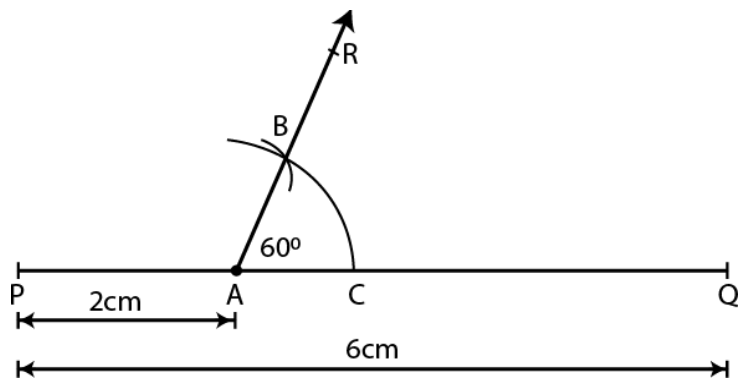

4. Draw a line segment $AB = 8$ cm. Mark a point P in AB so that $AP = 5$ cm. At P , construct angle $APQ = 30^\circ$.

Solution:

Steps of Construction:

1. Construct a line segment $AB = 8$ cm.
2. Now mark the point P on AB such that $AP = 5$ cm.
3. Taking P as centre and some suitable radius construct an arc which meets AB in L .
4. Taking L as centre and same radius cut the arc LM .
5. Now bisect the arc LM at the point N .
6. Join PN and produce it to point Q .

$\angle APQ = 30^\circ$

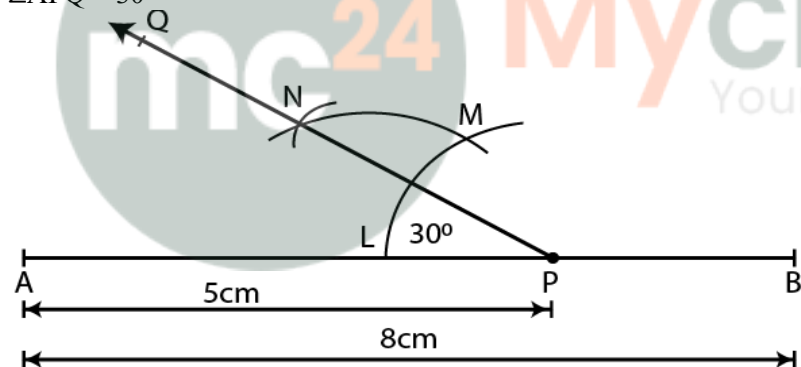

5. Construct an angle of 75° and then bisect it.

Solution:

Steps of Construction:

1. Construct a line segment BC .
2. At the point B construct an angle ABC which is equal to 75° .
3. Taking P and T as centres construct arcs which intersect each other at the point L .
4. Now join BL and produce it to point D .

Here BD bisects $\angle ABC$.

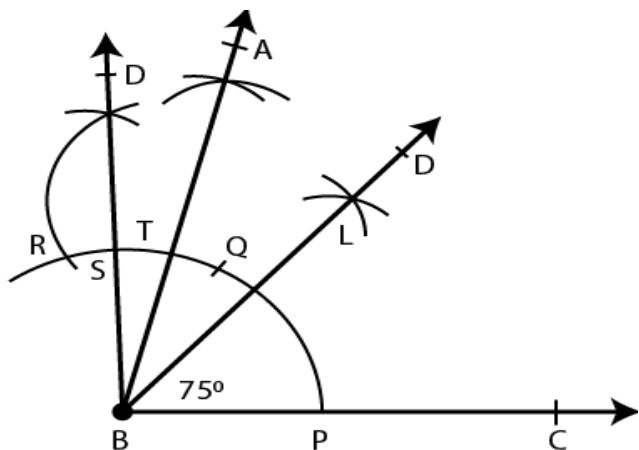

6. Draw a line segment of length 6.4 cm. Draw its perpendicular bisector.

Solution:

Steps of Construction:

1. Construct a line segment $AB = 6.4$ cm.
 2. Taking A and B as centres and with some suitable radius construct arcs which intersect each other at the points S and R.
 3. Now join SR which intersects AB at the point Q.
- Here PQR is the perpendicular bisector of the line segment AB.

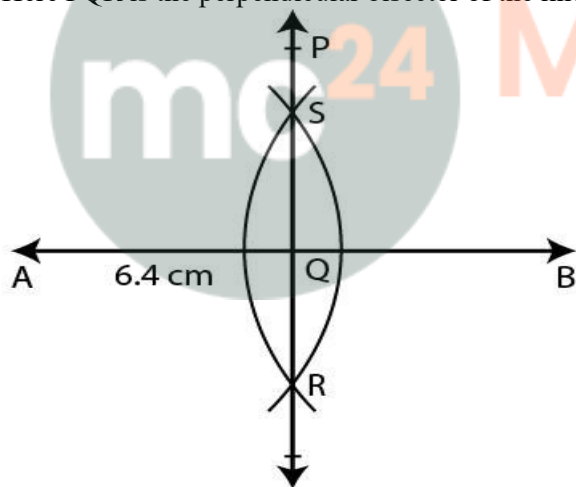

7. Draw a line segment $AB = 5.8$ cm. Mark a point P in AB such that $PB = 3.6$ cm. At P, draw perpendicular to AB.

Solution:

Steps of Construction:

1. Construct a line segment $AB = 5.8$ cm.
2. Now mark a point P on the line segment AB such that $PB = 3.6$ cm.
3. Taking P as centre and some suitable radius construct an arc which meets AB at the point L.
4. Taking L as centre and same radius cut off the arcs LM and then as N.
5. Now bisect the arc MN at the point S.
6. Join PS and produce it to point Q.

Here PQ is perpendicular to the line segment AB at point P.

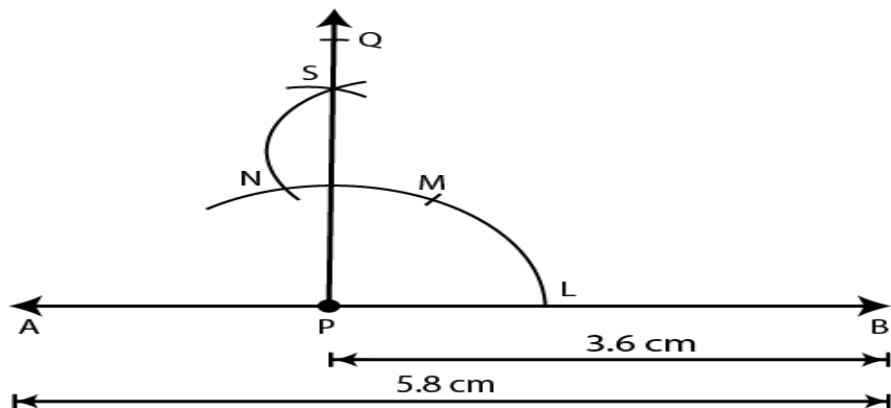

8. In each case, given below, draw a line through point P and parallel to AB:

(i)

P •



(ii)

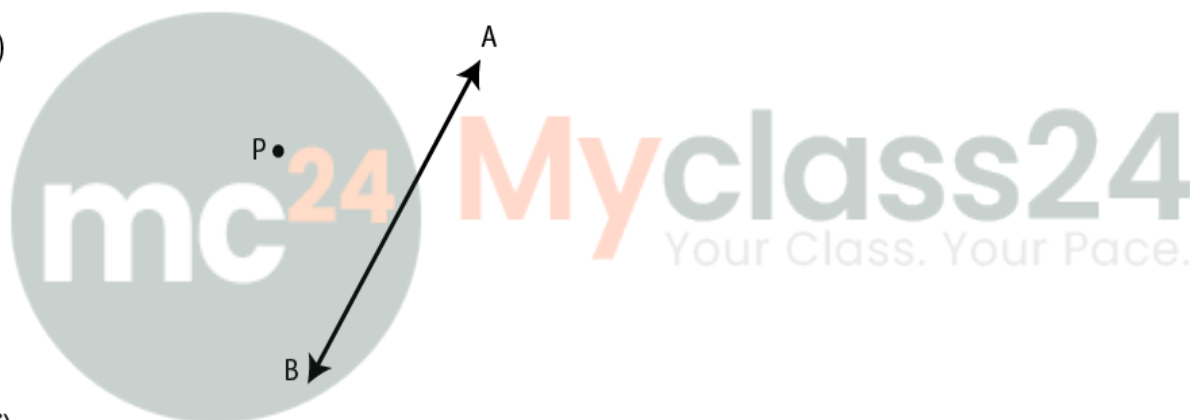

(iii)



•P

Solution:

Steps of Construction:

1. From the point P construct a line segment meeting AB
2. Taking Q as centre and some suitable radius construct an arc CD.
3. Taking P as centre and same radius construct another arc which meets PQ at the point E.

Selina Solutions Concise Maths Class 7 Chapter 14 –
Lines and Angles (Including Construction of Angles)

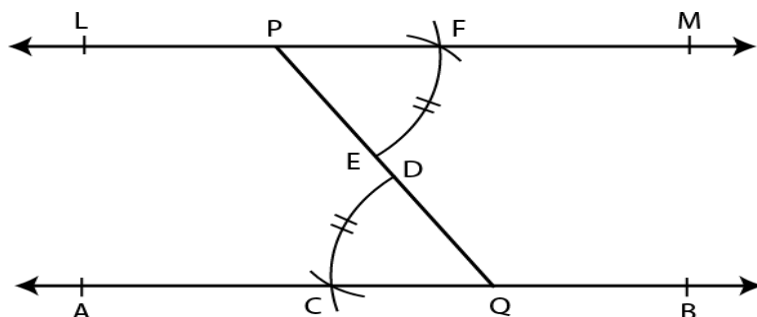

4. Taking E as centre and radius equal to CD cut this arc at the point F.

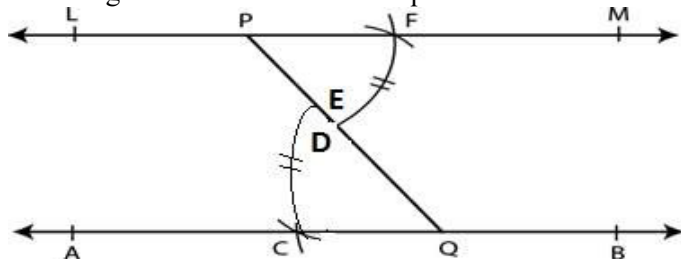

5. Now join PF and produce it to both sides to L and M.
Here the line LM is parallel to the given line AB.

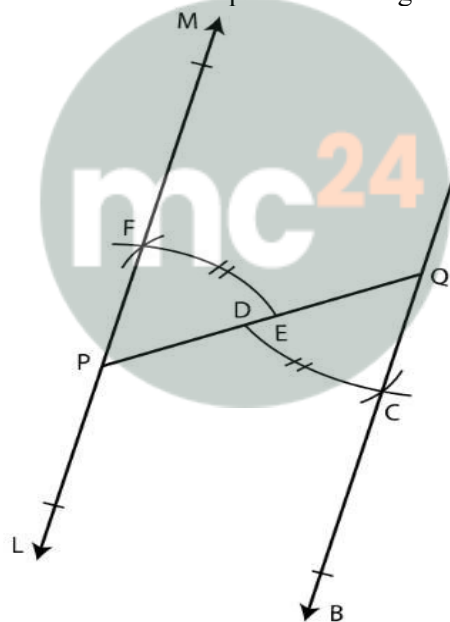

Myclass24
Your Class. Your Pace.