

Multiple Choice Questions I

8.1. One requires 11eV of energy to dissociate a carbon monoxide molecule into carbon and oxygen atoms. The minimum frequency of the appropriate electromagnetic radiation to achieve the dissociation lies in

- a) visible region
- b) infrared region
- c) ultraviolet region
- d) microwave region

Answer:

- c) ultraviolet region

$$E = E_0 \hat{i} \cos(kz - \omega t)$$

8.2. A linearly polarized electromagnetic wave given as $E = E_0 \hat{i} \cos(kz - \omega t)$ is incident normally on a perfectly reflecting infinite wall at $z = a$. Assuming that the material of the wall is optically inactive, the reflected wave will be given as

a)

$$E_r = -E_0 \hat{i} \cos(kz - \omega t)$$

b)

$$E_r = E_0 \hat{i} \cos(kz + \omega t)$$

c)

$$E_r = -E_0 \hat{i} \cos(kz + \omega t)$$

d)

$$E_r = E_0 \hat{i} \sin(kz - \omega t)$$

Answer:

b)

$$E_r = E_0 \hat{i} \cos(kz + \omega t)$$

8.3. Light with an energy flux of 20 W/cm² falls on a non-reflecting surface at normal incidence. If the surface has an area of 30cm², the total momentum delivered during 30 minutes is

- a) 36×10^{-5} kg m/s
- b) 36×10^{-4} kg m/s
- c) 108×10^4 kg m/s
- d) 1.08×10^7 kg m/s

Answer:

- b) 36×10^{-4} kg m/s

8.4. The electric field intensity produced by the radiations coming from 100 W bulb at a 3 m distance is E. The electric field intensity produced by the radiations coming from 50 W bulb at the same distance is

- a) E/2
- b) 2E
- c) E/ $\sqrt{2}$

d) $\sqrt{2}E$

Answer:

c) $E/\sqrt{2}$

8.5. If E and B represent electric and magnetic field vectors of the electromagnetic wave, the direction of propagation of electromagnetic wave is along

a) E

b) B

c) $B \times E$

d) $E \times B$

Answer:

d) $E \times B$

8.6. The ratio of contributions made by the electric field and magnetic field components to the intensity of an EM wave is

a) $c : 1$

b) $c^2 : 1$

c) $1 : 1$

d) $\sqrt{c} : 1$

Answer:

c) $1 : 1$

8.7. An EM wave radiates outwards from a dipole antenna, with E_0 as the amplitude of its electric field vector. The electric field E_0 which transports significant energy from the source falls off as

a) $1/r^3$

b) $1/r^2$

c) $1/r$

d) remains constant

Answer:

c) $1/r$

Multiple Choice Questions II

8.8. An electromagnetic wave travels in vacuum along z-direction:

$$E = (E_1\hat{i} + E_2\hat{j})\cos(kz - \omega t)$$

. Choose the correct options from the following:

$$B = \frac{1}{c}(E_1\hat{i} - E_2\hat{j})\cos(kz - \omega t)$$

a) the associated magnetic field is given as

$$B = \frac{1}{c}(E_1\hat{i} + E_2\hat{j})\cos(kz - \omega t)$$

b) the associated magnetic field is given as

c) the given electromagnetic field is circularly polarised

d) the given electromagnetic waves is plane polarised

Answer:

$$B = \frac{1}{c}(E_1 \hat{i} - E_2 \hat{j}) \cos(kz - \omega t)$$

- a) the associated magnetic field is given as
 d) the given electromagnetic waves is plane polarised

8.9. An electromagnetic wave travelling along z-axis is given as: $E = E_0 \cos(kz - \omega t)$. Choose the correct options from the following

$$B = \frac{1}{c} \hat{k} \times E = \frac{1}{\omega} (\hat{k} \times E)$$

- a) the associated magnetic field is given as
 b) the electromagnetic field can be written in terms of the associated magnetic field as

$$E = c(B \times \hat{k})$$

$$\hat{k} \cdot E = 0, \hat{k} \cdot B = 0$$

c)

$$\hat{k} \times E = 0, \hat{k} \times B = 0$$

d)

Answer:

$$B = \frac{1}{c} \hat{k} \times E = \frac{1}{\omega} (\hat{k} \times E)$$

- a) the associated magnetic field is given as

$$E = c(B \times \hat{k})$$

- b) the electromagnetic field can be written in terms of the associated magnetic field as

$$\hat{k} \cdot E = 0, \hat{k} \cdot B = 0$$

c)

8.10. A plane electromagnetic wave propagating along x direction can have the following pairs of E and B

- a) E_x, B_y
 b) E_y, B_z
 c) B_x, E_y
 d) E_z, B_y

Answer:

- b) E_y, B_z
 d) E_z, B_y

8.11. A charged particle oscillates about its mean equilibrium position with a frequency of 109 Hz. The electromagnetic waves produced:

- a) will have frequency of 10^9 Hz
 b) will have frequency of 2×10^9 Hz
 c) will have a wavelength of 0.3 m
 d) fall in the region of radiowaves

Answer:

- a) will have frequency of 10^9 Hz
- c) will have a wavelength of 0.3 m
- d) fall in the region of radiowaves

8.12. The source of electromagnetic waves can be a charge

- a) moving with a constant velocity
- b) moving in a circular orbit
- c) at rest
- d) falling in an electric field

Answer:

- b) moving in a circular orbit
- d) falling in an electric field

8.13. An EM wave of intensity I falls on a surface kept in vacuum and exerts radiation pressure p on it. Which of the following are true?

- a) radiation pressure is I/c if the wave is totally absorbed
- b) radiation pressure is I/c if the wave is totally reflected
- c) radiation pressure is $2I/c$ if the wave is totally reflected
- d) radiation pressure is in the range $I/c < p < 2I/c$ for real surface

Answer:

- a) radiation pressure is I/c if the wave is totally absorbed
- c) radiation pressure is $2I/c$ if the wave is totally reflected
- d) radiation pressure is in the range $I/c < p < 2I/c$ for real surface

Very Short Answers

8.14. Why is the orientation of the portable radio with respect to broadcasting station important?

Answer:

The orientation of the portable radio with respect to broadcasting station is important because the electromagnetic waves are plane polarised and the antenna should be placed parallel to the vibration of the electric or magnetic field of the wave.

8.15. Why does microwave oven heats up a food item containing water molecules most efficiently?

Answer:

The microwave oven heats up a food item containing water molecule most efficiently because the frequency of the microwave and the resonant frequency of the water molecules are the same.

8.16. The charge on a parallel plate capacitor varies as $q = q_0 \cos 2\pi vt$. The plates are very large and close together. Neglecting the edge effects, find the displacement current through the capacitor?

Answer:

The displacement current through the capacitor is $I_d = I_c = dq/dt$

Given, $q = q_0 \cos 2\pi vt$

Substituting the values, we get

$$I_d = I_c = -2\pi v q_0 \sin 2\pi vt$$

8.17. A variable frequency a.c source is connected to a capacitor. How will the displacement current change with decrease in frequency?

Answer:

Capacitive reaction $X_c = 1/2\pi fc$

As there is decrease in frequency, X_c increases and the conduction current becomes inversely proportional to X_c .

8.18. The magnetic field of a beam emerging from a filter facing a floodlight is given by $B_0 = 12 \times 10^{-8} \sin(1.20 \times 10^7 z - 3.60 \times 10^{15} t)$ T. What is the average intensity of the beam?

Answer:

$$B_0 = 12 \times 10^{-8} \sin(1.20 \times 10^7 z - 3.60 \times 10^{15} t) \text{ T}$$

$$B_0 = 12 \times 10^{-8} \text{ T}$$

$$I_{av} = 1.71 \text{ W/m}^2$$

8.19. Poynting vectors S is defined as a vector whose magnitude is equal to the wave intensity and whose direction is along the direction of wave propagation. Mathematically, it is given by $S = 1/\mu_0 E \times B$. Show that nature of S versus t graph.

Answer:

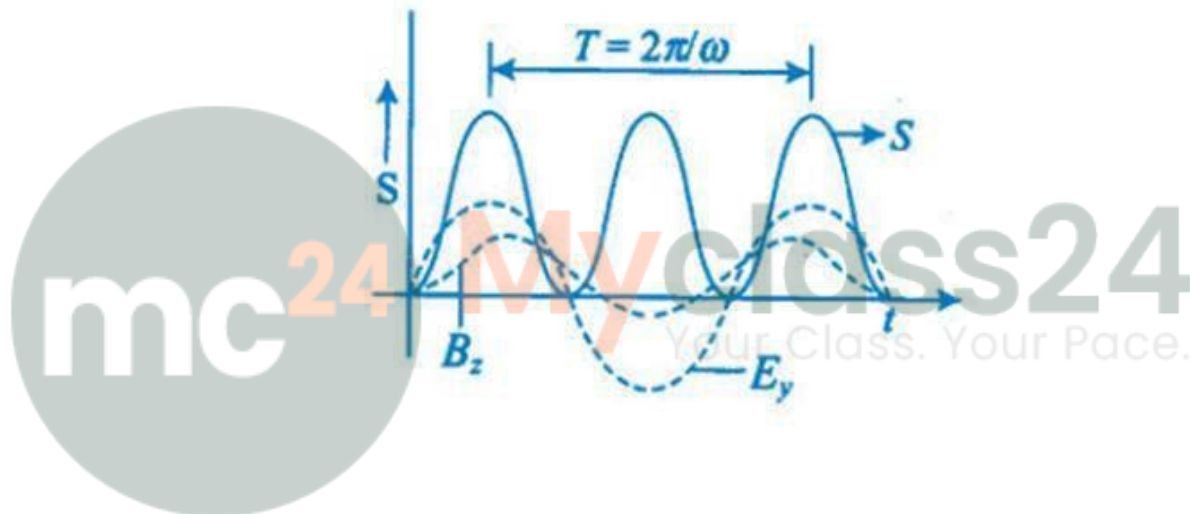

8.20. Professor C.V.Raman surprised his students by suspending freely a tiny light ball in a transparent vacuum chamber by shining a laser beam on it. Which property of EM waves was he exhibiting? Give one more example of this property.

Answer:

The radiation pressure property of EM waves was exhibited by Professor CV Raman.

Short Answers

8.21. Show that the magnetic field B at a point in between the plates of a parallel-plate capacitor during charging is $\epsilon_0 \mu_r / 2 dE/dt$.

Answer:

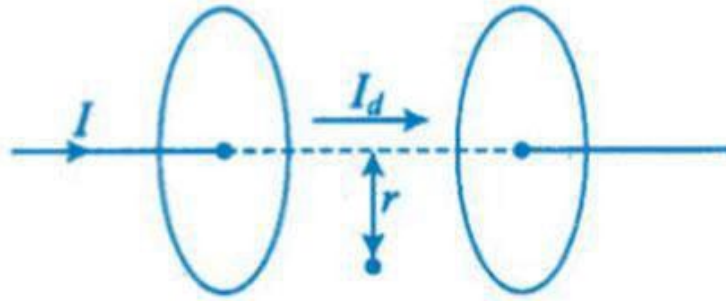

Id is the displacement current between the two plates of parallel plate capacitor.

The distance between the two plates is r

This is given as

$$B = \mu_0 \epsilon_r / 2 \, dE/dt$$

8.22. Electromagnetic waves with wavelength

i) λ_1 is used in satellite communication

ii) λ_2 is used to kill germs in water purifiers

iii) λ_3 is used to detect leakage of oil in underground pipelines

iv) λ_4 is used to improve visibility in runways during fog and mist conditions

a) identify and name the part of electromagnetic spectrum to which these radiations belong

b) arrange these wavelengths in ascending order of their magnitude

c) write one more application of each

Answer:

a)

i) λ_1 is microwave which is used in satellite communication.

ii) λ_2 is UV rays which is used in water purifier for killing germs.

iii) λ_3 is X-rays which is used in improving the visibility.

b) $\lambda_3 < \lambda_2 < \lambda_4 < \lambda_1$

c) Gamma rays are used in nuclear structures

X rays are used in medical diagnosis

UV rays are used in preservation of food

Visible light is used to see objects

Infrared rays are used to take photography

Microwave and radio waves are used in telecommunication

8.23. Show that average value of radiant flux density S over a single period T is given by $S = 1/2c\mu_0 E_0^2$.

Answer:

Radiant flux density is given as

$$\vec{S} = \frac{1}{\mu_0} (\vec{E} \times \vec{B}) = c^2 \epsilon_0 (\vec{E} \times \vec{B})$$

$$E = E_0 \cos(kx - \omega t)$$

$$B = B_0 \cos(kx - \omega t)$$

$$EB = c^2 \epsilon_0 (E_0 B_0) \cos^2(kx - \omega t)$$

Average value of the radiant flux density is

$$S_{av} = E_0^2 / 2\mu_0 c$$

8.24. You are given a 2 μ F parallel plate capacitor. How would you establish an instantaneous displacement current of 1 mA in the space between its plates?

Answer:

The capacitance of the capacitor $C = 2\mu\text{F}$

Displacement current $I_d = 1 \text{ mA}$

Charge in capacitor, $q = CV$

$$dV/dt = 500 \text{ V/s}$$

8.25. Show that the radiation pressure exerted by an EM wave of intensity I on a surface kept in vacuum is I/c .

Answer:

Energy received by the surface per second = $E = IA$

No. of photons received by the surface per second = N

The perfect absorbing is = h/λ

Pressure, $P = F/A = I/c$

8.26. What happens to the intensity of light from a bulb if the distance from the bulb is doubled? As a laser beam travels across the length of a room, its intensity essentially remains constant. What geometrical characteristics of LASER beam is responsible for the constant intensity which is missing in the case of light from the bulb?

Answer:

When the distance is doubled, the intensity of light becomes one-fourth.

Following are the geometrical characteristics of LASER:

- a) unidirectional
- b) monochromatic
- c) coherent light

8.27. Even though an electric field E exerts a force qE on a charged particle yet the electric field of an EM wave does not contribute to the radiation pressure. Explain.

Answer:

Even though an electric field E exerts a force qE on a charged particle yet the electric field of an EM wave does not contribute to the radiation pressure because radiation pressure is the result of action of magnetic field of the wave on the electric currents which is induced by the electric field.

Long Answers

8.28. An infinitely long thin wire carrying a uniform linear static charge density λ is placed along the z-axis. The wire is set into motion along its length with a uniform velocity $v = v\hat{k}_z$. Calculate the pointing vectors $S = 1/\mu_0 (\mathbf{E} \times \mathbf{B})$.

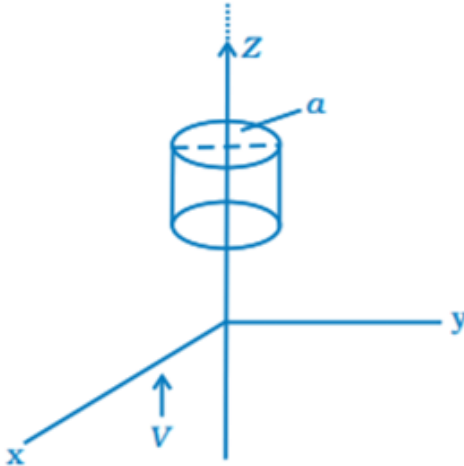

Answer:

The electric field in a infinitely long thin wire is

$$\vec{E} = \frac{\lambda \hat{e}_s}{2\pi\epsilon_0 a} \hat{j}$$

Magnetic field due to the wire is

$$\vec{B} = \frac{\mu_0 i}{2\pi a} \hat{i}$$

Equivalent current flowing through the wire is

$$\vec{S} = \frac{\lambda^2 v}{4\pi^2 \epsilon_0 a^2} \hat{k}$$

8.29. Sea water at frequency $\nu = 4 \text{ 108 Hz}$ has permittivity $\epsilon = 80 \epsilon_0$, permeability $\mu = \mu_0$ and resistivity $\rho = 0.25 \Omega\text{m}$. Imagine a parallel plate capacitor immersed in sea water and driven by an alternating voltage source $V(t) = V_0 \sin(2\pi\nu t)$. What fraction of the conduction current density is the displacement current density?

Answer:

The separation between the plates of capacitor is $V(t) = V_0 \sin(2\pi\nu t)$

Ohm's law for the conduction of current density $J_0^c = V_0/\rho d$

The displacement current density is $J_o^d = 2\pi v \epsilon V / d$

The fraction of the conduction of current density and the displacement density = $J_o^d / J_o^c = 4/9$

8.30. A long straight cable of length l is placed symmetrically along z -axis and has radius a . The cable consists of a thin wire and a co-axial conducting tube. An alternating current $I(t) = I_0 \sin(2\pi vt)$ flows down the central thin wire and returns along the co-axial conducting tube. The induced electric field at a distance

$$\left(\frac{s}{a}\right) \hat{k}$$

s from the wire inside the cable is $E(s,t) = \mu_0 I_0 v \cos(2\pi vt)$. In

- a) calculate the displacement current density inside the cable
- b) integrate the displacement current density across the cross-section of the cable to find the total displacement current I
- c) compare the conduction current I_0 with the displacement current I_0^d

Answer:

a) The displacement current density is given as

$$\vec{J}_d = \frac{2\pi I_0}{\lambda^2} \ln \frac{a}{s} \sin 2\pi vt \hat{k}$$

b) Total displacement current

$$I^d = \int J_d 2\pi s ds$$

Myclass24
Your Class. Your Pace.

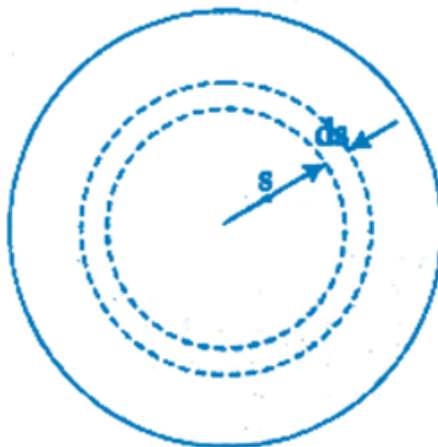

$$I_d = (\pi a / \lambda) 2 I_0 \sin 2\pi vt$$

c) The displacement current is $I_0^d / I_0 = (\pi a / \lambda)^2$

8.31. A plane EM wave travelling in vacuum along z direction is given by

$$E = E_0 \sin(kz - \omega t) \hat{i} \text{ and } B = B_0 \sin(kz - \omega t) \hat{j}$$

$$\oint E \cdot dl$$

a) evaluate over the rectangular loop 1234 shown in the figure

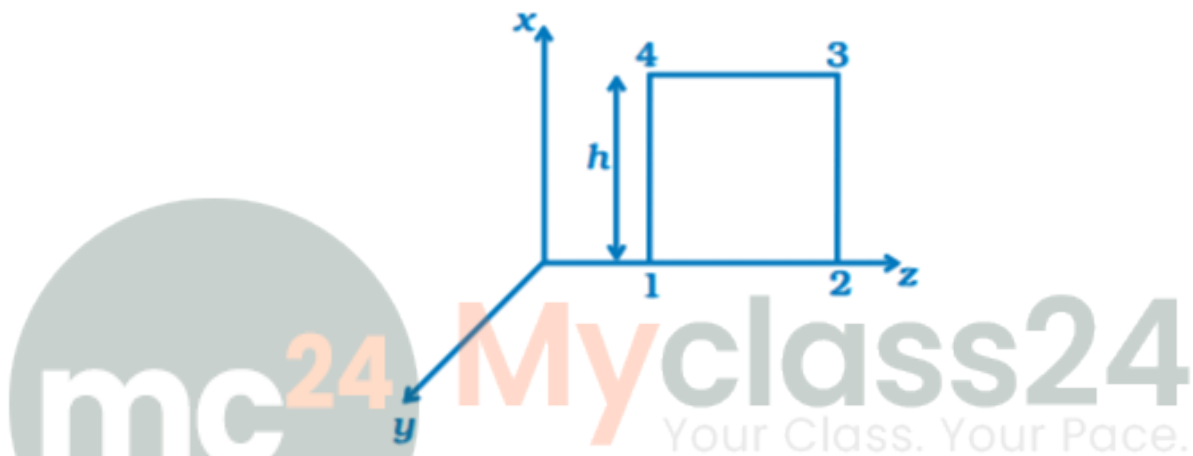

$$\int B \cdot ds$$

b) evaluate over the surface bounded by loop 1234

$$\oint E \cdot dl = \frac{-d\phi_B}{dt}$$

c) use equation to prove $E_0/B_0 = c$

$$\oint B \cdot dl = \mu_0 I \epsilon_0 \frac{-d\phi_E}{dt}$$

d) by using similar process and the equation , prove that

$$c = \frac{1}{\sqrt{\mu_0 \epsilon_0}}$$

Answer:

a)

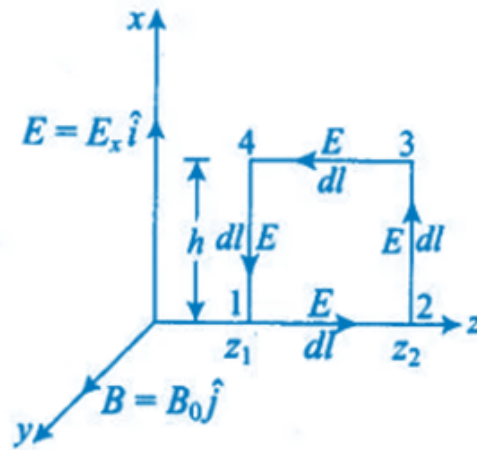

$$\oint \vec{E} \cdot \frac{d\vec{l}}{dl} = E_0 h [\sin(kz_2 - \omega t) - \sin(kz_1 - \omega t)]$$

b)

mc24 Myclass24
Your Class. Your Pace.

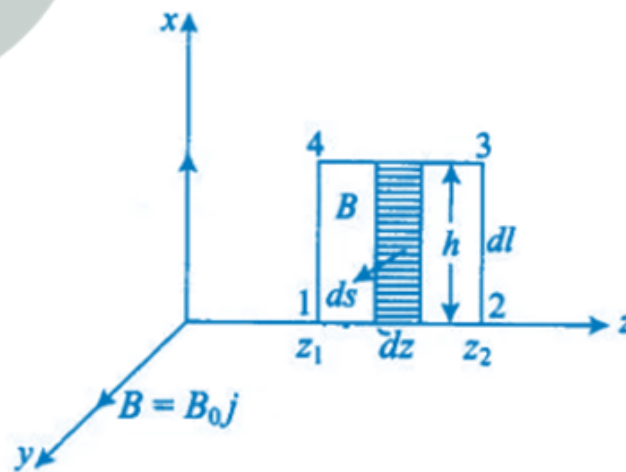

$$\int \vec{B} \cdot \frac{d\vec{s}}{ds} = -\frac{B_0 h}{k} [\cos(kz_2 - \omega t) - \cos(kz_1 - \omega t)]$$

c) Substituting the above equations in the following equation we get

$$\oint \vec{E} \cdot d\vec{l} = -\frac{d\phi_B}{dt} = -\frac{d}{dt} \oint \vec{B} \cdot d\vec{s}$$

$$E_0/B_0 = 0$$

d)

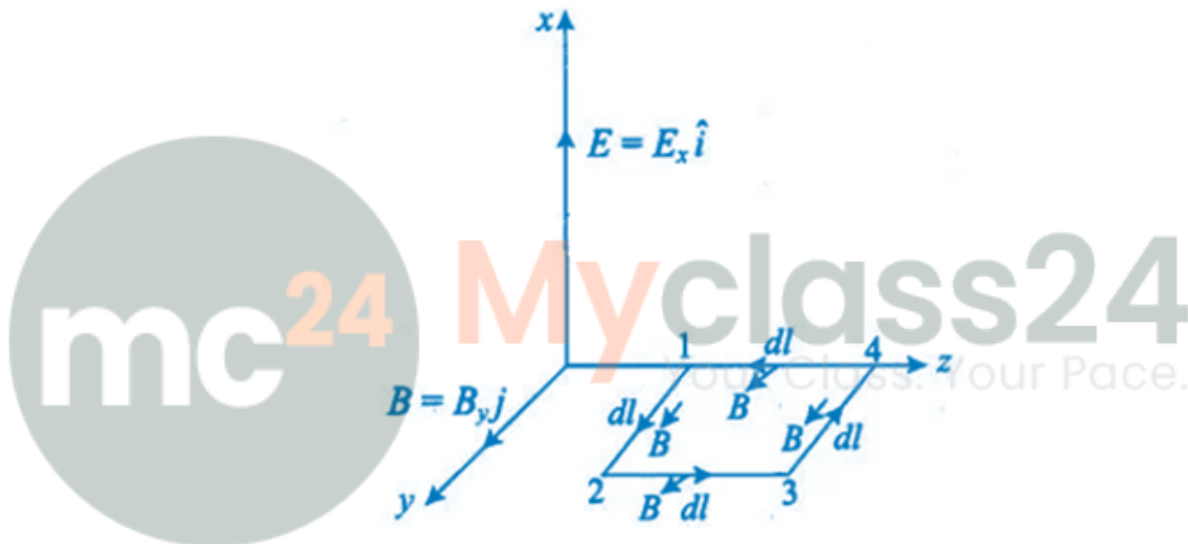

We get $c = 1/\sqrt{\mu_0 \epsilon_0}$

8.32. A plane EM wave traveling along z direction is described by

$$\vec{E} = E_0 \sin(kz - \omega t) \hat{i} \text{ and } \vec{B} = B_0 \sin(kz - \omega t) \hat{j}$$

Show that,

$$u_{av} = \frac{1}{4} \epsilon_0 E_0^2 + \frac{1}{4} \frac{B_0^2}{\mu_0}$$

i) the average energy density of the wave is given by

$$I_{av} = \frac{1}{2} c \epsilon_0 E_0^2$$

ii) the time averaged intensity of the wave is given by

Answer:

i) The energy density due to electric field E is

$$u_E = \frac{1}{2} \epsilon_0 E^2$$

The energy density due to magnetic field B is

$$u_B = \frac{1}{2} B^2 / \mu_0$$

The average energy density of the wave is given by:

$$u_{av} = \frac{1}{4} \epsilon_0 E_0^2 + \frac{1}{4} \frac{B_0^2}{\mu_0}$$

ii) We know that $c = 1/\sqrt{\mu_0 \epsilon_0}$

The time averaged intensity of the wave is given as

$$I_{av} = \frac{1}{2} c \epsilon_0 E_0^2$$



Myclass24
Your Class. Your Pace.