

EXERCISE 9(B)

Solution:

An electric fuse is defined as a safety device which is used to limit the current in an electric circuit. The use of a fuse safeguards the circuit and the appliances connected in that circuit from being damaged.

An alloy of lead and tin is used as the material of the fuse wire because its melting point is low and specific resistance is more than that of copper, aluminium, etc.

Solution:

The device used to protect the electric circuits from overloading and short circuit is fuse. It works on heating effect of current.

Question: 3

Complete the following sentences:

- (a) A fuse is a short piece of wire of high _____ and of material low _____.
- (b) A fuse wire is made of an alloy of _____ and _____. If the current in a circuit exceeds the current rating of the fuse wire it _____.
- (c) A fuse is connected in _____ with the _____ wire.
- (d) Higher the current rating, _____ is the fuse wire.
- (e) Live wire is also called _____ wire.

Solution:

- (a) A fuse is a short piece of wire of high resistance and of material low melting point.
- (b) A fuse wire is made of an alloy of lead and tin. If the current in a circuit exceeds the current rating of the fuse wire it melts.
- (c) A fuse is connected in series with the live wire.
- (d) Higher the current rating, thicker is the fuse wire.
- (e) Live wire is also called phase wire.

Question: 4

Why is the fuse wire fitted in a porcelain casing?

Solution:

Porcelain is an insulator of electricity. Hence, the fuse wire is fitted in a porcelain casing

Question: 5

How is a fuse put in an electric circuit? State the purpose of using a fuse in a circuit.

Solution:

Since porcelain is an insulator of electricity, hence the fuse wire is stretched between the two metallic terminals T_1 and T_2 in a porcelain holder. This holder fits into a porcelain socket having two metallic terminals to each of which the live wire of the circuit is connected. Thus the fuse wire gets connected in the live wire. The diagram below showing the fuse arrangement

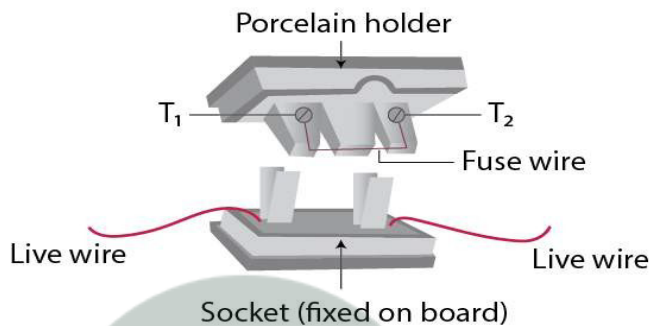

In order to safeguard the fuse from the flow of excessive current through it, a fuse is connected with each electrical appliance.

Question: 6

Describe with the aid of a diagram some form of a fuse, which is used in the electric lighting circuit of a house. Give two reasons why a fuse must not be replaced by an ordinary copper wire.

Solution:

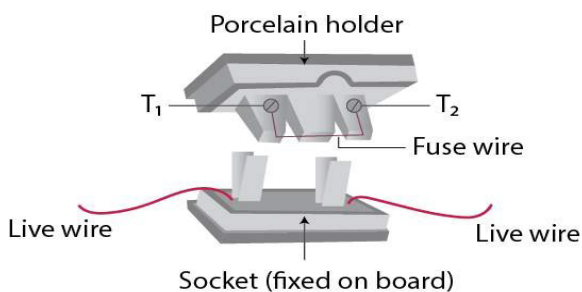

The most common fuse arrangement is shown in the above figure. In this fuse arrangement the fuse wire is stretched between the two metallic terminals T_1 and T_2 in a porcelain holder (since porcelain is an insulator of electricity). This holder fits into a porcelain socket having two metallic terminals to each of which the live wire of the circuit is connected.

Copper has very low resistivity and high melting point. Thus fuse must not be replaced with a copper wire.

Question: 7

A fuse is always connected in the live wire of the circuit. Explain the reason.

Solution:

If the fuse is put in the neutral wire, then due to some defect in the appliance an excessive current flows in the circuit, the fuse blows off and current stops flowing in the circuit, but the appliance remains connected to the high potential point of the supply through the live wire. Now if a person touches the faulty appliance, he gets an electric shock because the person comes in direct contact of the mains through the live wire. Therefore the fuse is always connected in the live wire of the circuit.

Question: 8

How does the (i) thickness and (ii) length of a fuse wire depend on its current rating?

Solution:

- (i) The current rating of the fuse wire is directly proportional to the thickness of the fuse wire. Higher the thickness of fuse wire, higher will be the current rating.
- (ii) The current rating of the fuse wire is independent on its length.

Question: 9

Two fuse wires are rated 5 A and 20 A. Which of the two is (i) thicker, (ii) longer?

Solution:

- (i) More the thickness of wire, more will be the current and thus more electrons can pass through a greater area. Therefore 20 A wire will be more thicker than the 5 A wire.
- (ii) Both fuse wires may be of same length.

Question: 10

Explain the meaning of the statement ‘the current rating of a fuse is 5 A’

Solution:

The current rating of a fuse is 5 A means that the fuse wire will melt if current exceeds 5 A in the circuit.

Question: 11

‘A fuse is rated 8 A’. Can it be used with an electrical appliance of rating 5 kW, 200 V?

Solution:

The safe limit of current which can flow through the electrical appliance is $I = P / V$

Now,

Substituting 5 kW and 200 V in $I = P / V$, we get

$$I = P / V$$

$$I = 5000 / 200$$

$$I = 25 \text{ A}$$

25 A is greater than 8 A.

Hence, such fuse cannot be used

Question: 12

An electrical kettle is rated 3 kW, 250 V. Give reason whether this kettle can be used in a circuit which contains a fuse of current rating 13 A.

Solution:

The safe limit of current for kettle is $I = 3000 / 250 = 12 \text{ A}$

Yes, this kettle can be used in a circuit which contains a fuse of current rating 13 A as the safe limit of current for kettle is 12 A.

Question: 13

(a) What is the purpose of a switch in a circuit?

(b) Why is the switch put in the live wire?

(c) What precaution do you take while handling a switch?

Solution:

A switch is an on-off device for current in a circuit (or in an appliance). It is connected in the live wire. The appliance gets connected to the high potential point through the live wire. The current flows in the appliance because the circuit is complete as the neutral wire provides the return path for the current. In the off position of the switch, the circuit is incomplete and no current reaches the appliance through the live wire.

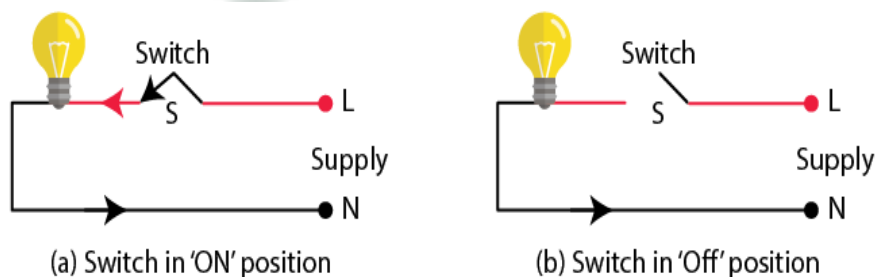

If switch is connected in the neutral wire, then in off position, no current passes through the bulb. But in the off position of switch, the appliance remains connected to the high potential terminal through the live wire.

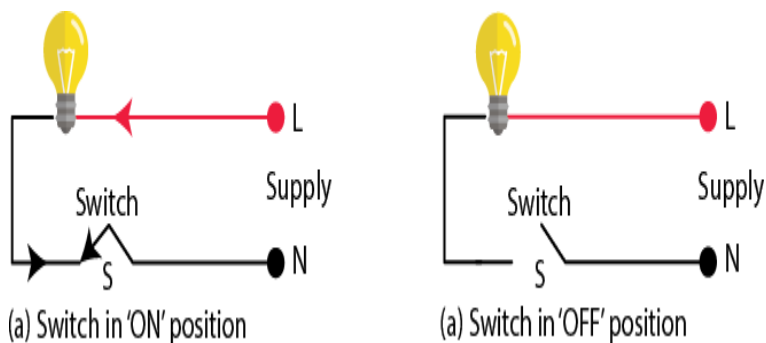

Therefore, it is deceptive and dangerous to connect a switch in the neutral wire. Safety precaution while using a switch: A switch should never be touched with wet hands.

Question: 14

(a) A switch is not touched with wet hands while putting it on or off. Give a reason for your answer.

(b) Name the wire to which a switch is connected.

Solution:

(a) If water reaches the live wire, it forms a conducting layer between the hand and the live wire of the switch due to which a current passes to the hand through it and the person may get a fatal shock. For this reason, the switch should never be touched with wet hands.

(b) The switch is connected to the live wire.

Question: 15

It is dangerous to connect the switch in the neutral wire. Explain your answer.

Solution:

It is dangerous to connect the switch in the neutral wire in case of excessive current. The fuse blows off due to excessive current and the current stops flowing in the circuit. But the appliance still remains connected to the high potential point of the supply through the live wire. Now, if the person touches the body of that appliance, he gets an electric shock. Thus it is highly unsafe to use fuse in the neutral wire.

Question: 16

Draw a circuit diagram using the dual control switches to light a staircase electric light and explain its working.

Solution:

Two switches S_1 and S_2 are used. Switch S_1 is fitted at the bottom and the switch S_2 at the top of the staircase. The off position of the bulb is shown in figure (a)

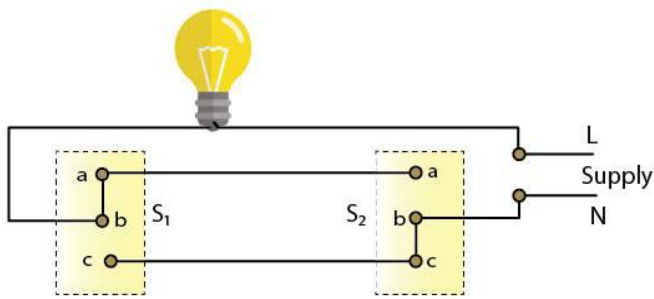

(a) Bulb off

The bulb can now be switched 'on' by either the switch S_1 or the switch S_2 independently. If the switch S_1 is operated, the connection 'ba' is changed to 'bc', which completes the circuit and the bulb lights up [as shown in figure (b) below]

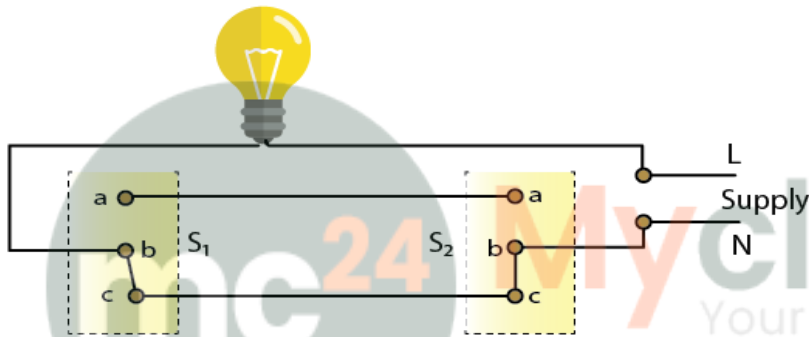

(b) Bulb on through switch S_1

Similarly, the connection 'bc' changes to 'ba' on operating the switch S_2 , which again completes the circuit [as shown in figure (c) below]

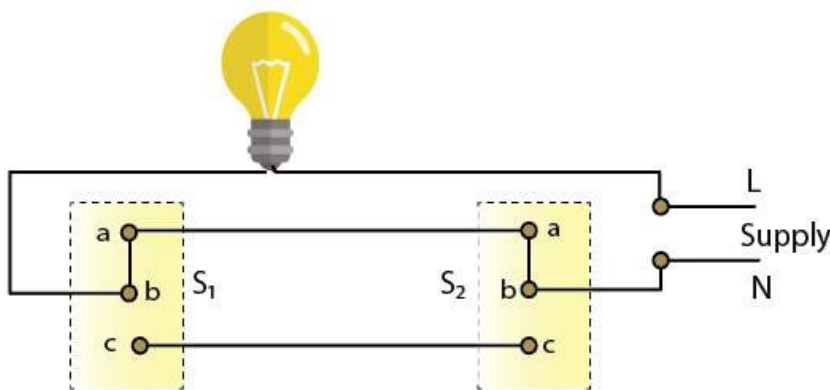

(c) Bulb on through switch S_2

Similarly, one can switch off the bulb either from the switch S_1 or the switch S_2 if the

bulb is in on position as shown in figure (b) or (c).

Question: 17

What purpose is served by the terminals of a three way pin plug? Draw a diagram and name the pins.

Solution:

To connect the appliance to the electric supply, all electrical appliances are provided with a cable having a plug at one end.

In this three pin plug, the top pin is for earthing, the pin on the left is for live and the pin on the right is for neutral. In the good quality plugs, these are marked as E, L and N respectively.

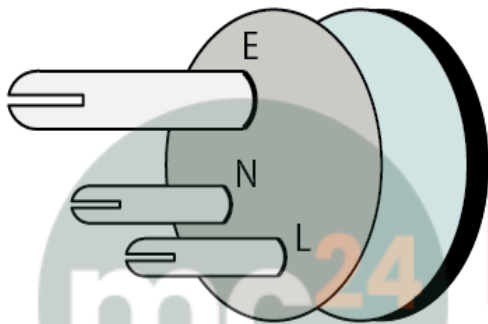

Question: 18

The diagram in fig. shows a three pin plug. Label the three pins.

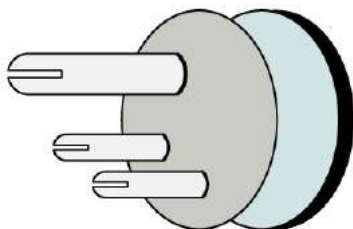

(a) Why is top pin thicker and longer than the other two?

(b) Why are the pins splitted at the ends?

Solution:

The three pins in the plug are labelled as E, L and N

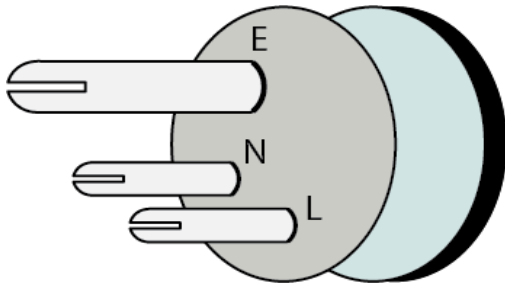

Here E signifies the earth pin,
L is for live wire and
N is for neutral wire

(a) The earth pin is made long so that the earth connection is made first. This ensures the safety of the user because if the appliance is defective, the current passes to the earth as soon as the live pin gets connected and the fuse blows off. The earth pin is made thicker because even by mistake it cannot be inserted into the hole of the live or neutral connection.

(b) The pins are splitted at the ends to provide a spring action so that they fit in the socket holes tightly.

Question: 19

Draw a labelled diagram of a three pin socket.

Solution:

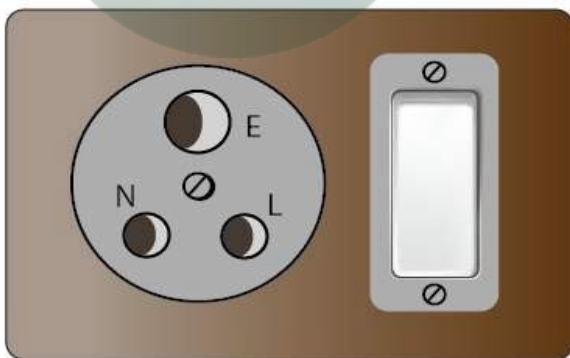

Here E is for earth pin, N for neutral wire pin and L for live wire pin

Question: 20

The diagram in Fig. shows a three-pin socket marked as 1, 2 and 3.

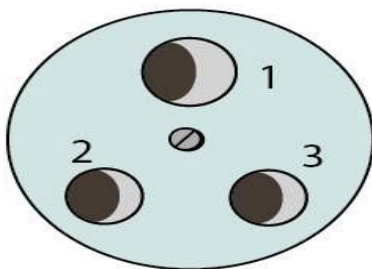

- (a) Identify and write live (L), neutral (N) and earth (E) against the correct number.
 (b) To which part of the appliance is the terminal 1 connected?
 (c) To which wire joined to 2 or 3, is the fuse connected?

Solution:

- (a) 1 – Earth, 2 – Neutral and 3 - Live
 (b) Terminal 1 is connected to the outer metallic case of the appliance
 (c) The fuse is connected to live wire joined to 3 because in case of excessive flow of current fuse melts first and breaks down the circuit to protect appliances.

Question: 21

What do you mean by the term local earthing? Explain how it is done.

Solution:

Local earthing is done in the house near the kWh meter. For this purpose, a hole nearly 2 – 3 metre deep is dug in the ground. A copper rod covered by a hollow insulating pipe, is inserted in the hole. A thick copper plate of dimensions 50 cm × 50 cm is welded at the lower end of the copper rod and it is buried inside the ground. The plate is surrounded by a mixture of charcoal and salt to make a good contact between the plate and the earth. Water is poured through the pipe from time to time to keep the ground damp. This forms a conducting layer between the plate and the ground. The upper end of the copper rod is joined to the earth connection at the kWh meter.

Question: 22

To which wire is the metallic case of an electric appliance connected? Give the reason?

Solution:

When the live wire of a faulty appliance comes in direct contact with its metallic case due to some reason then the appliance acquires the high potential of the live wire. A person touching the appliance will get a fatal shock because current flows through his body to the earth. But if the appliance is properly earthed, then as soon as the live wire comes in contact with the metallic case, a heavy current flows to the earth through the case of the appliance. The fuse connected in the circuit of appliance blows off. Hence, the appliance gets disconnected from the mains supply.

Question: 23

(a) The earthing of an electric appliance is useful only if the fuse is in the live wire.

Given the reason.

(b) Name the part of the appliance which is earthed.

Solution:

(a) If the fuse is in the neutral wire, then although the fuse burns due to the flow of heavy current, but the appliance remains at the supply voltage so that on touching the appliance current flows through the appliance to the person touching it. Hence, the fuse must be connected in the live wire only.

(b) The part of the appliance which is earthed is the metallic case.

Question: 24

For earthing an electrical appliance, one has to remove the paint from the metal body of the appliance where the electrical contact is made. Explain the reason.

Solution:

The paint provides an insulating layer on the metal body of the appliance. Therefore the paint must be removed from the body part where connection is to be made to make earth connection.

Question: 25

What is the colour code for the insulation on (a) live, (b) neutral and (c) earth wire?

Solution:

According to the new international convention

(a) Brown for live wire

(b) Light blue for neutral wire and

(c) Green or yellow for earth wire

Question: 26

Name the colour code of the wire which is connected to (i) metallic body of an appliance, (ii) switch for the appliance.

Solution:

(i) The colour code of the wire which is connected to metallic body of an appliance is the green colour i.e., earthing wire.

(ii) The colour code of the wire which is connected to switch of the appliance is red colour i.e., live wire.

Question: 27

How does the colour code of wires in a cable help in house wiring?

Solution:

The colour coding of wires in the circuit of house wiring helps us to connect the switch, fuse, sockets, etc. through proper wire.

Question: 28

A power circuit uses a cable having three different wires.

(a) Name the three wires of the cable.

(b) Between which of the two wires should the heating element of an electric geyser be connected?

(c) To which wire should the metal case of the geyser be connected?

(d) To which wire should the switch and fuse be connected?

Solution:

(a) The three wires of the cable are live wire, earth wire and neutral wire

(b) The heating element of an electric geyser should be connected between live wire and neutral wire

(c) The metal case of the geyser should be connected to earth wire

(d) The switch and fuse should be connected to live wire

Question: 29

State two circumstances when one may get an electric shock from an electric gadget. What preventive measures must be provided with the gadget to avoid it?

Solution:

An electric shock may be caused from an electrical gadget in the following cases

(i) If the fuse is put in neutral wire, due to some defect in the appliance an excessive current flows in the circuit, the fuse burns and the current stops flowing in the circuit. But the appliance still remains connected to the high potential point of the supply through the live wire. If a person touches the faulty appliance in this situation, he gets an electric shock because the person will come in contact of the mains through the live wire.

Preventive measure: The fuse must always be connected in the live wire.

(ii) When the live wire of a faulty appliance comes in direct contact with its metallic case due to break of insulation after its constant use, the appliance acquires the high potential of the live wire. A person touching the appliance will get a fatal shock because current flows through his body to the earth.

Preventive measure: Proper 'earthing' of the electric appliance should be done

Question: 30

Why is it necessary to have an earth wire installed in a power circuit, but not in a lighting circuit?

Solution:

It is necessary to have an earth wire installed in a power circuit because power circuit

carries high power and costly devices. It can damage the device if there is some unwanted power signal in the wire. To reduce this effect earth wire is necessary.

MULTIPLE CHOICE TYPE

Question: 1

The rating of a fuse connected in the lighting circuit is:

- (a) 15 A
- (b) 5 A
- (c) 10 A
- (d) Zero

Solution:

The rating of a fuse connected in the lighting circuit is 5 A

Question: 2

A switch must be connected in the:

- (a) live wire
- (b) neutral wire
- (c) earth wire
- (d) either earth or neutral wire

Solution:

A switch must be connected in the live wire