

Exercise 18.1

1. The length and breadth of a rectangular field are in the ratio 9 : 5. If the area of the field is 14580 square metres, find the cost of surrounding the field with a fence at the rate of ₹3.25 per metre.

Solution:

Let the length of rectangle be $9x$ and its breadth be $5x$

So,

$$\text{Area} = l \times b$$

$$\Rightarrow 14580 = 9x \times 5x$$

$$45x^2 = 14580$$

$$x^2 = 14580/45 = 324$$

$$x = \sqrt{324}$$

$$x = 18$$

Hence,

$$\text{Length} = 9 \times 18 = 162 \text{ m and Breadth} = 5 \times 18 = 90 \text{ m}$$

$$\text{Now, Perimeter} = 2(l + b)$$

$$= 2(162 + 90) = 2(252)$$

$$= 504 \text{ m.}$$

Therefore, cost for fencing the surrounding 504 m at the rate of ₹3.25 per metre = ₹(504 × 3.25) = ₹1638

2. A rectangle is 16 m by 9 m. Find a side of the square whose area equals the area of the rectangle. By how much does the perimeter of the rectangle exceed the perimeter of the square?

Solution:

$$\text{Area of rectangle} = (16 \times 9) \text{ m}^2 = 144 \text{ m}^2$$

Given condition,

$$\text{Area of square} = \text{Area of rectangle}$$

$$\therefore (\text{Side})^2 = 144$$

$$\text{Side} = \sqrt{144} = 12 \text{ m}$$

Now,

$$\text{Perimeter of square} = 4 \times \text{side} = 4 \times 12 = 48 \text{ m}$$

$$\text{Perimeter of rectangle} = 2(l + b) = 2(16 + 9) = 50 \text{ m}$$

$$\text{Hence, difference in their perimeters} = 50 - 48 = 2 \text{ m}$$

3. Two adjacent sides of a parallelogram are 24 cm and 18 cm. If the distance between longer sides is 12 cm, find the distance between shorter sides.

Solution:

Let take 24 cm as the base of parallelogram, then its height is 12 cm.

We know that,

$$\begin{aligned} \text{Area of parallelogram} &= \text{base} \times \text{height} \\ &= 24 \times 12 = 288 \text{ cm}^2 \end{aligned}$$

Let's consider d cm to be the distance between the shortest sides.

$$\therefore \text{Area of parallelogram} = (18 \times d) \text{ cm}^2$$

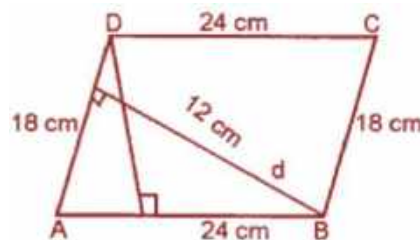

ML Aggarwal Solutions for Class 8 Maths

Chapter 18: Mensuration

$$18 \times d = 288$$

$$\Rightarrow d = 288/18 = 16 \text{ cm}$$

Therefore, the distance between the shorter sides is 16 cm.

4. Rajesh has a square plot with the measurement as shown in the given figure. He wants to construct a house in the middle of the plot. A garden is developed around the house. Find the total cost of developing a garden around the house at the rate of ₹50 per m².

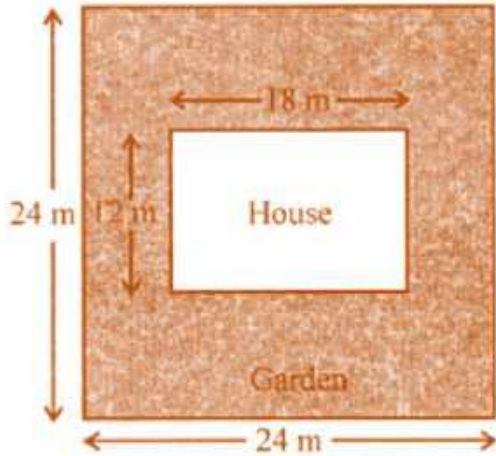

Solution:

Given,

Side of square plot = 24 m

Length of house (l) = 18 m
and breadth (b) = 12m

Now,

$$\text{Area of square plot} = (24)^2 \text{ m}^2 = (24 \times 24) \text{ m}^2 = 576 \text{ m}^2$$

And,

$$\text{Area of house} = 18 \times 12 = 216 \text{ m}^2$$

$$\text{Remaining area of the garden} = 576 \text{ m}^2 - 216 \text{ m}^2 = 360 \text{ m}^2$$

$$\text{The cost of developing the garden} = ₹50 \text{ per m}^2$$

$$\text{Therefore, the total cost} = ₹50 \times 360 = ₹18000$$

5. A flooring tile has a shape of a parallelogram whose base is 18 cm and the corresponding height is 6 cm. How many such tiles are required to cover a floor of area 540 m²? (If required you can split the tiles in whatever way you want to fill up the comers).

Solution:

Given,

Base of the parallelogram-shaped flooring tile = 18 cm and its height = 6 cm

So,

$$\begin{aligned} \text{Area of one tile} &= \text{Base} \times \text{Height} \\ &= 18 \times 6 \\ &= 108 \text{ cm}^2 \end{aligned}$$

$$\text{We have the area of floor} = 540 \text{ m}^2$$

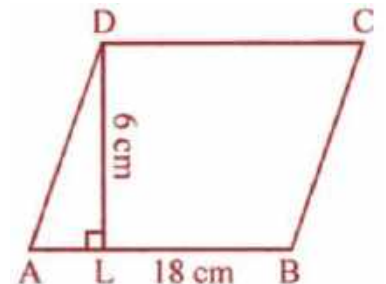

ML Aggarwal Solutions for Class 8 Maths Chapter 18: Mensuration

Hence, number of tiles = Total area/ Area of one tile
 $= (540 \times 100 \times 100)/108$ [As, $1 \text{ m}^2 = (100 \times 100) \text{ cm}^2$]
 $= 50000$

6. An ant is moving around a few food pieces of different shapes scattered on the floor. For which food piece would the ant have to take a longer round?

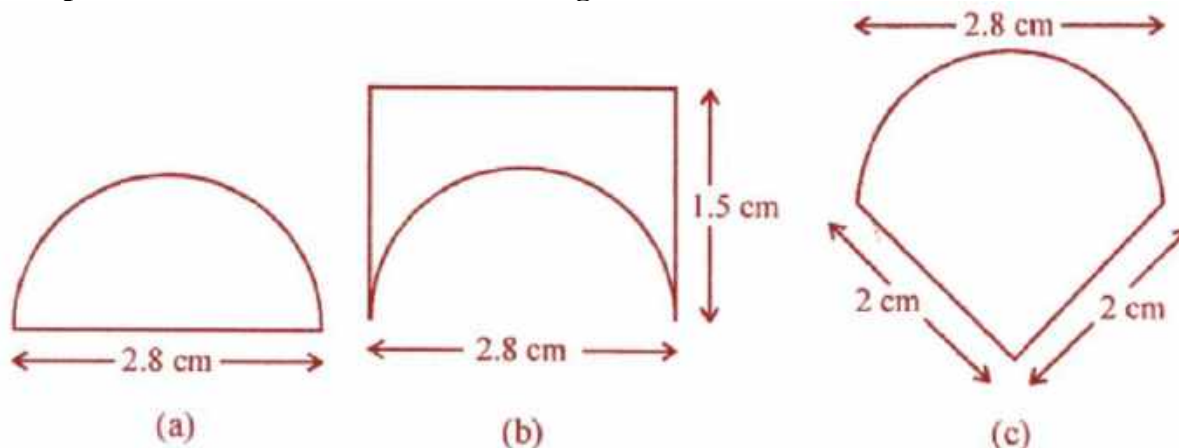

Solution:

(a) Diameter of semicircle = 2.8 cm

$$\begin{aligned} \therefore \text{Perimeter} &= \pi r + 2r \\ &= \frac{22}{7} \times 2.8 + 2 \times 2.8 \\ &= 8.8 + 5.6 \text{ cm} \\ &= 14.4 \text{ cm} \end{aligned}$$

$$\begin{aligned} \text{(b) Total perimeter} &= 1.5 + 1.5 + 2.8 + \text{semi circumference } (\pi r, \text{ where } r = 2.8/2 = 1.4 \text{ cm}) \\ &= 1.5 + 1.5 + 2.8 + (\frac{22}{7} \times 1.4) \\ &= 5.8 + 8.8 \\ &= 14.6 \text{ cm} \end{aligned}$$

$$\begin{aligned} \text{(c) Total perimeter} &= 2 + 2 + \text{Semi circumference } (\pi r, \text{ where } r = 2.8/2 = 1.4 \text{ cm}) \\ &= 4 + 8.8 \\ &= 12.8 \text{ cm} \end{aligned}$$

Hence, it is clearly seen that distance of (b) i.e. 14.6 is the longest.

7. In the adjoining figure, the area enclosed between the concentric circles is 770 cm^2 . If the radius of the outer circle is 21 cm, calculate the radius of the inner circle.

ML Aggarwal Solutions for Class 8 Maths
Chapter 18: Mensuration

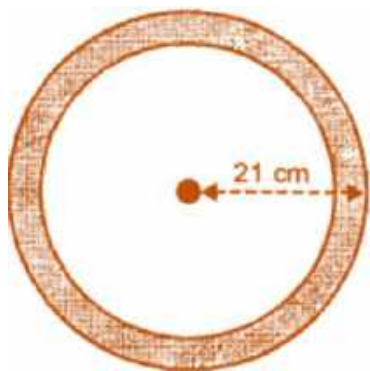

Solution:

Given,

Radius of outer circle (R) = 21 cm.

Radius of inner circle (r) = r cm.

Area of shaded portion = 770 cm^2

$$\Rightarrow \pi (R^2 - r^2) = 770$$

$$(21^2 - r^2) = 770$$

$$441 - r^2 = 770 \times (7/22) = 35 \times 7 = 245$$

$$r^2 = 441 - 245$$

$$r^2 = 196$$

$$r = \sqrt{196}$$

$$\therefore r = 14 \text{ cm}$$

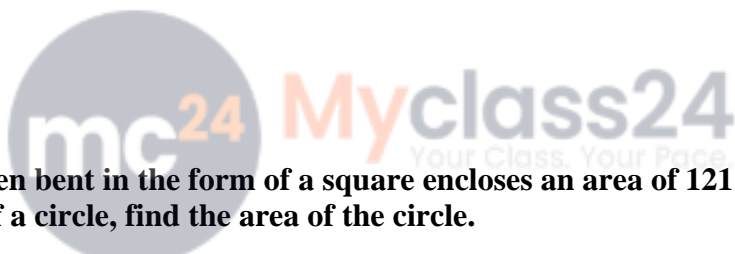

8. A copper wire when bent in the form of a square encloses an area of 121 cm^2 . If the same wire is bent into the form of a circle, find the area of the circle.

Solution:

Given,

Area of the square = 121 cm^2

So, side = $\sqrt{121} = 11 \text{ cm}$

Now,

Perimeter = $4a = 4 \times 11 = 44 \text{ cm}$

And, circumference of the circle = 44 cm

$$\therefore \text{Radius} = (44 \times 7) / (2 \times 22) = 7 \text{ cm}$$

$$\begin{aligned} \text{Therefore, area of the circle} &= \pi r^2 = (7)^2 \\ &= 22/7 \times 7 \times 7 \\ &= 154 \text{ cm}^2 \end{aligned}$$

9. From the given figure, find

(i) the area of $\triangle ABC$

(ii) length of BC

(iii) the length of altitude from A to BC

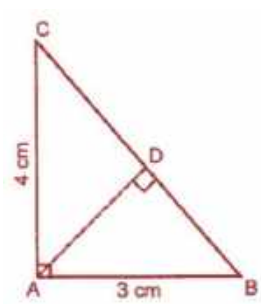

ML Aggarwal Solutions for Class 8 Maths

Chapter 18: Mensuration

Solution:

(i) We have,

Base = 3 cm and height = 4 cm.

Hence,

$$\begin{aligned}\text{Area} &= \frac{1}{2} \times \text{base} \times \text{height} \\ &= \frac{1}{2} \times 3 \times 4 \\ &= 6 \text{ cm}^2\end{aligned}$$

(ii) By Pythagoras theorem, we have

$$BC^2 = AB^2 + AC^2$$

$$\begin{aligned}BC^2 &= (3)^2 + (4)^2 \\ &= 9 + 16 = 25\end{aligned}$$

$$\Rightarrow BC = \sqrt{25} \text{ cm} = 5 \text{ cm}$$

(iii) Now,

Base = BC = 5 cm, h = AD = ?

So,

$$\text{Area} = \frac{1}{2} \times b \times h$$

$$6 = \frac{1}{2} \times 5 \times h \quad [\because \text{Area} = 6 \text{ cm}^2 \text{ as in part (i)}]$$

$$\Rightarrow h = \frac{12}{5} = 2.4 \text{ cm.}$$

10. A rectangular garden 80 m by 40 m is divided into four equal parts by two cross-paths 2.5 m wide. Find

(i) the area of the cross-paths.

(ii) the area of the unshaded portion.

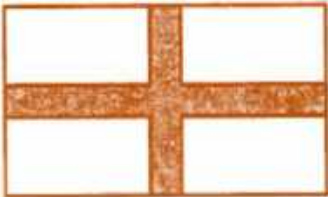

Solution:

Given,

Length of rectangular garden = 80 m

and breadth = 40 m

Width of crossing path 2.5 m

So,

$$\text{Area of length wise path} = 80 \times 2.5 = 200 \text{ m}^2$$

and

$$\text{Area of breadth wise path} = 40 \times 2.5 = 100 \text{ m}^2$$

(i) Total area of both paths

$$= 200 + 100 - 2.5 \times 2.5 \text{ m}^2$$

$$= 300 - 6.25 = 293.75 \text{ m}^2$$

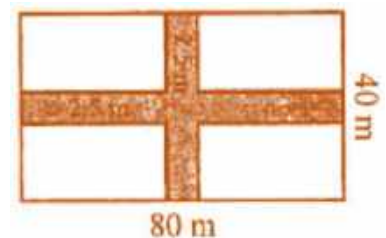

ML Aggarwal Solutions for Class 8 Maths Chapter 18: Mensuration

(ii) Area of unshaded portion
 = Area of garden – Area of paths
 = $80 \times 40 - 293.75 \text{ m}^2$
 = $3200 - 293.75 \text{ m}^2$
 = 2906.25 m^2

11. In the given figure, ABCD is a rectangle. Find the area of the shaded region.

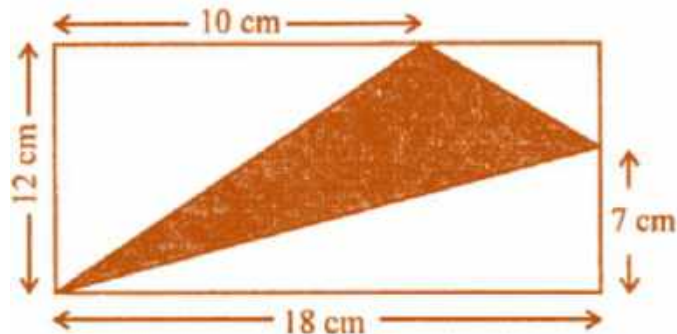

Solution:

In the given figure, we have
 Length of rectangle = 18 cm and breadth = 12 cm

$$\therefore \text{Area} = l \times b = 18 \times 12 \text{ cm}^2 = 216 \text{ cm}^2$$

$$\text{Area of triangle I} = \frac{1}{2} \times 12 \times 10 = 60 \text{ cm}^2$$

$$\text{Area of triangle III} = \frac{1}{2} \times 18 \times 7 = 63 \text{ cm}^2$$

Thus,

Area of shaded portion

$$= \text{Area of rectangle} - \text{Area of 3 triangles}$$

$$= 216 - (60 + 63 + 20)$$

$$= 216 - 143 \text{ cm}^2$$

$$= 73 \text{ cm}^2$$

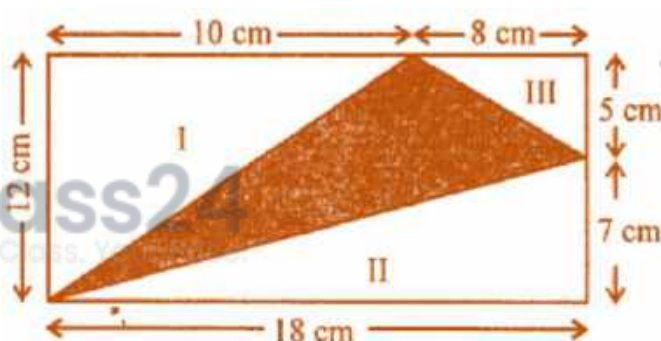

12. In the adjoining figure, ABCD is a square grassy lawn of area 729 m^2 . A path of uniform width runs all around it. If the area of the path is 295 m^2 , find

(i) the length of the boundary of the square field enclosing the lawn and the path.

(ii) the width of the path.

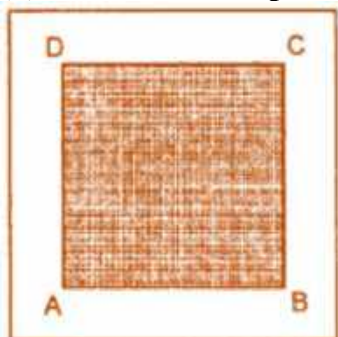

Solution:

ML Aggarwal Solutions for Class 8 Maths Chapter 18: Mensuration

Given,

$$\text{Area of square ABCD} = 729 \text{ m}^2$$

$$\text{So, its side} = \sqrt{729} = 27 \text{ m}$$

Let's take the width of path = x m

Then,

$$\text{Side of outer field} = 27 + x + x = (27 + 2x) \text{ m}$$

$$\text{And, area of square PQRS} = (27 + 2x)^2 \text{ m}^2$$

Now,

$$\text{Area of PQRS} - \text{Area of ABCD} = \text{Area of path}$$

$$\Rightarrow (27 + 2x)^2 \text{ m}^2 - 729 \text{ m}^2 = 295 \text{ m}^2$$

$$729 + 4x^2 + 108x - 729 = 295$$

$$4x^2 + 108x - 295 = 0$$

By using the quadratic formula, we have

$$a = 4, b = 108 \text{ and } c = -295$$

$$\Rightarrow x = \frac{-108 \pm \sqrt{(108)^2 - 4 \times (4) \times (-295)}}{8}$$

$$= \frac{-108 \pm \sqrt{11664 + 4720}}{8}$$

$$= \frac{-108 \pm \sqrt{16384}}{8} = \frac{-108 \pm 128}{8}$$

$$= \frac{20}{8} = 2.5 \quad (\text{Taking the positive root})$$

$$\left(\because x = \frac{-b \pm \sqrt{b^2 - 4ac}}{2a} \right)$$

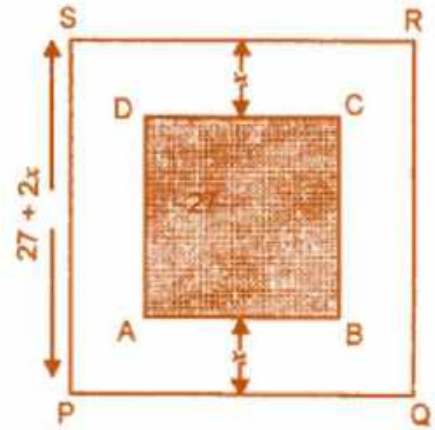

Hence,

Width of the path is 2.5 m

$$\text{Now, side of square field PQRS} = 27 + 2x$$

$$= (27 + 2 \times 2.5) \text{ m}$$

$$= 32 \text{ m}$$

Therefore,

$$\text{Length of boundary} = 4 \times \text{side} = 32 \times 4 = 128 \text{ m}$$

Exercise 18.2

1. Each sides of a rhombus is 13 cm and one diagonal is 10 cm. Find

(i) the length of its other diagonal

(ii) the area of the rhombus

Solution:

(i) Given,

Side of rhombus = 13 cm.

Length of diagonal AC = 10 cm.

\therefore OC = 5 cm.

Since, the diagonals of rhombus bisect each other at right angles

So, $\triangle BOC$ is rt. angled.

Then, by Pythagoras Theorem we have

$$BC^2 = OC^2 + OB^2$$

$$13^2 = 5^2 + OB^2$$

$$OB^2 = 169 - 25 = 144$$

$$\Rightarrow OB = \sqrt{144} = 12 \text{ cm}$$

Hence,

$$\text{Diagonal BD} = 2 \times OB = 2 \times 12 = 24 \text{ cm}$$

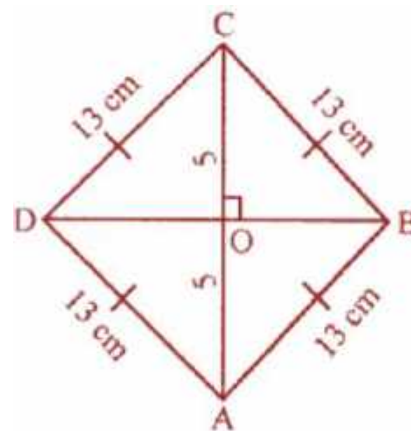

(ii) Area of rhombus = $\frac{1}{2} \times d_1 \times d_2$
 $= \frac{1}{2} \times 10 \times 24 = 120 \text{ cm}^2$

2. The cross-section ABCD of a swimming pool is a trapezium. Its width AB = 14 m, depth at the shallow end is 1.5 m and at the deep end is 8 m. Find the area of the cross-section.

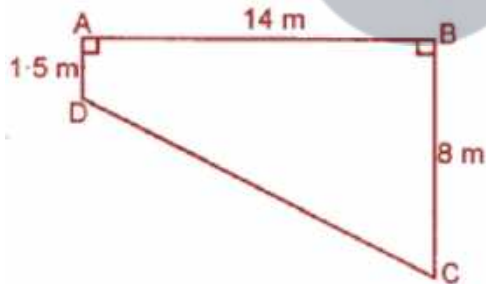

Solution:

Here, AD and BC are the two parallel sides of trapezium

And, distance between them is 14 m.

$$\therefore \text{Area of trapezium} = \frac{1}{2} (1.5 + 8) \times 14$$

$$= \frac{1}{2} \times 9.5 \times 14$$

$$= 66 \times 5 \text{ m}^2$$

3. The area of a trapezium is 360 m^2 , the distance between two parallel sides is 20 m and one of the parallel side is 25 m. Find the other parallel side.

Solution:

ML Aggarwal Solutions for Class 8 Maths Chapter 18: Mensuration

Given,

$$\text{Area of a trapezium} = 360 \text{ m}^2$$

$$\text{Distance between two parallel lines} = 20 \text{ m}$$

$$\text{One parallel side} = 25 \text{ m}$$

Now,

Let's assume the second parallel side to be x m

$$\text{So, Area} = (25 + x) \times 20$$

$$\Rightarrow 360 = (25 + x) \times 20$$

$$\therefore x = 36 - 25 = 11 \text{ m}$$

Therefore, the second parallel side is 11 m.

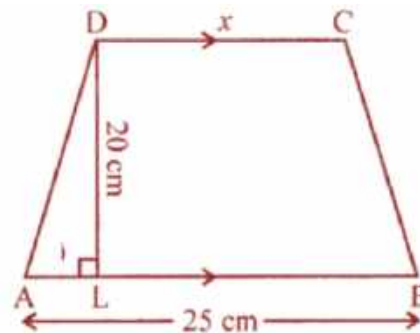

4. Find the area of a rhombus whose side is 6.5 cm and altitude is 5 cm. If one of its diagonal is 13 cm long, find the length of other diagonal.

Solution:

Given,

$$\text{Side of rhombus} = 6.5 \text{ cm}$$

$$\text{And altitude} = 5 \text{ cm}$$

So,

$$\text{Area of a rhombus} = \text{Side} \times \text{Altitude} = 6.5 \times 5 = 32.5 \text{ cm}^2$$

$$\text{We have, one diagonal} = 13 \text{ cm}$$

Hence,

$$\begin{aligned} \text{Length of other diagonal} &= (2 \times \text{Area}) / \text{One diagonal} \\ &= (32.5 \times 2) / 13 \\ &= 5 \text{ cm} \end{aligned}$$

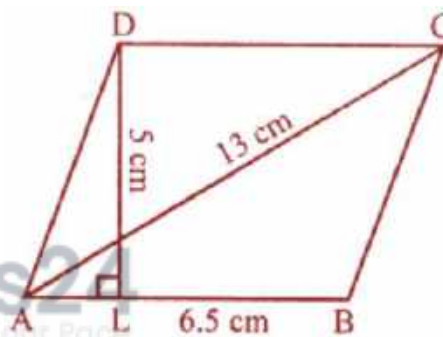

5. From the given diagram, calculate

(i) the area of trapezium ACDE

(ii) the area of parallelogram ABDE

(iii) the area of triangle BCD.

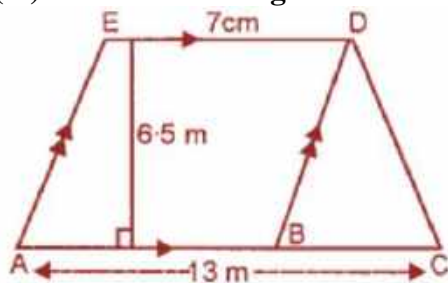

Solution:

$$\begin{aligned} \text{(i) Area of trapezium ACDE} &= \frac{1}{2} \times (AC + DE) \times h \\ &= \frac{1}{2} \times (13 + 7) \times 6.5 \\ &= \frac{1}{2} \times 20 \times 6.5 \\ &= 65 \text{ m}^2 \end{aligned}$$

$$\text{(ii) Area of parallelogram ABDE} = \frac{1}{2} \times b \times h$$

ML Aggarwal Solutions for Class 8 Maths Chapter 18: Mensuration

$$= \frac{1}{2} \times 6 \times 6.5$$

$$= 19.5 \text{ m}^2$$

(iii) Area of $\triangle BCD = \frac{1}{2} \times \text{base} \times \text{height}$
 $= \frac{1}{2} \times BC \times \text{height}$
 $= \frac{1}{2} \times 6 \times 6.5$
 $= 19.5 \text{ m}^2$

$$[\because BC = AC - AB = 13 - 7 = 6 \text{ m}]$$

6. The area of a rhombus is equal to the area of a triangle whose base and the corresponding altitude are 24.8 cm and 16.5 cm respectively. If one of the diagonals of the rhombus is 22 cm, find the length of the other diagonal.

Solution:

Given,

Base of triangle = 24.8 cm and altitude = 16.5 cm

$$\text{Area} = \frac{1}{2} \times \text{base} \times \text{altitude}$$

$$= \frac{1}{2} \times 24.8 \times 16.5 \text{ cm}^2$$

$$= 204.6 \text{ cm}^2$$

Now, Area of Δ = Area of rhombus

But, area of rhombus = 204.6 cm^2

Length of one diagonal = 22 cm

Area of rhombus = (First diagonal \times Second diagonal)

Thus,

$$\text{Second diagonal} = (2 \times \text{Area}) / \text{First diagonal}$$

$$= (204.6 \times 2) / 22$$

$$= 18.6 \text{ cm}$$

7. The perimeter of a trapezium is 52 cm. If its non-parallel sides are 10 cm each and its altitude is 8 cm, find the area of the trapezium.

Solution:

Given,

Perimeter of a trapezium = 52 cm

Length of each non-parallel side = 10 cm

Altitude DL = 8 cm

Now,

In right $\triangle DAL$, by Pythagoras Theorem we have

$$DA^2 = DL^2 + AL^2$$

$$(10)^2 = (8)^2 + AL^2$$

$$100 = 64 + AL^2$$

$$AL^2 = 100 - 64 = 36 = (6)^2$$

$$\therefore AL = 6 \text{ cm}$$

Similarly,

BM = 6 cm and DC = LM

Also, we have

Perimeter = AB + BC + CD + DA

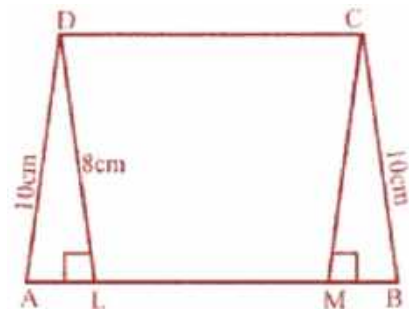

ML Aggarwal Solutions for Class 8 Maths

Chapter 18: Mensuration

$$\begin{aligned}
 &= [(AB + CD) \times (AF + FD)] \\
 &= [(AB + CD) \times (AF + FD)] \\
 &= [(5 + 3) \times (5 + 4)] \\
 &= (5 + 3) \times 9 \\
 &= 36 \text{ cm}^2
 \end{aligned}$$

Secondly,

$$\begin{aligned}
 \text{Area of rectangle GAFE} &= \text{Length} \times \text{Breadth} \\
 &= 2 \times 5 = 10 \text{ cm}^2
 \end{aligned}$$

Hence,

$$\begin{aligned}
 \text{Total area of the figure} &= \text{Area of trapezium ABCD} + \text{Area of rectangle GAFE} \\
 &= (36 + 10) \text{ cm}^2 \\
 &= 46 \text{ cm}^2
 \end{aligned}$$

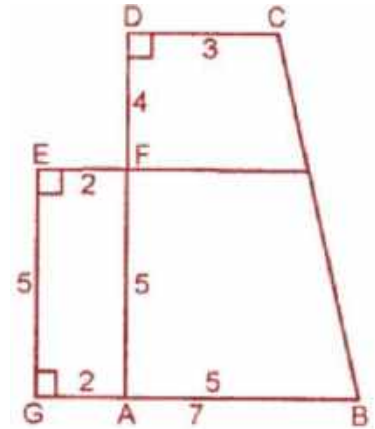

(ii) It's seen that,

Area of given figure = Area of rect. ABCD + Area of || gm BIHJ + Area of rectangle EFGH

$$\begin{aligned}
 \text{Area of rectangle ABCD} &= \text{Length} \times \text{Breadth} \\
 &= AD \times DC \\
 &= 9 \times 2 = 18 \text{ cm}^2
 \end{aligned}$$

And,

$$\begin{aligned}
 \text{Area of rectangle EFGH} &= \text{Length} \times \text{Breadth} \\
 &= (EJ + JH) \times EF \\
 &= (7 + 2) \times 2 \\
 &= 9 \times 2 = 18 \text{ cm}^2
 \end{aligned}$$

Now,

$$\begin{aligned}
 \text{Area of parallelogram BIHJ} &= 2 \times 5 = 10 \text{ cm}^2 \\
 &[\text{Since, distance between BI and HJ} = 9 - 2 - 2 = 5 \text{ cm}]
 \end{aligned}$$

Hence,

$$\text{Total area of the figure} = (18 + 18 + 10) \text{ cm}^2 = 46 \text{ cm}^2$$

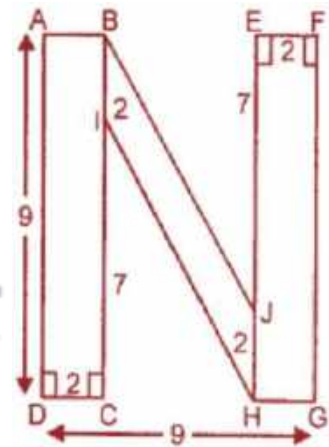

10. From the adjoining sketch, calculate

(i) the length AD

(ii) the area of trapezium ABCD

(iii) the area of triangle BCD

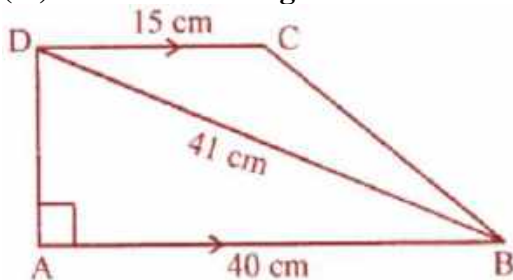

Solution:

(i) In right angled $\triangle ABD$, by Pythagoras Theorem we have

ML Aggarwal Solutions for Class 8 Maths Chapter 18: Mensuration

$$\begin{aligned}BD^2 &= AD^2 + AB^2 \\ \Rightarrow AD^2 &= BD^2 - AB^2 \\ &= (41)^2 - (40)^2 \\ &= 1681 - 1600 \\ &= 81 \\ \therefore AD &= \sqrt{81} = 9 \text{ cm}\end{aligned}$$

$$\begin{aligned}\text{(ii) Area of trapezium ABCD} &= (\text{Sum of opposite } \parallel \text{ gm lines}) \times \text{height} \\ &= (AB + CD) \times AD \\ &= (40 + 15) \times 9 \\ &= 247.5 \text{ cm}^2\end{aligned}$$

$$\begin{aligned}\text{(iii) Area of triangle BCD} &= \text{Area of trapezium ABCD} - \text{Area of } \Delta \text{ ABD} \\ &= (247.5 - \frac{1}{2} \times 40 \times 9) \text{ cm}^2 \\ &= (247.5 - 180) \text{ cm}^2 \\ &= 67.5 \text{ cm}^2\end{aligned}$$

11. Diagram of the adjacent picture frame has outer dimensions = 28 cm × 32 cm and inner dimensions 20 cm × 24 cm. Find the area of each section of the frame, if the width of each section is same.

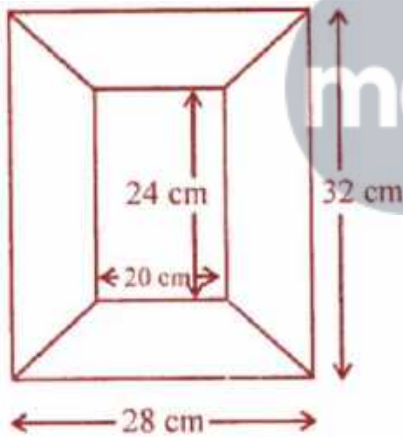

Solution:

Given,
Outer length of the frame = 32 cm and outer breadth = 28 cm
Inner length = 24 cm and outer breadth = 20 cm
So, width of the frame = $(32 - 24) / 2 = 4$ cm
 \Rightarrow Height = 4 cm
Now, area of each portion of length side
 $= \frac{1}{2} \times (24 + 32) \times 4$
 $= \frac{1}{2} \times 56 \times 4$
 $= 112 \text{ cm}^2$
And,
Area of each portion of breadth side

ML Aggarwal Solutions for Class 8 Maths Chapter 18: Mensuration

$$\begin{aligned}
 &= \frac{1}{2} \times (20 + 28) \times 4 \\
 &= \frac{1}{2} \times 48 \times 4 \\
 &= 96 \text{ cm}^2
 \end{aligned}$$

Therefore,

Area each section are 112 cm^2 , 96 cm^2 , 112 cm^2 , 96 cm^2 .

12. In the given quadrilateral ABCD, $\angle BAD = 90^\circ$ and $\angle BDC = 90^\circ$. All measurements are in centimetres. Find the area of the quadrilateral ABCD.

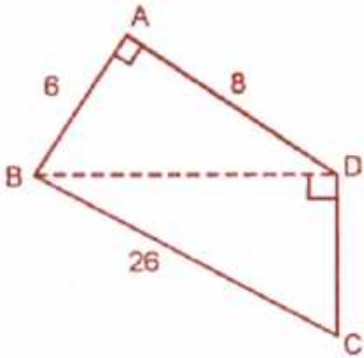

Solution:

In right angled triangle ABD, by Pythagoras Theorem we have

$$\begin{aligned}
 BD^2 &= AB^2 + AD^2 = (6)^2 + (8)^2 \\
 &= 36 + 64 \\
 &= 100 \text{ cm}^2
 \end{aligned}$$

$$\therefore BD = \sqrt{100} = 10 \text{ cm}$$

$$\begin{aligned}
 \text{Now, Area of } \triangle ABD &= \frac{1}{2} \times b \times h \\
 &= \frac{1}{2} \times 6 \times 8 \\
 &= 24 \text{ cm}^2 \dots \text{(i)}
 \end{aligned}$$

In $\triangle BDC$, we have

$$BD = 10 \text{ cm}, BC = 26 \text{ cm}$$

$$DC = ?$$

By Pythagoras theorem,

$$BC^2 = BD^2 + DC^2$$

$$(26)^2 = (10)^2 + DC^2$$

$$676 - 100 = DC^2$$

$$\Rightarrow DC = \sqrt{576} = 24 \text{ cm.}$$

Now,

$$\begin{aligned}
 \text{Area of } \triangle BDC &= \frac{1}{2} \times b \times h \\
 &= \frac{1}{2} \times 24 \times 10 \\
 &= 120 \text{ cm}^2 \dots \text{(ii)}
 \end{aligned}$$

Adding (i) and (ii), we get

$$\text{Area of } \triangle ABD + \text{Area of } \triangle BDC = (24 + 120) \text{ cm}^2$$

Hence,

$$\text{Area of quadrilateral ABCD} = 144 \text{ cm}^2$$

13. Top surface of a raised platform is in the shape of a regular octagon as shown in the given

ML Aggarwal Solutions for Class 8 Maths

Chapter 18: Mensuration

figure. Find the area of the octagonal surface.

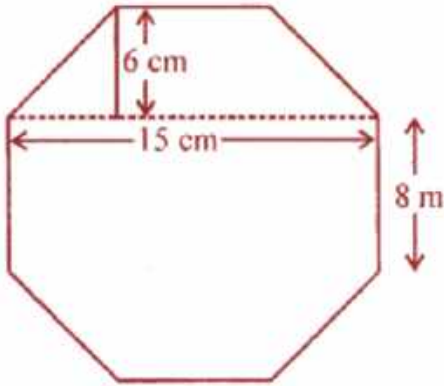

Solution:

The raised surface of platform is in the shape of regular octagon ABCDEFGH of each side = 8 cm.
Join HC.

$GD = HC = 15$ cm, $FL = AM = 6$ cm

Now, in each trapezium parallel sides are 15 cm and 6 cm and height = 6 cm

$$\begin{aligned} \text{So, Area of each trapezium FEDG} &= \frac{1}{2} (GD + FE) \times FL \\ &= \frac{1}{2} (15 + 8) \times 6 \\ &= 23 \times 3 \text{ cm}^2 \\ &= 69 \text{ cm}^2 \end{aligned}$$

Also,

Area of trapezium FEDG = Area of trapezium ABCH = 69 cm^2

$$\begin{aligned} \text{And area of rectangle HCDG} &= HC \times CD \\ &= 15 \times 8 \\ &= 120 \text{ cm}^2 \end{aligned}$$

Hence,

$$\begin{aligned} \text{Total area} &= \text{Area of trapezium FEDG} + \text{Area of trapezium ABCH} + \text{Area of rectangle HCDG} \\ &= 69 + 69 + 120 \\ &= 258 \text{ cm}^2 \end{aligned}$$

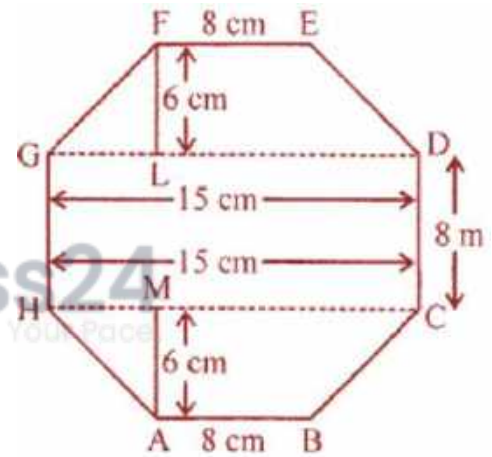

14. There is a pentagonal shaped park as shown in the following figure:

For finding its area Jaspreet and Rahul divided it in two different ways.

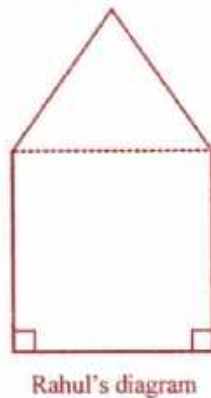
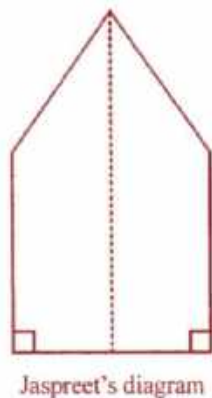
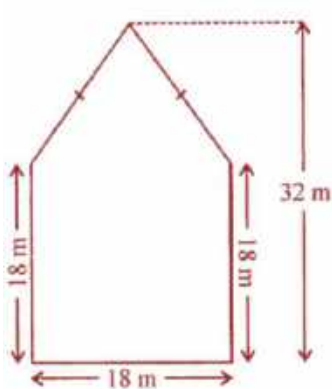

ML Aggarwal Solutions for Class 8 Maths

Chapter 18: Mensuration

Find the area of this park using both ways. Can you suggest some other way of finding its area?
Solution:

The pentagonal shaped park is shown in the given figure.
In which $DL \perp CE$ and is produced to M .

So, $DM = 32$ m

$LM = CB = 18$ m

$\therefore DL = 32 - 18 = 14$ m

(i) According to Jaspreet's the figure is divided into two equal trapezium in area: DEAM and DCBM

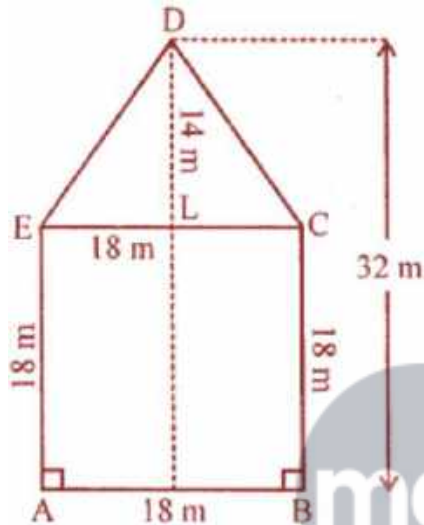

Now,

$$\begin{aligned}\text{Area of trapezium DEAM} &= \frac{1}{2} (AE + DM) \times AM \\ &= \frac{1}{2} (32 + 18) \times 9 \\ &= \frac{(50 \times 9)}{2} \\ &= 225\text{m}^2\end{aligned}$$

(ii) According to Rahul's the figure is divided into shapes: one square and one isosceles triangle.

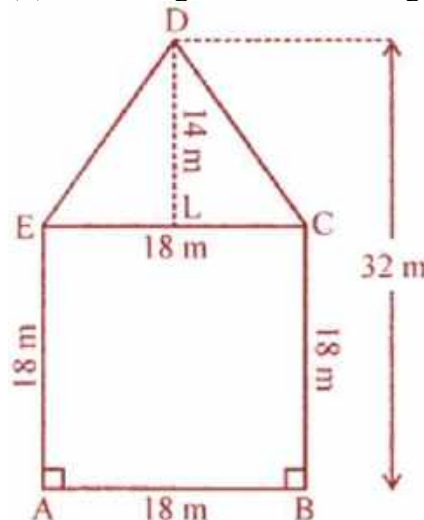

ML Aggarwal Solutions for Class 8 Maths Chapter 18: Mensuration

$$\begin{aligned} \text{Area of square ABCE} &= (\text{Side})^2 \\ &= (18)^2 \\ &= 324 \text{ m}^2 \end{aligned}$$

$$\begin{aligned} \text{And, area of isosceles } \triangle EDC &= \frac{1}{2} \times EC \times DC \\ &= \frac{1}{2} \times 18 \times 14 \\ &= 126 \text{ m}^2 \end{aligned}$$

$$\therefore \text{Total area} = 225 \times 2 = 450 \text{ m}^2$$

The third way to find out the area of given figure is as follow:

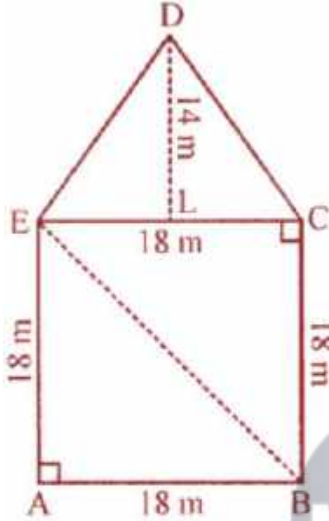

Here, $DL \perp EC$ and $DL = 14 \text{ m}$

$$\begin{aligned} \text{Area of } \triangle DEC &= \frac{1}{2} \times EC \times DL \\ &= \frac{1}{2} \times 18 \times 14 \\ &= 126 \text{ m}^2 \end{aligned}$$

$$\begin{aligned} \text{Area of } \triangle AEB &= \frac{1}{2} \times AB \times AE \\ &= \frac{1}{2} \times 18 \times 18 \\ &= 162 \text{ m}^2 \end{aligned}$$

$$\begin{aligned} \text{Area of } \triangle BEC &= \frac{1}{2} \times BC \times EC \\ &= \frac{1}{2} \times 18 \times 18 = 162 \text{ m}^2 \end{aligned}$$

$$\begin{aligned} \text{Hence, area of pentagon ABCDE} &= \text{Area } \triangle DEC + \text{Area of } \triangle AEB + \text{Area of } \triangle BEC \\ &= (126 + 162 + 162) \text{ m}^2 \\ &= 450 \text{ m}^2 \end{aligned}$$

15. In the diagram, ABCD is a rectangle of size 18 cm by 10 cm. In $\triangle BEC$, $\angle E = 90^\circ$ and $EC = 8 \text{ cm}$. Find the area enclosed by the pentagon ABECD.

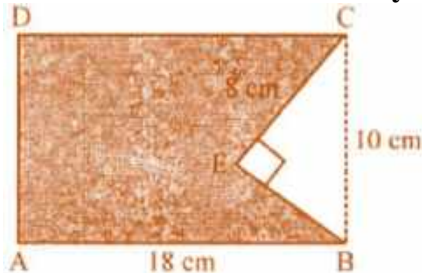

ML Aggarwal Solutions for Class 8 Maths

Chapter 18: Mensuration

Solution:

$$\begin{aligned}\text{Area of rectangle ABCD} &= \text{Length} \times \text{Breadth} \\ &= 18 \times 10 \\ &= 180 \text{ cm}^2\end{aligned}$$

In right angled Δ BEC,

By Pythagoras theorem, we have

$$BC^2 = CE^2 + BE^2$$

$$(10)^2 = 8^2 + BE^2$$

$$BE^2 = 100 - 64 = 36$$

$$\Rightarrow BE = \sqrt{36} = 6 \text{ cm.}$$

So,

$$\begin{aligned}\text{Area of rt. } \Delta \text{ BEC} &= \frac{1}{2} \times 6 \times 8 \\ &= 24 \text{ cm}^2\end{aligned}$$

$$\begin{aligned}\text{Area of pentagon ABECD} &= \text{Area of rectangle} - \text{area of } \Delta \\ &= (180 - 24) \text{ cm}^2 \\ &= 156 \text{ cm}^2\end{aligned}$$

16. Polygon ABCDE is divided into parts as shown in the given figure. Find its area if $AD = 8 \text{ cm}$, $AH = 6 \text{ cm}$, $AG = 4 \text{ cm}$, $AF = 3 \text{ cm}$ and perpendiculars $BF = 2 \text{ cm}$, $CH = 3 \text{ cm}$, $EG = 2.5 \text{ cm}$.

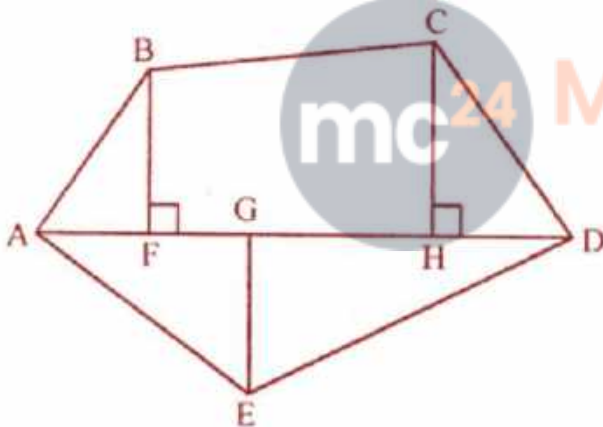

Solution:

In the given figure, ABCDE, $AD = 8 \text{ cm}$, $AH = 6 \text{ cm}$, $AG = 4 \text{ cm}$, $AF = 3 \text{ cm}$ \perp $BF = 2 \text{ cm}$ $CH = 3 \text{ cm}$ and \perp $EG = 2.5 \text{ cm}$

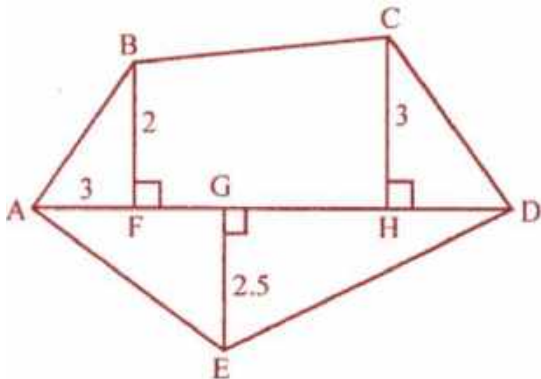

ML Aggarwal Solutions for Class 8 Maths Chapter 18: Mensuration

The given figure, consists of 3 triangles and one trapezium.

Now,

$$\begin{aligned}\text{Area of } \triangle AED &= \frac{1}{2} \times AD \times GE \\ &= \frac{1}{2} \times 8 \times 2.5 \\ &= 10 \text{ cm}^2\end{aligned}$$

$$\begin{aligned}\text{Area of } \triangle ABF &= \frac{1}{2} \times AF \times BF \\ &= \frac{1}{2} \times 3 \times 2 \\ &= 3 \text{ cm}^2\end{aligned}$$

$$\begin{aligned}\text{Area of } \triangle CDH &= \frac{1}{2} \times HD \times CH \\ &= \frac{1}{2} \times (AD - AH) \times 3 \\ &= \frac{1}{2} \times (8 - 6) \times 3 \\ &= \frac{1}{2} \times 2 \times 3 \\ &= 3 \text{ cm}^2\end{aligned}$$

$$\begin{aligned}\text{Area of trapezium BFHC} &= \frac{1}{2} \times (BF + CH) \times FH \\ &= \frac{1}{2} \times (2 + 3) \times (AH - AF) \\ &= \frac{1}{2} \times 5 \times (6 - 3) \\ &= \frac{1}{2} \times 5 \times 3 \\ &= 7.5 \text{ cm}^2\end{aligned}$$

Hence,

$$\begin{aligned}\text{Total area of the figure} &= \text{Area of } \triangle AED + \text{Area of } \triangle ABF + \text{Area of } \triangle CDH + \text{Area of trapezium BFHC} \\ &= 10 + 3 + 3 + 7.5 \\ &= 23.5 \text{ cm}^2\end{aligned}$$

17. Find the area of polygon PQRSTU shown in 1 the given figure, if PS = 11 cm, PY = 9 cm, PX = 8 cm, PW = 5 cm, PV = 3 cm, QV = 5 cm, UW = 4 cm, RX = 6 cm, TY = 2 cm.

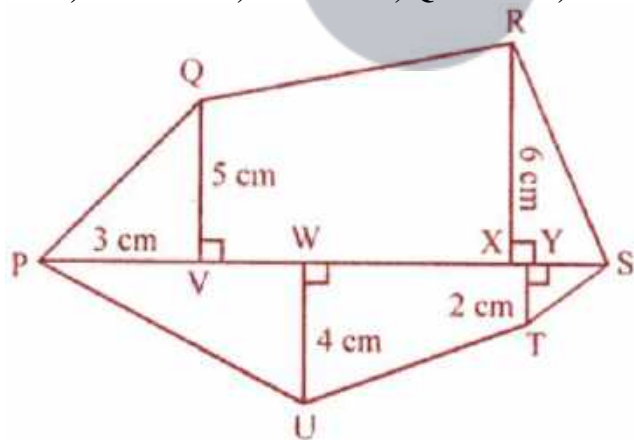

Solution:

In the figure PQRSTU, we have

PS = 11 cm, PY = 9 cm, PX = 8 cm, PW = 5 cm, PV = 3 cm, QV = 5 cm, UW = 4 cm, RX = 6 cm and TY = 2 cm

And,

The figure consists of 4 triangle and 2 trapeziums

From the figure its seen that,

$$VX = PX - PV$$

ML Aggarwal Solutions for Class 8 Maths
Chapter 18: Mensuration

$$= 8 - 3$$

$$= 5 \text{ cm}$$

$$XS = PS - PX$$

$$= 11 - 8$$

$$= 3 \text{ cm}$$

$$YS = PS - PY$$

$$= 11 - 9$$

$$= 2 \text{ cm}$$

$$WY = PY - PW$$

$$= 9 - 5$$

$$= 4 \text{ cm}$$

Now,

$$\text{Area } \Delta PQV = \frac{1}{2} \times PV \times QV$$

$$= \frac{1}{2} \times 3 \times 5 = 15/2$$

$$= 7.5 \text{ cm}^2$$

$$\text{Area of } \Delta RXS = \frac{1}{2} \times XS \times RX$$

$$= \frac{1}{2} \times 3 \times 6$$

$$= 9 \text{ cm}^2$$

$$\text{Area of } \Delta PUW = \frac{1}{2} \times PW \times UW$$

$$= \frac{1}{2} \times 5 \times 4$$

$$= 10 \text{ cm}^2$$

$$\text{Area } \Delta YTS = \frac{1}{2} \times YS \times TY$$

$$= \frac{1}{2} \times 2 \times 2$$

$$= 2 \text{ cm}^2$$

$$\text{Area of trapezium } \Delta VX R = \frac{1}{2} \times (QV + RX) \times VX$$

$$= \frac{1}{2} \times (5 + 6) \times 5$$

$$= \frac{1}{2} \times 11 \times 5 \text{ cm}^2$$

$$= 55/2$$

$$= 27.5 \text{ cm}^2$$

$$\text{Area of trapezium } WUTY = \frac{1}{2} \times (UW + TY) \times WY$$

$$= \frac{1}{2} \times (4 + 2) \times 4$$

$$= \frac{1}{2} \times 6 \times 4$$

$$= 12 \text{ cm}^2$$

Hence,

$$\text{Area of the figure} = (7.5 + 9 + 10 + 2 + 27.5 + 12) \text{ cm}^2 = 68 \text{ cm}^2.$$

Exercise 18.3

1. The volume of a cube is 343 cm^3 , find the length of an edge of cube.

Solution:

Given,

$$\text{Volume of a cube} = 343 \text{ cm}^3$$

Let's consider 'a' to be the edge of cube, then

$$V = a^3 = 343 = (7)^3$$

$$\therefore a = 7 \text{ cm}$$

2. Fill in the following blanks:

	Volume of cuboid	Length	Breadth	Height
(i)	90 cm^3	-	5 cm	3 cm
(ii)	-	15 cm	8 cm	7 cm
(iii)	62.5 m^3	10 cm	5 cm	-

Solution:

Volume of cuboid = length x Breadth x Height

$$(i) 90 \text{ cm}^3 = \text{length} \times 5 \text{ cm} \times 3 \text{ cm}$$

$$\text{Length} = 90 / (5 \times 3) = 90 / 15 = 6 \text{ cm}$$

$$(ii) \text{Volume} = 15 \text{ cm} \times 8 \text{ cm} \times 7 \text{ cm} \\ = 840 \text{ cm}^3$$

$$(iii) 62.5 \text{ m}^3 = 10 \text{ m} \times 5 \text{ m} \times \text{height}$$

$$\text{Height} = 62.5 / (10 \times 5) = 1.25 \text{ m}$$

	Volume of cuboid	Length	Breadth	Height
(i)	90 cm^3	6 cm	5 cm	3 cm
(ii)	840 cm^3	15 cm	8 cm	7 cm
(iii)	62.5 m^3	10 cm	5 cm	1.25 m

3. Find the height of a cuboid whose volume is 312 cm^3 and base area is 26 cm^2 .

Solution:

Given,

$$\text{Volume of a cuboid} = 312 \text{ cm}^3$$

$$\text{Base area} = l \times b = 26 \text{ cm}^2$$

$$\therefore \text{Height} = \text{Volume} / \text{Base area} = 312 / 26 = 12 \text{ cm}$$

4. A godown is in the form of a cuboid of measures $55 \text{ m} \times 45 \text{ m} \times 30 \text{ m}$. How many cuboidal boxes can be stored in it if the volume of one box is 1.25 m^3 ?

Solution:

Given,

ML Aggarwal Solutions for Class 8 Maths

Chapter 18: Mensuration

Length of a godown (l) = 55 m

Breadth (b) = 45 m

Height (h) = 30 m

So,

$$\begin{aligned}\text{Volume} &= l \times b \times h \\ &= (55 \times 45 \times 30) \text{ m}^3 \\ &= 74250 \text{ m}^3\end{aligned}$$

Also given, volume of one box = 1.25 m^3

Thus,

Number of boxes = $74250/1.25 = 59400$ boxes

5. A rectangular pit 1.4 m long, 90 cm broad and 70 cm deep was dug and 1000 bricks of base 21 cm by 10.5 cm were made from the earth dug out. Find the height of each brick.

Solution:

Here $l = 1.4 \text{ m} = 140 \text{ cm}$, $b = 90 \text{ cm}$ and $h = 70 \text{ cm}$

$$\begin{aligned}\text{Volume of rectangular pit} &= l \times b \times h \\ &= (140 \times 90 \times 70) \text{ cm}^3 \\ &= 882000 \text{ cm}^3\end{aligned}$$

Volume of brick = $21 \times 10.5 \times h$

Now,

Number of bricks = Volume of pit / Volume of brick

$$1000 = 882000 / (21 \times 10.5 \times h)$$

$$h = 882000 / (21 \times 10.5 \times 1000)$$

$$= 4 \text{ cm}$$

Thus, the height of each brick is 4 cm.

6. If each edge of a cube is tripled, then find how many times will its volume become?

Solution:

Let's consider the edge of a cube to be x

Then, its volume = x^3

Now, if the edge is tripled

Edge = $3x$

So, volume = $(3x)^3 = 27x^3$

\therefore Its volume is 27 times the volume of the given cube.

7. A milk tank is in the form of cylinder whose radius is 1.4 m and height is 8 m. Find the quantity of milk in litres that can be stored in the tank.

Solution:

Given,

Radius of the milk cylindrical tank = 1.4 m and height (h) = 8 m

Hence,

$$\begin{aligned}\text{Volume of milk in the tank} &= \pi r^2 h \\ &= (22/7) \times 1.4 \times 1.4 \times 8 \text{ m}^3\end{aligned}$$

ML Aggarwal Solutions for Class 8 Maths
Chapter 18: Mensuration

$$\begin{aligned} &= 49.28 \text{ m}^3 \\ &= 49.28 \times 1000 \text{ litres} \\ &= 49280 \text{ litres} \end{aligned}$$

Therefore, the quantity of the tank is 49280 litres.

8. A closed box is made of 2 cm thick wood with external dimension 84 cm × 75 cm × 64 cm. Find the volume of the wood required to make the box.

Solution:

Given,

Thickness of the wood used in a closed box = 2 cm

External length of box (L) = 84 cm

Breadth (b) = 75 cm and height (h) = 64 cm

$$\begin{aligned} \text{So, internal length (l)} &= 84 - (2 \times 2) \\ &= 84 - 4 \\ &= 80 \text{ cm} \end{aligned}$$

$$\begin{aligned} \text{Breadth (b)} &= 75 - (2 \times 2) \\ &= 75 - 4 \\ &= 71 \text{ cm} \end{aligned}$$

$$\begin{aligned} \text{and height (h)} &= 64 - (2 \times 2) \\ &= 64 - 4 \\ &= 60 \text{ cm} \end{aligned}$$

$$\begin{aligned} \text{Hence, Volume of wood used} &= 84 \times 75 \times 64 - 80 \times 71 \times 60 \text{ cm}^3 \\ &= 403200 - 340800 \text{ cm}^3 \\ &= 62400 \text{ cm}^3 \end{aligned}$$

9. Two cylindrical jars contain the same amount of milk. If their diameters are in the ratio 3 : 4, find the ratio of their heights.

Solution:

Given,

Ratio in diameters of two cylindrical jars = 3 : 4

But their volumes are same.

Let's assume h_1 and h_2 to be the heights of the two jars respectively.

Let radius of the first jar (r_1) = $3x/2$

and radius of the second jar (r_2) = $4x/2$

Then according to the condition in the problem, we have

$$\pi r_1^2 h_1 = \pi r_2^2 h_2$$

$$\pi \left(\frac{3x}{2} \right)^2 h_1 = \pi \left(\frac{4x}{2} \right)^2 h_2$$

$$\frac{9}{4} x^2 h_1 = \frac{16}{4} x^2 h_2$$

ML Aggarwal Solutions for Class 8 Maths
Chapter 18: Mensuration

$$\frac{h_1}{h_2} = \frac{16}{4} x^2 \times \frac{4}{9x^2} = \frac{16}{9}$$

Therefore, the ratio in their heights = 16 : 9

10. The radius of the base of a right circular cylinder is halved and the height is doubled. What is the ratio of the volume of the new cylinder to that of the original cylinder?

Solution:

Let's consider the radius of a cylinder to be r

And height = h

So,

$$\text{Volume} = \pi r^2 h$$

Now, its radius is halved and height is doubled, then

$$\begin{aligned}\text{Volume} &= \pi (r/2)^2 \times (2h) \\ &= \pi r^2 h / 2\end{aligned}$$

Thus, the ratio in the volumes of the new cylinder to old one is

$$\begin{aligned}&= \pi r^2 h / 2 : \pi r^2 h \\ &= 1 : 2\end{aligned}$$

11. A rectangular piece of tin of size 30 cm × 18 cm is rolled in two ways, once along its length (30 cm) and once along its breadth. Find the ratio of volumes of two cylinders so formed.

Solution:

Given,

Size of rectangular tin plate = 30 cm × 18 cm

(i) When rolled along its length (30 cm),

Then, the circumference of the circle so formed = 30 cm

$$\text{Radius}(r_1) = C/2\pi = (30 \times 7) / (2 \times 22) = 105/22 \text{ cm}$$

And height (h_1) = 18 cm

$$\text{Then, volume} = \pi r_1^2 h_1 = \pi \times (105/22)^2 \times (18) \text{ cm}^3$$

If it is rolled along its breadth (18 cm) then,

Circumference = 18 cm

$$\text{So, radius } (r_2) = C/2\pi = (18 \times 7) / (2 \times 22) = 63/22 \text{ cm}$$

And height (h_2) = 30 cm

$$\text{Then, volume} = \pi r_2^2 h_2 = \pi \times (63/22)^2 \times (30) \text{ cm}^3$$

Now, ratio between the two volumes

$$\begin{aligned}&= \pi \times (105/22)^2 \times (18) : \pi \times (63/22)^2 \times (30) \\ &= (105/22)^2 \times (18) : (63/22)^2 \times (30) \\ &= 5 : 3\end{aligned}$$

12. Water flows through a cylindrical pipe of internal diameter 7 cm at 5 m per sec. Calculate

(i) the volume in litres of water discharged by the pipe in one minute.

(ii) the time in minutes, the pipe would take to fill an empty rectangular tank of size 4 m × 3 m × 2.31 m.

Solution:

ML Aggarwal Solutions for Class 8 Maths
Chapter 18: Mensuration

Given,

Speed of water flow through cylindrical pipe = 5 m/sec.

Internal diameter of the pipe = 7 cm

So, radius (r) = 7/2 cm

Now, length of water flow in 1 minutes (h) = 5 × 60 = 300 m

$$\begin{aligned}\therefore \text{Volume of water} &= \pi r^2 h \\ &= \frac{22}{7} \times \frac{7}{2} \times \frac{7}{2} \times 300 \times 100 \text{ cm}^3 \\ &= 1155000 \text{ cm}^3 = 1155 \text{ litres}\end{aligned}$$

(i) the volume of water = 1155000 cm³

$$\begin{aligned}\text{Volume of rectangular tank of size} &= 4\text{m} \times 3\text{m} \times 2.31\text{m} \\ &= 27.72 \text{ m}^3\end{aligned}$$

Also given, speed of water = 4 m/sec.

Radius of pipe = 7/2 cm

$$\begin{aligned}\text{Volume of water in 1 sec} &= \frac{22}{7} \times \frac{7}{2} \times \frac{7}{2} \times 5 \times 100 \text{ cm}^3 \\ &= 19250 \text{ cm}^3\end{aligned}$$

Hence,

$$\begin{aligned}\text{(ii) Time taken to empty the tank} &= \frac{27.72 \text{ m}^3}{19250} \\ &= \frac{(2772 \times 100 \times 100 \times 100)}{(100 \times 19250)} \text{ sec} \\ &= 1440 \text{ sec} \\ &= 1440/60 = 24 \text{ minutes}\end{aligned}$$

13. Two cylindrical vessels are filled with milk. The radius of one vessel is 15 cm and height is 40 cm, and the radius of other vessel is 20 cm and height is 45 cm. Find the radius of another cylindrical vessel of height 30 cm which may just contain the milk which is in the two given vessels.

Solution:

Given,

Radius of one cylinder (r₁) = 15 cm

And height (h₁) = 40 cm

Radius of second cylinder (r₂) = 20 cm

And height (h₂) = 45 cm

Now,

$$\begin{aligned}\text{Volume of first cylinder} &= \pi r_1^2 h_1 \\ &= \frac{22}{7} \times 15 \times 15 \times 40 \text{ cm}^3 \\ &= 198000/7 \text{ cm}^3\end{aligned}$$

And,

$$\begin{aligned}\text{Volume of second cylinder} &= \pi r_2^2 h_2 \\ &= \frac{22}{7} \times 20 \times 20 \times 45 \\ &= 396000/7 \text{ cm}^3\end{aligned}$$

$$\begin{aligned}\text{So, total volume} &= (198000/7 + 396000/7) \text{ cm}^3 \\ &= 594000/7 \text{ cm}^3\end{aligned}$$

Now, volume of third cylinder = 594000/7 cm³

And height = 30 cm

Thus,

ML Aggarwal Solutions for Class 8 Maths
Chapter 18: Mensuration

$$\begin{aligned}\text{Radius} &= \sqrt[3]{\frac{594000}{7} \times \frac{7}{22} \times \frac{1}{30}} \\ &= \sqrt[3]{900} = 30 \text{ cm}\end{aligned}$$

∴ Radius of the third cylinder = 30 cm

14. A wooden pole is 7 m high and 20 cm in diameter. Find its weight if the wood weighs 225 kg per m³.

Solution:

Given,

Height of pole (h) = 7 m

Diameter = 20 cm

So, radius (r) = 20/2 = 10 cm = 10/100 = 1/10 m

And,

$$\begin{aligned}\text{Volume} &= \pi r^2 h \\ &= \frac{22}{7} \times \frac{1}{10} \times \frac{1}{10} \times 7 \text{ m}^3 \\ &= \frac{22}{100} \text{ m}^3\end{aligned}$$

Weight of wood = 225 kg per m³

Hence,

$$\text{Total weight} = 225 \times \left(\frac{22}{100}\right) = \frac{99}{2} = 49.5 \text{ kg}$$

15. A cylinder of maximum volume is cut from a wooden cuboid of length 30 cm and cross-section a square of side 14 cm. Find the volume of the cylinder and the volume of the wood wasted.

Solution:

A cylinder of the maximum volume is cut from a wooden cuboid of length 30 cm and cross-section a square side 14 cm.

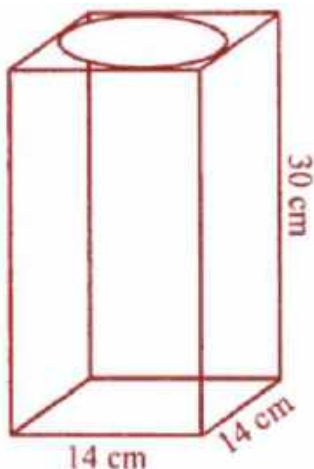

So,

Diameter of the cylinder = 14 cm

$$\Rightarrow \text{Radius (r)} = \frac{14}{2} = 7 \text{ cm}$$

and height (h) = 30 cm

ML Aggarwal Solutions for Class 8 Maths Chapter 18: Mensuration

$$\text{Volume of cuboid} = 30 \times 14 \times 14 = 5880 \text{ cm}^3$$

$$\begin{aligned}\text{Volume of cylinder} &= \pi r^2 h \\ &= \frac{22}{7} \times 7 \times 7 \times 30 \\ &= 4620 \text{ cm}^3\end{aligned}$$

Hence,

$$\text{The wastage of wood} = 5880 - 4620 = 1260 \text{ cm}^3$$



Exercise 18.4

1. The surface area of a cube is 384 cm^2 . Find

(i) the length of an edge

(ii) volume of the cube.

Solution:

Given,

Surface area of a cube = 384 cm^2

(i) Surface area of cube = $6(\text{side})^2$

Hence, edge (side) = $\sqrt{(\text{surface area}/6)}$

$$= \sqrt{(384/6)}$$

$$= \sqrt{64}$$

$$= 8 \text{ cm}$$

(ii) Volume = $(\text{Edge})^3 = (8)^3 = 8 \times 8 \times 8 \text{ cm}^3 = 512 \text{ cm}^3$

2. Find the total surface area of a solid cylinder of radius 5 cm and height 10 cm. Leave your answer in terms of π .

Solution:

Given,

Radius of a solid cylinder (r) = 5 cm

Height (h) = 10 cm

Hence,

Total surface area = $2\pi rh + 2\pi r^2$

$$= 2r\pi(h + r)$$

$$= 2\pi \times 5(10 + 5)$$

$$= \pi \times 10 \times 15$$

$$= 150\pi \text{ cm}^2$$

3. An aquarium is in the form of a cuboid whose external measures are $70 \text{ cm} \times 28 \text{ cm} \times 35 \text{ cm}$. The base, side faces and back face are to be covered with coloured paper. Find the area of the paper needed.

Solution:

Given, a cuboid shaped aquarium

Length (l) = 70 cm

Breadth (b) = 28 cm

and height (h) = 35 cm

Now,

Area of base = $70 \times 28 \text{ cm}^2$

$$= 1960 \text{ cm}^2$$

Area of side face = $(28 \times 35) \times 2 \text{ cm}^2$

$$= 1960 \text{ cm}^2$$

Area of back face = $70 \times 35 \text{ cm}^2$

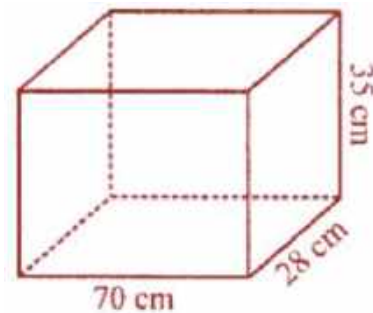

ML Aggarwal Solutions for Class 8 Maths Chapter 18: Mensuration

$$= 2450 \text{ cm}$$

Thus, the total area = $1960 + 1960 + 2450 = 6370 \text{ cm}^2$

Hence, area of paper required is 6370 cm^2 .

4. The internal dimensions of rectangular hall are $15 \text{ m} \times 12 \text{ m} \times 4 \text{ m}$. There are 4 windows each of dimension $2 \text{ m} \times 1.5 \text{ m}$ and 2 doors each of dimension $1.5 \text{ m} \times 2.5 \text{ m}$. Find the cost of white washing all four walls of the hall, if the cost of white washing is ₹5 per m^2 . What will be the cost of white washing if the ceiling of the hall is also white washed?

Solution:

Given,

Internal dimension of rectangular hall = $15 \text{ m} \times 12 \text{ m} \times 4 \text{ m}$

Now,

$$\begin{aligned}\text{Area of 4-walls} &= 2(l + b) \times h \\ &= 2(15 + 12) \times 4 \\ &= 2 \times 27 \times 4 \text{ m}^2 \\ &= 216 \text{ m}^2\end{aligned}$$

Area of 4 windows of size = $(2 \times 1.5) \times 4 = 12 \text{ m}^2$

Area of 2 door of size = $2 \times (1.5 \times 2.5) = 7.5 \text{ m}^2$

So, area of remaining hall = $216 - (12 + 7.5) = 216 - 19.5 \text{ m}^2 = 196.5 \text{ m}^2$

And,

Cost of white washing the walls all four walls of the house is at the rate of ₹5 per m^2
 $= 196.5 \times 5 = ₹982.50$

Area of ceiling = $l \times b = 15 \times 12 = 180 \text{ m}^2$

Cost of white washing = $180 \times 5 = ₹900$

Therefore, the total cost for white washing = $₹982.50 + 900.00$
 $= ₹1882.50$

5. A swimming pool is 50 m in length, 30 m in breadth and 2.5 m in depth. Find the cost of cementing its floor and walls at the rate of ₹27 per square metre.

Solution:

Given,

Length of swimming pool = 50 m

Breadth of swimming pool = 30 m

Depth (Height) of swimming pool = 2.5 m

Now,

Area of floor = $50 \times 30 = 1500 \text{ m}^2$

Area of four walls = $2(50 + 30) \times 2.5 = 160 \times 2.5 = 400 \text{ m}^2$

So, the area to be cemented = $1500 \text{ m}^2 + 400 \text{ m}^2 = 1900 \text{ m}^2$

Cost of cementing $1 \text{ m}^2 = ₹27$

Hence,

Cost of cementing $1900 \text{ m}^2 = ₹27 \times 1900 = ₹51300$

6. The floor of a rectangular hall has a perimeter 236 m. Its height is 4.5 m. Find the cost of painting its four walls (doors and windows be ignored) at the rate of Rs. 8.40 per square metre.

ML Aggarwal Solutions for Class 8 Maths
Chapter 18: Mensuration

Solution:

Given,

Perimeter of Hall = 236 m.

Height = 4.5 m

Perimeter = $2(l + b) = 236$ m

Area of four walls = $2(l + b) \times h$
 $= 236 \times 4.5$
 $= 1062 \text{ m}^2$

We have, cost of painting $1 \text{ m}^2 = ₹8.40$

Hence,

Cost of painting $1062 \text{ m}^2 = ₹8.40 \times 1062 = ₹8920.80$

7. A cuboidal fish tank has a length of 30 cm, a breadth of 20 cm and a height of 20 cm. The tank is placed on a horizontal table and it is three-quarters full of water. Find the area of the tank which is in contact with water.

Solution:

Given,

Length of tank = 30 cm

Breadth of tank = 20 cm

Height of tank = 20 cm

As the tank is three-quarters full of water

So, the height of water in the tank = $(20 \times 3)/4 = 15$ cm

Hence,

Area of the tank in contact with the water = Area of floor of Tank + Area of 4 walls upto 15 cm
 $= 30 \times 20 + 2(30 + 20) \times 15$
 $= 600 + 2 \times 50 \times 15$
 $= 600 + 1500 = 2100 \text{ cm}^2$

8. The volume of a cuboid is 448 cm^3 . Its height is 7 cm and the base is a square. Find

(i) a side of the square base

(ii) surface area of the cuboid.

Solution:

Given,

Volume of a cuboid = 448 cm^3

Height = 7 cm

So, area of base = $448/7 = 64 \text{ cm}^2$

Thus, the base is a square.

(i) Side of square base = $\sqrt{64} = 8$ cm

(ii) Surface area of the cuboid = $2[lb + bh + hl]$
 $= 2[8 \times 8 + 8 \times 7 + 7 \times 8] \text{ cm}^2$
 $= 2[64 + 56 + 56]$
 $= 2 \times 176 = 352 \text{ cm}^2$

ML Aggarwal Solutions for Class 8 Maths

Chapter 18: Mensuration

9. The length, breadth and height of a rectangular solid are in the ratio 5 : 4 : 2. If its total surface area is 1216 cm², find the volume of the solid.

Solution:

Given that the ratio in length, breadth and height of a rectangular solid = 5 : 4 : 2

Total surface area = 1216 cm²

Let's assume the length = 5x, breadth = 4x and height = 2x

$$\begin{aligned}\text{Total surface area} &= 2[5x \times 4x + 4x \times 2x + 2x \times 5x] \\ &= 2[20x^2 + 8x^2 + 10x^2] \\ &= 2 \times 38x^2 \\ &= 76x^2\end{aligned}$$

$$\text{So, } 76x^2 = 1216$$

$$\Rightarrow x^2 = 1216/76 = 16 = (4)^2$$

$$\therefore x = 4$$

Hence, the dimensions of the rectangular solid are

$$\text{Length} = 5 \times 4 = 20 \text{ cm}$$

$$\text{Breadth} = 4 \times 4 = 16 \text{ cm}$$

$$\text{Height} = 2 \times 4 = 8 \text{ cm}$$

$$\text{and volume} = lbh = 20 \times 16 \times 8 = 2560 \text{ cm}^3$$

10. A rectangular room is 6 m long, 5 m wide and 3.5 m high. It has 2 doors of size 1.1 m by 2 m and 3 windows of size 1.5 m by 1.4 m. Find the cost of whitewashing the walls and the ceiling of the room at the rate of ₹5.30 per square metre.

Solution:

Given, Length of room = 6 m

Breadth of room = 5 m

Height of room = 3.5 m

$$\begin{aligned}\text{So, Area of four walls} &= 2(l + b) \times h \\ &= 2(6 + 5) \times 3.5 \\ &= 77 \text{ m}^2\end{aligned}$$

$$\begin{aligned}\text{Area of 2 doors and 3 windows} &= (2 \times 1.1 \times 2 + 3 \times 1.5 \times 1.4) \\ &= (4.4 + 6.3) \text{ m}^2 \\ &= 10.7 \text{ m}^2\end{aligned}$$

$$\text{Area of ceiling} = l \times b = 6 \times 5 = 30 \text{ m}^2$$

Thus,

$$\text{Total area for white washing} = (77 - 10.7 + 30) \text{ m}^2 = 96.3 \text{ m}^2$$

$$\text{Hence, the cost of white washing} = ₹(96.3 \times 5.30) = ₹510.39$$

11. A cuboidal block of metal has dimensions 36 cm by 32 cm by 0.25 m. It is melted and recast into cubes with an edge of 4 cm.

(i) How many such cubes can be made?

(ii) What is the cost of silver coating the surfaces of the cubes at the rate of ₹0.75 per square centimetre?

Solution:

ML Aggarwal Solutions for Class 8 Maths
Chapter 18: Mensuration

(i) Given, Length of cuboid = 36 cm

Breadth of cuboid = 32 cm

Height of cuboid = $0.25 \times 100 = 25$ cm

So,

Volume of cuboid = $l b h$

$$= (36 \times 32 \times 25) \text{ cm}^3$$

$$= 28800 \text{ cm}^3$$

Volume of cube = $(\text{side})^2$

$$= (4)^2$$

$$= 64 \text{ cm}^2$$

Hence, the number of cubes recasting from cuboid = $28800/64 = 450$

(ii) Surface area of 1 cube = $6 \times a^2$

$$= 6 \times 16$$

$$= 96 \text{ cm}^2$$

So, the surface area of 450 cubes = 96×450

$$= 43200 \text{ cm}^2$$

Hence, the cost of silver coating on cubes = $\text{₹}0.75 \times 43200$

$$= \text{₹}32400$$

12. Three cubes of silver with edges 3 cm, 4 cm and 5 cm are melted and recast into a single cube, find the cost of coating the surface of the new cube with gold at the rate of ₹3.50 per square centimetre?

Solution:

Let's consider a cm to be the edge of new cube

Then, according to given conditions in the question

$$a^3 = 3^3 + 4^3 + 5^3$$

$$= 27 + 64 + 125$$

$$= 216 \text{ cm}^3$$

$$a = \sqrt[3]{216}$$

$$\therefore a = 6 \text{ cm}$$

So, the surface area of new cube = $6 \times (\text{side})^2$

$$= 6 \times (6)^2$$

$$= 216 \text{ cm}^2$$

Hence, the cost of coating the surface of new cube = $\text{₹}3.50 \times 216 = \text{₹}156$

13. The curved surface area of a hollow cylinder is 4375 cm^2 , it is cut along its height and formed a rectangular sheet of width 35 cm. Find the perimeter of the rectangular sheet.

Solution:

Given, curved surface area of a hollow cylinder = 4375 cm^2

By cutting it from the height,

L Aggarwal Solutions for Class 8 Maths
Chapter 18: Mensuration

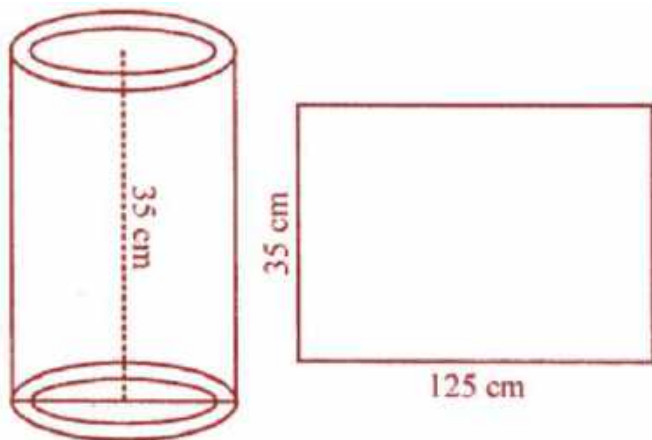

It becomes a rectangular sheet whose width = 35 cm

So, the height of cylinder = 35 cm
And, length of sheet = Area/Height
= $4375/35$
= 125 cm

Hence, Perimeter of the sheet = $2(l + b)$
= $2 \times (125 + 35)$
= 2×160
= 320 cm

14. A road roller has a diameter 0.7 m and its width is 1.2 m. Find the least number of revolutions that the roller must take in order to level a playground of size 120 m × 44 m.

Solution:

Given,

Diameter of a road roller = 0.7 m = 70 cm
So, radius (r) = $70/2$ cm = 35 cm = $35/100$ m
and width (h) = 1.2 m

Now,

Curved surface area = $2\pi rh$
= $(2 \times 22/7 \times 35/100 \times 1.2)$ m²
= $264/100$ m²

Area of playground = 120 m × 44 m
= 120×44 m²
= 5280 m²

Hence, the number of revolution made by the road roller = $(5280/264) \times 100$
= 2000 revolutions

15. A company packages its milk powder in cylindrical container whose base has a diameter of 14 cm and height 20 cm. Company places a label around the surface of the container (as shown in the figure). If the label is placed 2 cm from top and bottom, what is the area of the label?

ML Aggarwal Solutions for Class 8 Maths
Chapter 18: Mensuration

Solution:

Given,

Diameter of cylindrical container = 14 cm

So, radius (r) = $14/2 = 7$ cm

And, height (h) = 20 cm

Now,

Width of label = $20 - (2 + 2)$ cm = $20 - 4 = 16$ cm

Hence, area of label = $2\pi rh$
 $= 2 \times (22/7) \times 7 \times 16$
 $= 704$ cm²

16. The sum of the radius and height of a cylinder is 37 cm and the total surface area of the cylinder is 1628 cm². Find the height and the volume of the cylinder.

Solution:

Given,

Sum of height and radius of a cylinder = 37 cm

Total surface area = 1628 cm²

Let's consider the radius to be r

Then, height = $(37 - r)$ cm

Now,

Total surface area = $2\pi(h + r)$

$$1628 = \frac{2 \times 22}{7} \times r(37)$$

$$\Rightarrow \frac{1628 \times 7}{2 \times 22 \times 37} = r$$

$$\Rightarrow r = 7 \text{ cm}$$

$$\text{Height} = 37 - 7 = 30 \text{ cm}$$

Hence,

$$\begin{aligned} \text{Volume} &= \pi r^2 h \\ &= (22/7) \times 7 \times 7 \times 30 \text{ cm}^3 \\ &= 4620 \text{ cm}^3 \end{aligned}$$

17. The ratio between the curved surface and total surface of a cylinder is 1 : 2. Find the volume of the cylinder, given that its total surface area is 616 cm².

Solution:

Given that ratio between curved surface and total surface area of a cylinder = 1 : 2

Total surface area = 616 cm²

So, curved surface area = $616/2 = 308$ cm²

And,

Area of two circular faces = $616 - 308 = 308$ cm²

Area of one circular face = $308/2 = 154$ cm²

Now, let's consider the radius to be r

ML Aggarwal Solutions for Class 8 Maths
Chapter 18: Mensuration

$$\pi r^2 = 154$$

$$(22/7) \times r^2 = 154$$

$$r^2 = (154 \times 7) / 22 = 49$$

$$\Rightarrow r = 49 = \sqrt{7} \text{ cm}$$

$$\text{Hence, the volume} = \pi r^2 h = (22/7) \times 7 \times 7 \times 7 = 1078 \text{ cm}^2$$

18. The given figure shown a metal pipe 77 cm long. The inner diameter of cross section is 4 cm and the outer one is 4.4 cm.

Find its

(i) inner curved surface area

(ii) outer curved surface area

(iii) total surface area.

Solution:

Given,

Length of metal pipe (h) = 77 cm

Inner diameter = 4 cm

and outer diameter = 4.4 cm

So, inner radius (r) = $4/2 = 2$ cm

And outer radius (R) = $4.4/2 = 2.2$ cm

(i) Inner curved surface area = $2\pi r h$
 $= 2 \times 22/7 \times 2 \times 77 \text{ cm}^2$
 $= 968 \text{ cm}^2$

(ii) Outer surface area = $2\pi R h$
 $= 2 \times 22/7 \times 2.2 \times 77 \text{ cm}^2$
 $= 1064.8 \text{ cm}^2$

(iii) Surface area of upper and lower rings = $2[\pi R^2 - \pi r^2]$
 $= 2 \times 22/7 (2.2^2 - 2^2) \text{ cm}^2$
 $= 44/7 \times 4.2 \times 0.2$
 $= 5.28 \text{ cm}^2$

Hence,

$$\text{Total surface area} = (968 + 1064.8 + 5.28) \text{ cm}^2 = 2038.08 \text{ cm}^2$$

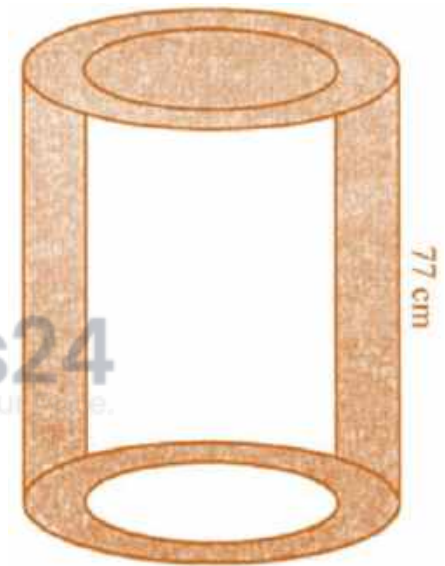

Check Your Progress

1. A square field of side 65 m and rectangular field of length 75 m have the same perimeter. Which field has a larger area and by how much?

Solution:

Given,

Side of a square field = 65 m

So, perimeter = $4 \times \text{Side}$

$$= 4 \times 65$$

$$= 260 \text{ m}$$

Now, perimeter of a rectangular field = 260 m

And given, length (l) = 75 m

Perimeter of rectangle = $2(l + b)$

$$\Rightarrow 260 = 2(75 + b)$$

$$260 = 150 + 2b$$

$$2b = 260 - 150$$

$$b = 110/2 = 55 \text{ m}$$

Then,

Area of square field = $(\text{side})^2$

$$= (65)^2 \text{ m}^2$$

$$= 4225 \text{ m}^2$$

And, area of rectangular field = $l \times b$

$$= 75 \times 55 \text{ m}^2$$

$$= 4125 \text{ m}^2$$

Hence, it is clear that area of square field is greater.

Difference = $4225 - 4125$

$$= 100 \text{ m}^2$$

2. The shape of a top surface of table is a trapezium. Find the area if its parallel sides are 1.5 m and 2.5 m and perpendicular distance between them is 0.8 m.

Solution:

Shape of the top of a table is trapezium and parallel sides are 1.5 m and

2.5 m and the perpendicular distance between them = 0.8m

Hence,

Area = $\frac{1}{2} \times (\text{Sum of parallel sides}) \times \text{height}$

$$= \frac{1}{2} \times (1.5 + 2.5) \times 0.8$$

$$= \frac{1}{2} \times 4 \times 0.8 \text{ m}^2$$

$$= 1.6 \text{ m}^2$$

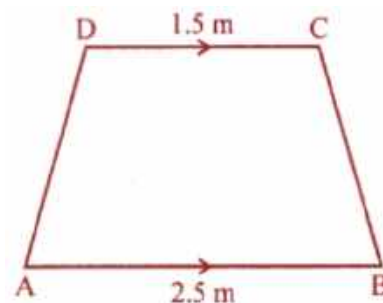

3. The length and breadth of a hall of a school are 26 m and 22 m respectively. If one student requires 1.1 sq. m area, then find the maximum number of students to be seated in this hall.

Solution:

Given, length of a school hall (l) = 26 m and breadth (b) = 22 m

ML Aggarwal Solutions for Class 8 Maths

Chapter 18: Mensuration

$$\begin{aligned}\text{So, area} &= l \times b \\ &= 26 \times 22 \text{ m}^2 \\ &= 572 \text{ m}^2\end{aligned}$$

One student requires 1.1 sq. m area

$$\begin{aligned}\text{Hence, number of students} &= 572/1.1 \\ &= (572 \times 10)/11 \\ &= 520 \text{ students}\end{aligned}$$

4. It costs ₹936 to fence a square field at ₹7.80 per metre. Find the cost of levelling the field at ₹2.50 per square metre.

Solution:

Given,

Cost of fencing the square field at ₹7.80 per metre = ₹936.

So, total fence required will be = $936/7.80 = 120$

Thus, the perimeter of the field = 120 m

$$\Rightarrow 4 \times \text{Side} = 120 \text{ m} \quad [\text{Since, it's a square field}]$$

$$\Rightarrow \text{Side} = 120/4$$

$$\therefore \text{Side} = 30 \text{ m}$$

$$\begin{aligned}\text{Hence, Area of square field} &= (30)^2 = 900 \text{ m}^2 \\ &= 900 \times 2.50 = ₹2250\end{aligned}$$

5. Find the area of the shaded portion in the following figures all measurements are given in cm.

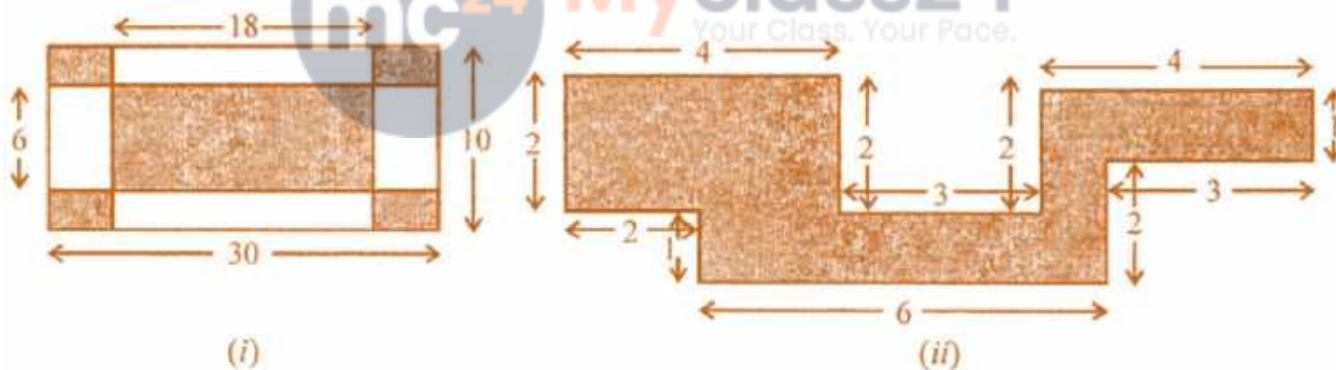

Solution:

(i) Outer length = 30 cm

Breadth = 10 cm

Side of each rectangle of the corner (l) = $(30 - 18)/2 = 6$ cm

and b = $(10 - 6)/2 = 4/2 = 2$ cm

So,

$$\begin{aligned}\text{Area of 4 corner} &= (6 \times 2) \times 4 \\ &= 48 \text{ cm}^2\end{aligned}$$

$$\begin{aligned}\text{And area of inner rectangle} &= 18 \times 6 \\ &= 108 \text{ cm}^2\end{aligned}$$

Therefore,

ML Aggarwal Solutions for Class 8 Maths

Chapter 18: Mensuration

$$\text{Area of shaded portion} = 108 + 48 = 156\text{cm}^2$$

$$\text{(ii) Area of rectangle I} = 4 \times 2 = 8\text{ cm}^2$$

$$\text{Area of rectangle II} = 4 \times 1 = 4\text{ cm}^2$$

$$\text{Area of rectangle III} = 6 \times 1 = 6\text{ cm}^2$$

$$\text{and area of square IV} = 1 \times 1 = 1\text{ Cm}^2$$

$$\therefore \text{Total area of shaded portion} = 8 + 4 + 6 + 1 = 19\text{ cm}^2$$

6. Area of a trapezium is 160 sq. cm. Lengths of parallel sides are in the ratio 1:3. If smaller of the parallel sides is 10 cm in length, then find the perpendicular distance between them.

Solution:

Given,

$$\text{Area of trapezium} = 160\text{ cm}^2$$

$$\text{Ratio of the length of its parallel sides} = 1 : 3$$

$$\text{Smaller parallel side} = 10\text{ cm}$$

Then,

$$\text{Length of greater side} = 10 \times 3 = 30\text{ cm}$$

$$\text{Now, distance between them} = h$$

$$\therefore h = \frac{\text{Area} \times 2}{\text{Sum of parallel sides}} = \frac{160 \times 2}{10 + 30}$$

$$= \frac{160 \times 2}{40} = 8\text{ cm}$$



7. The area of a trapezium is 729 cm² and the distance between two parallel sides is 18 cm. If one of its parallel sides is 3 cm shorter than the other parallel side, find the lengths of its parallel sides.

Solution:

Given,

$$\text{Area of a trapezium} = 729\text{ cm}^2$$

$$\text{Distance between two parallel sides (Altitude)} = 18\text{ cm}$$

$$\text{So, the sum of parallel sides} = (\text{Area} \times 2) / \text{Altitude}$$

$$= (729 \times 2) / 18$$

$$= 81\text{ cm}$$

One parallel side is shorter than the second by 3 cm

Let the longer side be taken as x

$$\text{Then, shorter side} = x - 3$$

According to the question, we have

$$\Rightarrow x + x - 3 = 81$$

$$2x = 81 + 3 = 84$$

$$x = 84/2 = 42$$

Hence, the longer side = 42 cm and shorter side = 42 - 3 = 39 cm

8. Find the area of the polygon given in the figure:

ML Aggarwal Solutions for Class 8 Maths
Chapter 18: Mensuration

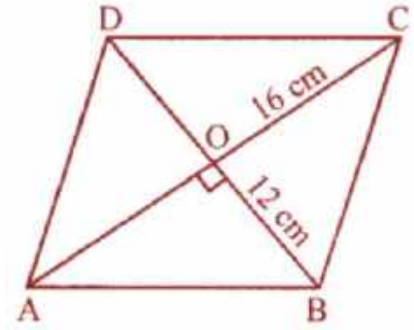

$$\begin{aligned} \text{(i) Area} &= (d_1 \times d_2) / 2 \\ &= (16 \times 12) / 2 \\ &= 96 \text{ cm}^2 \end{aligned}$$

(ii) As the diagonals of rhombus bisect each other at right angles, we have

$$AO = OC \text{ and } BO = OD$$

$$AO = 16/2 = 8 \text{ cm and } BO = 12/2 = 6 \text{ cm}$$

Now, in right $\triangle AOB$

$$\begin{aligned} AB^2 &= AO^2 + BO^2 && \text{[By Pythagoras Theorem]} \\ &= 8^2 + 6^2 \\ &= 64 + 36 \\ &= 100 = (10)^2 \end{aligned}$$

$$\therefore AB = 10 \text{ cm}$$

Therefore, the side of rhombus = 10 cm

10. The area of a parallelogram is 98 cm^2 . If one altitude is half the corresponding base, determine the base and the altitude of the parallelogram.

Solution:

Given,

$$\text{Area of a parallelogram} = 98 \text{ cm}^2$$

One altitude = Half of its corresponding base

Let's consider the base as $x \text{ cm}$

Then altitude = $x/2 \text{ cm}$

So, area = Base \times Altitude

$$\Rightarrow 98 = x \times (x/2)$$

$$x^2 = 98 \times 2$$

$$= 196$$

$$= (14)^2$$

$$\therefore x = 14$$

Therefore, Base = 14 cm and altitude = 7 cm

11. Preeti is painting the walls and ceiling of a hall whose dimensions are $18 \text{ m} \times 15 \text{ m} \times 5 \text{ m}$. From each can of paint 120 m^2 of area is painted. How many cans of paint does she need to paint the hall?

Solution:

Given,

Length of a hall (l) = 18 m

Breadth (b) = 15m and

height (h) = 5 m

So,

$$\begin{aligned} \text{Area of 4-wall and ceiling} &= 2(l + b)h + lb \\ &= 2(18 + 15) \times 5 + 18 \times 15 \text{ m}^2 \\ &= 2 \times 33 \times 5 + 270 \end{aligned}$$

ML Aggarwal Solutions for Class 8 Maths Chapter 18: Mensuration

$$\begin{aligned} &= 330 + 270 \\ &= 600 \text{ m}^2 \end{aligned}$$

From 1 can an area of 120 m^2 can be painted

Hence, total number of cans required to paint the area of $600 \text{ m}^2 = 600/120 = 5$ cans

12. A rectangular paper is size $22 \text{ cm} \times 14 \text{ cm}$ is rolled to form a cylinder of height 14 cm , find the volume of the cylinder. (Take $\pi = 22/7$)

Solution:

Given,

Length of a rectangular paper = 22 cm and breadth = 14 cm

By rolling it a cylinder is formed whose height is 14 cm

And, circumference of the base = 22 cm

We know that, circumference = $2\pi r$

So, radius (r) = $C/2\pi = (22 \times 7)/(2 \times 22) = 7/2 \text{ cm}$

Hence,

$$\begin{aligned} \text{Volume of the cylinder so formed} &= \pi r^2 h \\ &= 22/7 \times 7/2 \times 7/2 \times 14 \\ &= 539 \text{ cm}^3 \end{aligned}$$

13. A closed rectangular wooden box has inner dimensions 90 cm by 80 cm by 70 cm . Compute its capacity and the area of the tin foil needed to line its inner surface.

Solution:

Given,

Inner length of rectangular box = 90 cm

Inner breadth of rectangular box = 80 cm

Inner height of rectangular box = 70 cm

Now,

$$\begin{aligned} \text{Capacity of rectangular box} &= \text{Volume of rectangular box} \\ &= l \times b \times h \\ &= 90 \text{ cm} \times 80 \text{ cm} \times 70 \text{ cm} \\ &= 504000 \text{ cm}^3 \end{aligned}$$

And,

$$\begin{aligned} \text{Required area of tin foil} &= 2(lb + bh + lh) \\ &= 2(90 \times 80 + 80 \times 70 + 90 \times 70) \text{ cm}^2 \\ &= 2(7200 + 5600 + 6300) \text{ cm}^2 \\ &= 2 \times 19100 \text{ cm}^2 \\ &= 38200 \text{ cm}^2 \end{aligned}$$

14. The lateral surface area of a cuboid is 224 cm^2 . Its height is 7 cm and the base is a square. Find

(i) side of the square base

(ii) the volume of the cuboid.

Solution:

ML Aggarwal Solutions for Class 8 Maths Chapter 18: Mensuration

Given,

Lateral surface area of a cuboid is 224 cm^2

Height (h) = 7 cm

$$(i) 2(l + b) \times h = 224$$

$$\Rightarrow 2(l + b) \times 7 = 224$$

$$l + b = 224/14 = 16 \text{ cm}$$

But $l = b$ [Since, the base of cuboid is a square]

$$\text{So, } 2 \times \text{side} = 16 \text{ cm}$$

$$\Rightarrow \text{Side} = 16/2 = 8 \text{ cm}$$

$$(ii) \text{ Volume of cuboid} = lbh = 8 \times 8 \times 7 \text{ cm}^3 = 448 \text{ cm}^3$$

15. The inner dimensions of a closed wooden box are 2 m by 1.2 m by 0.75 m. The thickness of the wood is 2.5 cm. Find the cost of wood required to make the box if 1 m^3 of wood costs ₹5400.

Solution:

Given,

Inner dimensions of wooden box are 2 m, 1.2 m, 0.75 m

Thickness of the wood = 2.5 cm = $2.5/100 \text{ m} = 0.025 \text{ m}$

Now,

External dimensions of wooden box are

$$= (2 + 2 \times 0.025), (1.2 + 2 \times 0.025), (0.75 + 2 \times 0.025)$$

$$= (2 + 0.05), (1.2 + 0.05), (0.75 + 0.05)$$

$$= 2.05, 1.25, 0.80$$

Thus,

Volume of solid = External volume of box – Internal volume of box

$$= 2.05 \times 1.25 \times 0.80 \text{ m}^3 - 2 \times 1.2 \times 0.75 \text{ m}^3$$

$$= 2.05 - 1.80 = 0.25 \text{ m}^3$$

Given, the cost of wood = ₹5400 for 1 m^3

Hence,

$$\text{Total cost} = ₹5400 \times 0.25 = ₹5400 \times 25/100$$

$$= ₹54 \times 25$$

$$= ₹1350$$

16. A car has a petrol tank 40 cm long, 28 cm wide and 25 cm deep. If the fuel consumption of the car averages 13.5 km per litre, how far can the car travel with a full tank of petrol?

Solution:

Given,

$$\text{Capacity of car tank} = 40 \text{ cm} \times 28 \text{ cm} \times 25 \text{ cm} = (40 \times 28 \times 25) \text{ cm}^3$$

$$= (40 \times 28 \times 25)/1000 \text{ litre} \quad [\because 1000 \text{ cm}^3 = 1 \text{ litre}]$$

Average fuel consumption of car = 13.5 km per litres

Then, the distance travelled by car is given by

ML Aggarwal Solutions for Class 8 Maths
Chapter 18: Mensuration

$$\begin{aligned} &= \frac{40 \times 28 \times 25}{1000} \times 13.5 \text{ km} \\ &= \frac{(40 \times 25) \times 28}{1000} \times \frac{135}{10} \text{ km} \\ &= \frac{1 \times 28}{1} \times \frac{135}{10} \text{ km} = \frac{14 \times 135}{5} \text{ km} \\ &= 14 \times 27 \text{ km} \\ &= 378 \text{ km} \end{aligned}$$

Hence, the car can travel 378 km with a full tank of petrol.

17. The diameter of a garden roller is 1.4 m and it is 2 m long. How much area it will cover in 5 revolutions?

Solution:

Given,

Diameter of a garden roller = 1.4 m

So, its radius (r) = $1.4/2 = 0.7 \text{ m} = 70 \text{ cm}$

and length (h) = 2m

Now, Curved surface area = $2\pi rh$

$$= 2 \times \frac{22}{7} \times 70 \times 200 \text{ cm}^2$$

$$= 88000 \text{ cm}^2$$

Hence, area covered in 5 revolutions = $(88000 \times 5)/10000 \text{ m}^2 = 44 \text{ m}^2$

18. The capacity of an open cylindrical tank is 2079 m^3 and the diameter of its base is 21m. Find the cost of plastering its inner surface at ₹40 per square metre.

Solution:

Given, capacity of an open cylindrical tank = 2079 m^3

Diameter of base = 21 m

So, radius (r) = $21/2 \text{ m}$

Let h be the height, then we have

$$\pi r^2 h = 2079$$

$$\frac{22}{7} \times \frac{21}{2} \times \frac{21}{2} \times h = 2079$$

$$h = \frac{(2079 \times 2)}{(11 \times 3 \times 21)} = 6 \text{ m}$$

Now,

$$\text{Curved Surface Area} + \text{Base area} = 2\pi rh + \pi r^2$$

$$= 2 \times \frac{22}{7} \times \frac{7}{2} \times 6 + \frac{22}{7} \times \frac{21}{2} \times \frac{21}{2} \text{ m}^2$$

$$= 396 + \frac{693}{2} = 396 + 346.5 = 742.5$$

Hence, the cost of plastering the surface = ₹40 × 742.5 = ₹29700

19. A solid right circular cylinder of height 1.21 m and diameter 28 cm is melted and recast into 7 equal solid cubes. Find the edge of each cube.

Solution:

Given,

Height of solid right circular cylinder = 1.21 m = 121 cm
and diameter = 28 cm

So, radius (r) = 28/2 = 14 cm

Now,

$$\begin{aligned} \text{Volume of the metal used} &= \pi r^2 h \\ &= \frac{22}{7} \times 14 \times 14 \times 121 \text{ cm}^3 \\ &= 74536 \text{ cm}^3 \end{aligned}$$

Thus, the volume of 7 solid cubes = 74536 cm³

And, volume of 1 cube = 74536/7 = 10648 cm³

Edge of the cube = $\sqrt[3]{10648}$

$$\begin{array}{r|l} 2 & 10648 \\ \hline 2 & 5324 \\ 2 & 2662 \\ 11 & 1331 \\ 11 & 121 \\ 11 & 11 \\ \hline & 1 \end{array}$$

$$= \sqrt[3]{2 \times 2 \times 2 \times 11 \times 11 \times 11}$$

$$= 2 \times 11 = 22 \text{ cm}$$

Hence, the edge of each cube is 22 cm.

20. (i) How many cubic metres of soil must be dug out to make a well 20 m deep and 2 m in diameter?

(ii) If the inner curved surface of the well in part (i) above is to be plastered at the rate of ₹50 per m², find the cost of plastering.

Solution:

(i) Given,

Depth of a well (h) = 20 m

and diameter = 2 m

Radius (r) = 2/2 = 1 m

$$\begin{aligned} \text{Volume of earth dug out} &= \pi r^2 h \\ &= \frac{22}{7} \times 1 \times 1 \times 20 \\ &= \frac{440}{7} \text{ m}^3 \end{aligned}$$

$$\begin{aligned} \text{(ii) Inner curved surface area} &= 2\pi r h \\ &= 2 \times \frac{22}{7} \times 1 \times 20 \\ &= \frac{880}{7} \text{ m}^2 \end{aligned}$$

The cost of plastering at the rate of ₹50 per $\text{m}^2 = ₹ 880/7 \times 50$
 $= ₹ 44000/7$
 $= ₹ 6285.70$

