

EXERCISE 15.1

1. Using the given information, find the value of x in each of the following figures:

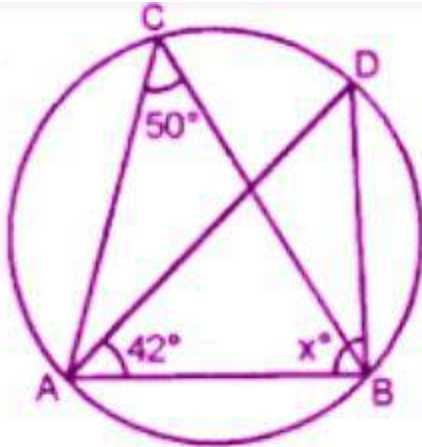

(i)

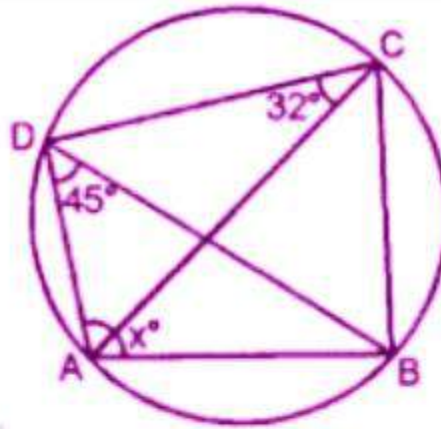

(ii)

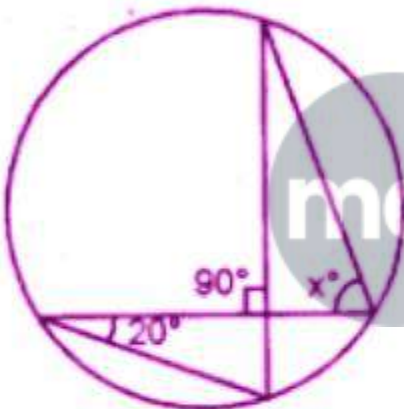

(iii)

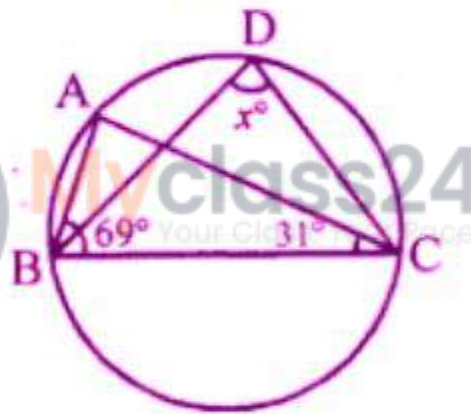

(iv)

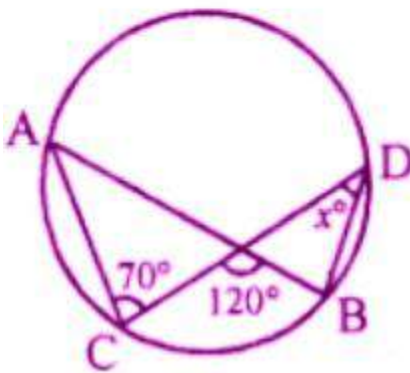

(v)

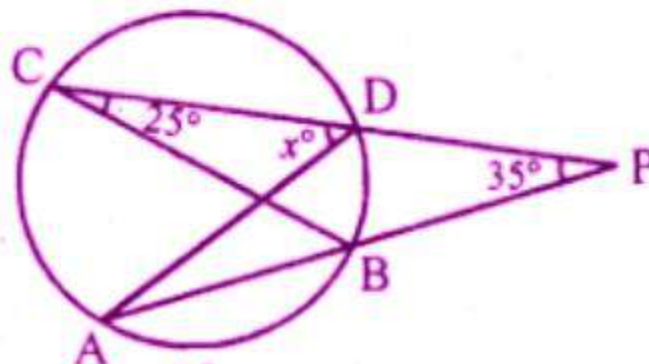

(vi)

Solution:

(i) $\angle ADB$ and $\angle ACB$ are in the same segment.

$$\angle ADB = \angle ACB = 50^\circ$$

Now in $\triangle ADB$,

$$\angle DAB + x + \angle ADB = 180^\circ$$

$$= 42^\circ + x + 50^\circ = 180^\circ$$

$$= 92^\circ + x = 180^\circ$$

$$x = 180^\circ - 92^\circ$$

$$x = 88^\circ$$

(ii) In the given figure we have

$$= 32^\circ + 45^\circ + x = 180^\circ$$

$$= 77^\circ + x = 180^\circ$$

$$x = 103^\circ$$

(iii) From the given number we have

$$\angle BAD = \angle BCD$$

Because angles in the same segment

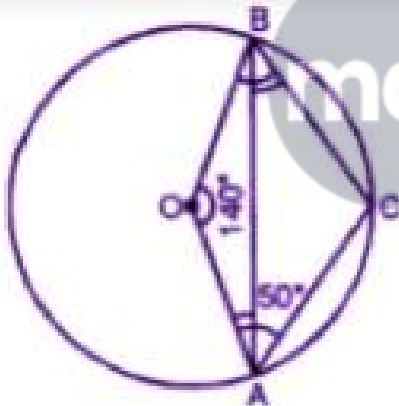

But $\angle BAD = 20^\circ$

$$\angle BAD = 20^\circ$$

$$\angle BCD = 20^\circ$$

$$\angle CEA = 90^\circ$$

$$\angle CED = 90^\circ$$

Now in triangle CED,

$$\angle CED + \angle BCD + \angle CDE = 180^\circ$$

$$90^\circ + 20^\circ + x = 180^\circ$$

$$= 110^\circ + x = 180^\circ$$

$$x = 180^\circ - 110^\circ$$

$$x = 70^\circ$$

(iv) In $\triangle ABC$

$$\angle ABC + \angle ABC + \angle BAC = 180^\circ$$

(Because sum of a triangle)

$$69^\circ + 31^\circ + \angle BAC = 180^\circ$$

$$\angle BAC = 180^\circ - 100^\circ$$

$$\angle BAC = 80^\circ$$

Since $\angle BAC$ and $\angle BAD$ are in the same
Segment.

$$\angle BAD = x^\circ = 80^\circ$$

(v) Given $\angle CPB = 120^\circ$, $\angle ACP = 70^\circ$

To find, x° i.e., $\angle PBD$

$$\text{Reflex } \angle CPB = \angle BPO + \angle CPA$$

$$120^\circ = \angle BPD + \angle BPD$$

(BPD = CPA are vertically opposite \angle s)

$$2\angle BPD = 120^\circ \quad \angle PBD = 120^\circ/2 = 60^\circ$$

Also $\angle ACP$ and $\angle PBD$ are in the same segment

$$\angle PBD + \angle ACP = 70^\circ$$

Now, In $\triangle PBD$

$$\angle PBD + \angle PDB + \angle BPD = 180^\circ$$

(sum of all \angle s in a triangle)

$$70^\circ + x^\circ + 60^\circ = 180^\circ$$

$$x = 180^\circ - 130^\circ$$

$$x = 50^\circ$$

(vi) $\angle DAB = \angle BCD$

(Angles in the same segment of the circle)

$$\angle DAB = 25^\circ \quad (\angle BCD = 25^\circ \text{ given})$$

In $\triangle DAP$,

$$\text{Ex, } \angle CDA = \angle DAP + \angle DPA$$

$$x^\circ = \angle DAB + \angle DPA$$

$$x^\circ = 25^\circ + 35^\circ$$

$$x^\circ = 60^\circ$$

2. If O is the center of the circle, find the value of x in each of the following figures

(using the given information):

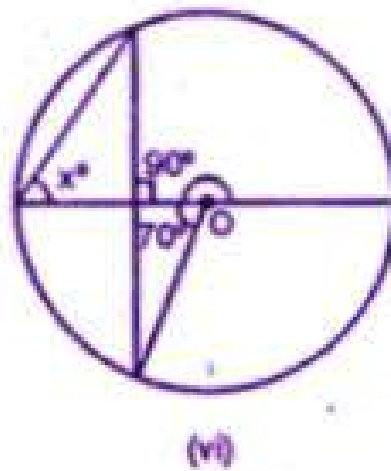
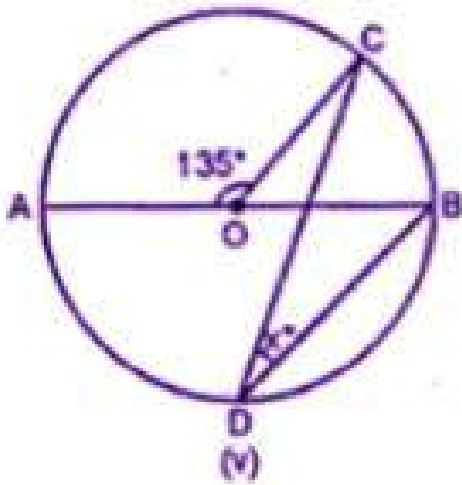
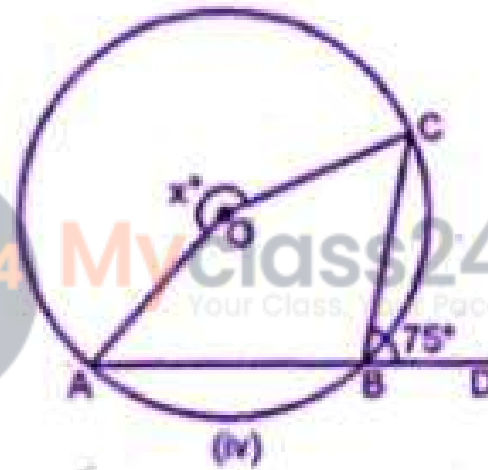
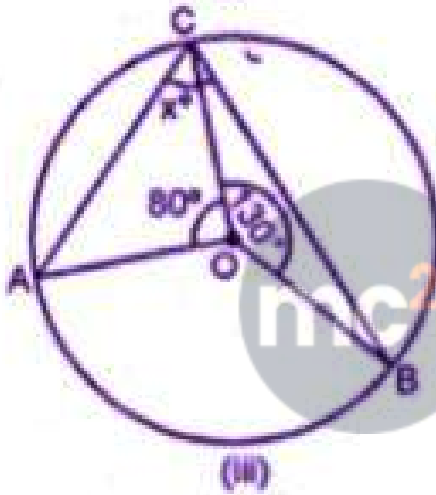
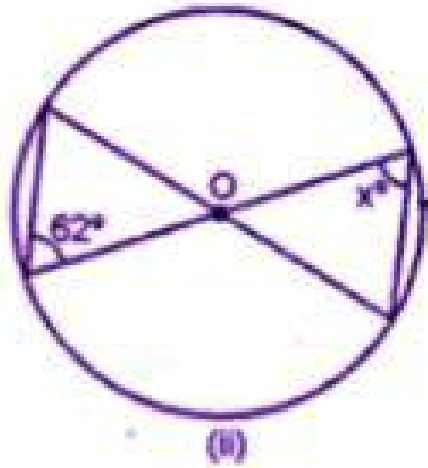
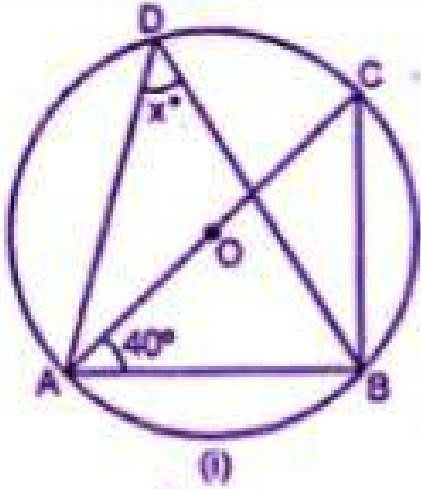

Solution:

(i) $\angle ACB = \angle ADB$

(Angles in the same segment of a circle)

But $\angle ADB = x^\circ$

$\angle ABC = x^\circ$

Now in $\triangle ABC$

$\angle CAB + \angle ABC + \angle ACB = 180^\circ$

$40^\circ + 90^\circ + x^\circ = 180^\circ$

(AC is the diameter)

$130^\circ + x^\circ = 180^\circ$

$x^\circ = 180^\circ - 130^\circ = 50^\circ$

(ii) $\angle ACD = \angle ABD$

(angles in the same segment)

$\angle ACD = x^\circ$

Now in triangle OAC,

$OA = OC$

(radii of the same circle)

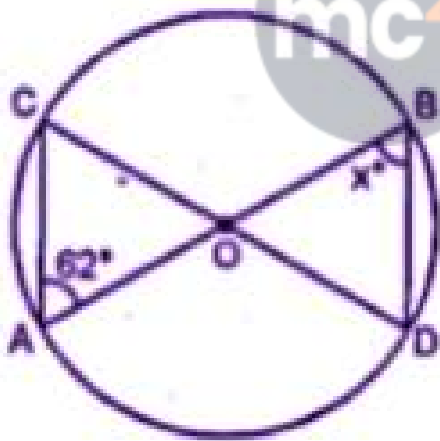

$\angle ACO = \angle AOC$

(opposite angles of equal sides)

Therefore, $x^\circ = 62^\circ$

(iii) $\angle AOB + \angle AOC + \angle BOC = 360^\circ$

(sum of angles at a point)

$\angle AOB + 80^\circ + 130^\circ = 360^\circ$

$\angle AOB + 210^\circ = 360^\circ$

$\angle AOB = 360^\circ - 210^\circ = 150^\circ$

Now arc AB subtends $\angle AOB$ at the centre $\angle ACB$ at the remaining part of the circle

$$\angle AOB = 2 \angle ACB$$

$$\angle ACB = \frac{1}{2} \angle AOB = \frac{1}{2} \times 150^\circ = 75^\circ$$

$$(iv) \angle ACB + \angle CBD = 180^\circ$$

$$\angle ABC + 75^\circ = 180^\circ$$

$$\angle ABC = 180^\circ - 75^\circ = 105^\circ$$

Now arc AC Subtends reflex $\angle AOC$ at the centre and $\angle ABC$ at the remaining part of the circle.

$$\text{Reflex } \angle AOC = 2 \angle ABC$$

$$= 2 \times 105^\circ = 210^\circ$$

$$(v) \angle AOC + \angle COB = 180^\circ$$

$$135^\circ + \angle COB = 180^\circ$$

$$\angle COB = 180^\circ - 135^\circ = 45^\circ$$

Now arc BC Subtends reflex $\angle COB$ at the centre and $\angle CDB$ at the remaining part of the circle.

$$\angle COB = 2 \angle CDB$$

$$\angle CDB = \frac{1}{2} \angle COB$$

$$= \frac{1}{2} \times 45^\circ = 45^\circ/2 = 22 \frac{1}{2}^\circ$$

(vi) Arc AB subtends $\angle AOD$ at the centre and $\angle ACD$ at the remaining part of the Circle

$$\angle AOD = 2 \angle ACB$$

$$\angle ACB = \frac{1}{2} \angle AOD = \frac{1}{2} \times 70^\circ = 35^\circ$$

$$\angle CMO = 90^\circ$$

$$\angle AMC = 90^\circ$$

$$(\angle AMC + \angle CMO = 180^\circ)$$



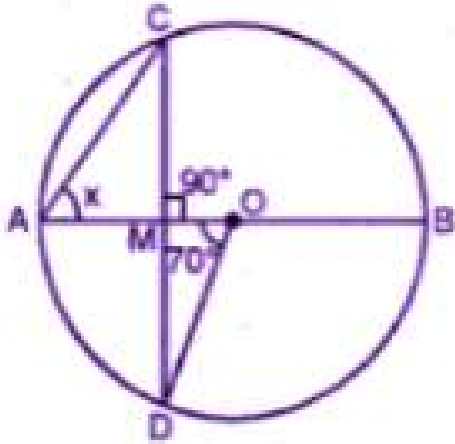

Now in $\triangle ACM$

$$\angle ACM + \angle AMC + \angle CAM = 180^\circ$$

$$35^\circ + 90^\circ + x^\circ = 180^\circ$$

$$125^\circ + x^\circ = 180^\circ$$

$$x^\circ = 180 - 125^\circ = 55^\circ$$

3. (a) In the figure (i) given below, $AD \parallel BC$. If $\angle ACB = 35^\circ$. Find the measurement of $\angle DBC$.

(b) In the figure (ii) given below, it is given that O is the centre of the circle and $\angle AOC = 130^\circ$. Find $\angle ABC$

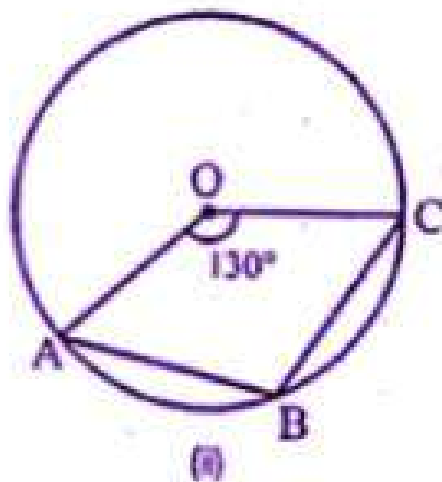
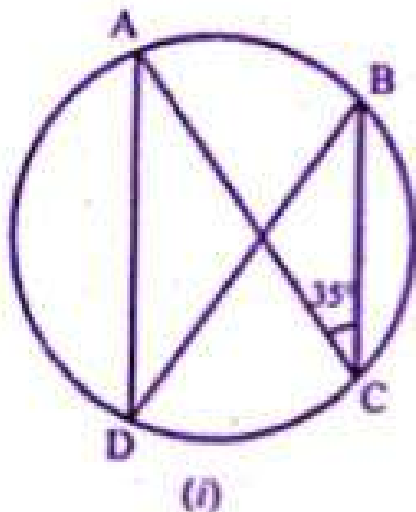

Solution:

(a) Construction: Join AB

$$\angle A = \angle C = 35^\circ \text{ (Alt Angles)}$$

$$\angle ABC = 35^\circ$$

$$(b) \angle AOC + \text{reflex } \angle AOC = 360^\circ$$

$$130^\circ + \text{Reflex } \angle AOC = 360^\circ$$

$$\text{Reflex } \angle AOC = 360^\circ - 130^\circ = 230^\circ$$

Now arc BC subtends reflex $\angle AOC$ at the centre and $\angle ABC$ at the remaining part of the circle.

$$\text{Reflex } \angle AOC = 2 \angle ABC$$

$$\angle ABC = \frac{1}{2} \text{ reflex } \angle AOC$$

$$= \frac{1}{2} \times 230^\circ = 115^\circ$$

4. a) In the figure (i) given below, calculate the values of x and y .

(b) In the figure (ii) given below, O is the centre of the circle. Calculate the values of x and y .

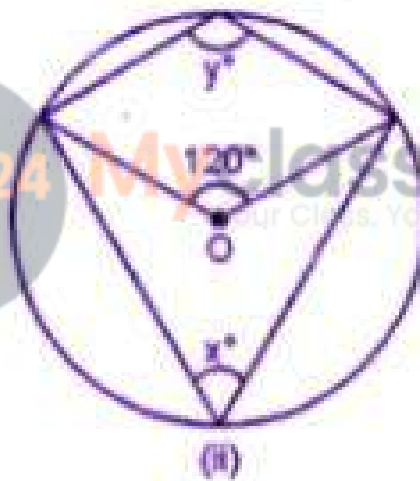
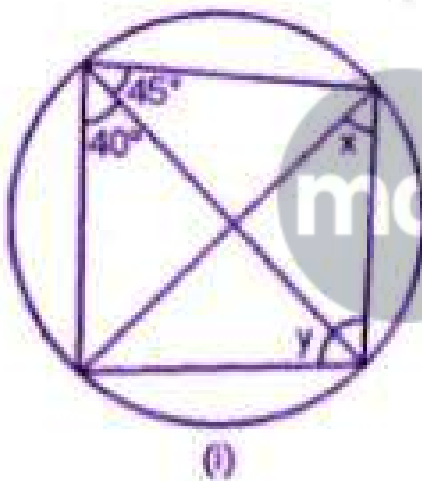

Solution:

(a) ABCD is cyclic Quadrilateral

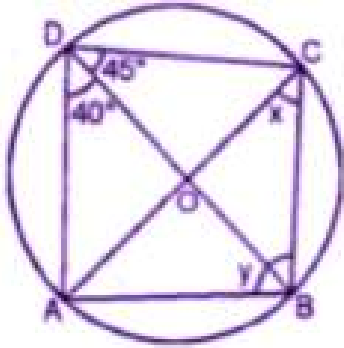

$$\angle B + \angle D = 180^\circ$$

$$y + 40^\circ + 45^\circ = 180^\circ$$

$$(y + 85^\circ = 180^\circ)$$

$$y = 180^\circ - 85^\circ = 95^\circ$$

$$\angle ACB = \angle ADB$$

$$x^\circ = 40$$

(a) Arc ADC subtends $\angle AOC$ at the centre and $\angle ABC$ at the remaining part of the circle

$$\angle AOC = 2 \angle ABC$$

$$x^\circ = 60^\circ$$

Again ABCD is a cyclic quadrilateral

$$\angle B + \angle D = 180^\circ$$

$$(60^\circ + y^\circ = 180^\circ)$$

$$y = 180^\circ - 60^\circ = 120^\circ$$

5. (a) In the figure (i) given below, M, A, B, N are points on a circle having centre O. AN and MB cut at Y. If $\angle NYB = 50^\circ$ and $\angle YNB = 20^\circ$, find $\angle MAN$ and the reflex angle MON.

(b) In the figure (ii) given below, O is the centre of the circle. If $\angle AOB = 140^\circ$ and $\angle OAC = 50^\circ$, find

(i) $\angle ACB$

(ii) $\angle OBC$

(iii) $\angle OAB$

(iv) $\angle CBA$

Solution

(a) $\angle NYB = 50^\circ$, $\angle YNB = 20^\circ$.

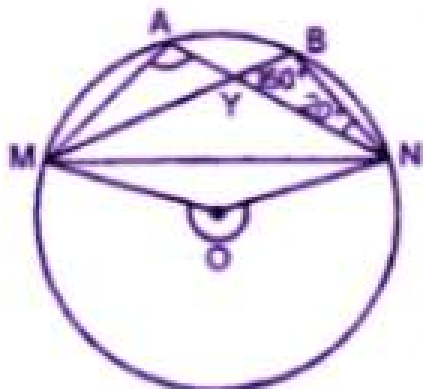

In $\triangle YNB$,

$$\angle NYB + \angle YNB + \angle YBN = 180^\circ$$

$$50^\circ + 20^\circ + \angle YBN = 180^\circ$$

$$\angle YBN + 70^\circ = 180^\circ$$

$$\angle YBN = 180^\circ - 70^\circ = 110^\circ$$

But $\angle MAN = \angle YBN$

(Angles in the same segment)

$$\angle MAN = 110^\circ$$

Major arc MN subtend reflex $\angle MON$ at the Centre and $\angle MAN$ at the remaining part of the circle.

Reflex $\angle MAN$ at the remaining part of the circle

$$\text{Reflex } \angle MON = 2 \angle MAN = 2 \times 110^\circ = 220^\circ$$

$$(b) (i) \angle AOB + \text{reflex } \angle AOB = 360^\circ$$

(Angles at the point)

$$140^\circ + \text{reflex } \angle AOB = 360^\circ$$

$$\text{Reflex } \angle AOB = 360^\circ - 140^\circ = 220^\circ$$

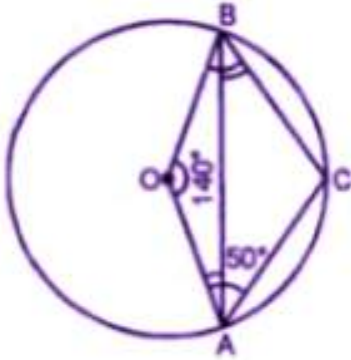

Now major arc AB subtends $\angle AOB + \angle OBC = 360^\circ$

$$50^\circ + 110^\circ + 140^\circ + \angle OBC = 360^\circ$$

$$300^\circ + \angle OBC = 360^\circ$$

$$\angle 300^\circ + \angle OBC = 360^\circ$$

$$\angle OBC = 360^\circ - 300^\circ$$

$$\angle OBC = 60^\circ$$

(ii) In Quadrilateral .OACB

$$\angle OAC + \angle ACB + \angle AOB + \angle OBC = 360^\circ$$

$$50^\circ + 110^\circ + 140^\circ + \angle OBC = 360^\circ$$

$$300^\circ + \angle OBC = 360^\circ$$

$$\angle OBC = 360^\circ - 300^\circ$$

$$\angle OBC = 60^\circ$$

(iii) in ΔOAB ,

$$OA = OB$$

(Radii of the same circle)

$$\angle OAB + \angle OBA = 180^\circ$$

$$2 \angle OAB = 180^\circ - 140^\circ = 40^\circ$$

$$\angle OAB = 40^\circ / 2 = 20^\circ$$

$$\text{But } \angle OBC = 60^\circ$$

$$\angle CBA = \angle OBC - \angle OBA$$

$$= 60^\circ - 20^\circ = 40^\circ$$

6. (a) In the figure (i) given below, O is the centre of the circle and $\angle PBA = 42^\circ$.

Calculate the value of $\angle PQB$

(b) In the figure (ii) given below, AB is a diameter of the circle whose centre is O. Given that $\angle ECD = \angle EDC = 32^\circ$, calculate

(i) $\angle CEF$

(ii) $\angle COF$.

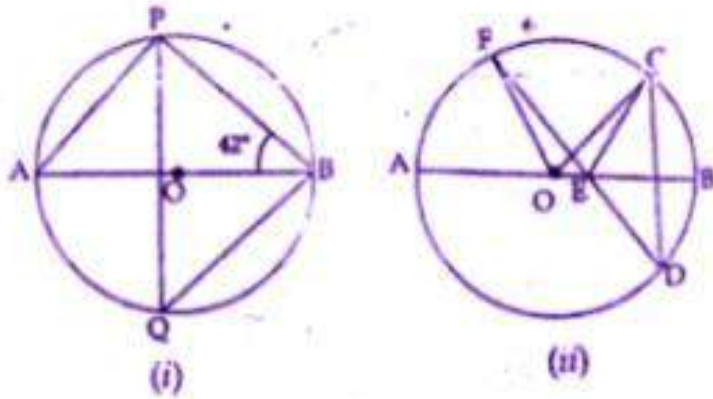

Solution:

In $\triangle APB$,

$\angle APB = 90^\circ$ (Angle in a semi-circle)

But $\angle A + \angle APB + \angle ABP = 180^\circ$ (Angles of a triangle)

$\angle A + 90^\circ + 42^\circ = 180^\circ$

$\angle A + 132^\circ = 180^\circ$

$\Rightarrow \angle A = 180^\circ - 132^\circ = 48^\circ$

But $\angle A = \angle PQB$

(Angles in the same segment of a circle)

$\angle PQB = 48^\circ$

(b) (i) in $\triangle EDC$,

(Ext, angle of a triangle is equal to the sum of its interior opposite angles)

(ii) arc CF subtends $\angle COF$ at the centre and

$\angle CDF$ at the remaining part of the circle

$\angle COF = 2 \angle CDF = 2 \angle CDE$

$= 2 \times 32^\circ = 2 \angle CDE$

$= 2 \times 32^\circ = 64^\circ$

7. (a) In the figure (i) given below, AB is a diameter of the circle APBR. APQ and RBQ are straight lines, $\angle A = 35^\circ$, $\angle Q = 25^\circ$. Find (i) $\angle PRB$ (ii) $\angle PBR$ (iii) $\angle BPR$.

(b) In the figure (ii) given below, it is given that $\angle ABC = 40^\circ$ and AD is a diameter of the circle. Calculate $\angle DAC$.

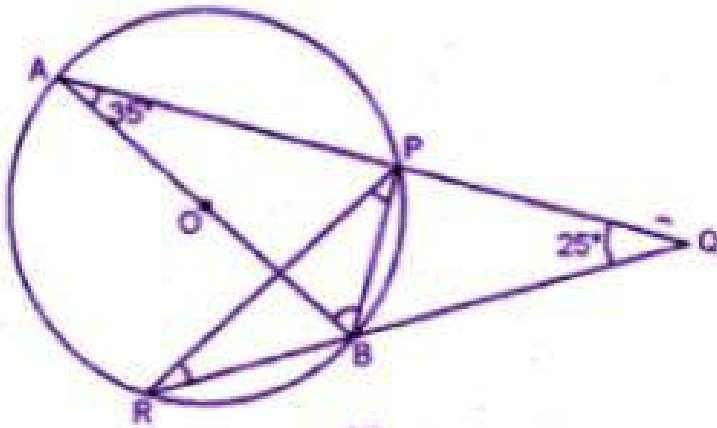

(i)



(ii)

Solution

(a) (i) $\angle PRB = \angle BAP$

(Angles in the same segment of the circle)

$\therefore \angle PRB = 35^\circ$ ($\because \angle BAP = 35^\circ$ given)

8. (a) In the figure given below, P and Q are centers of two circles intersecting at B and C. ACD is a straight line. Calculate the numerical value of x.

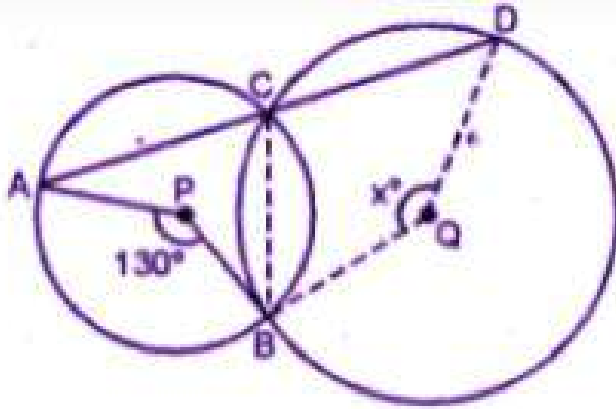

(b) In the figure given below, O is the circumcenter of triangle ABC in which $AC = BC$.

Given that $\angle ACB = 56^\circ$, calculate

(i) $\angle CAB$

(ii) $\angle OAC$

Solution:

Given that

(a) Arc AB subtends $\angle APB$ at the center and $\angle ACB$ at the remaining part of the circle

$$\angle ACB = \frac{1}{2} \angle APB = \frac{1}{2} \times 130^\circ = 65^\circ$$

$$\text{But } \angle ACB + \angle BCD = 180^\circ$$

(Linear Pair)

$$65^\circ + \angle BCD = 180^\circ$$

$$\angle BCD = 180^\circ - 65^\circ = 115^\circ$$

Major arc BD subtends reflex $\angle BQD$ at the Centre and $\angle BCD$ at the remaining part of the circle

$$\text{reflex } \angle BQD = 2 \angle BCD$$

$$= 2 \times 115^\circ = 230^\circ$$

$$\text{But reflex } \angle BQD + x = 360^\circ$$

(Angles at a point)

$$230^\circ + x = 360^\circ$$

$$x = 360^\circ - 230^\circ = 130^\circ$$

(b) Join OC

In $\triangle ABC$, $AC = BC$

$$\angle A = \angle B$$

$$\text{But } \angle A + \angle B + \angle C = 180^\circ$$

$$\angle A + \angle A + 56^\circ = 180^\circ$$

$$2 \angle A = 180^\circ - 56^\circ = 124^\circ$$

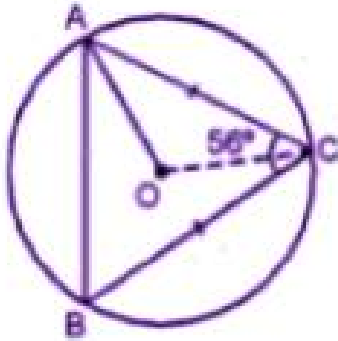

$$\angle A = 124/2 = 62^\circ \text{ or } \angle CAB = 62^\circ$$

OC is the radius of the circle

OC bisects $\angle ACB$

$$\angle OCA = \frac{1}{2} \angle ACB = \frac{1}{2} \times 56^\circ = 28^\circ$$

Now in $\triangle OAC$

$$OA = OC$$

(radii of the same Circle)

$$\angle OAC = \angle OCA = 28^\circ$$



EXERCISE 15.2

1. If O is the center of the circle, find the value of x in each of the following figures (using the given information)

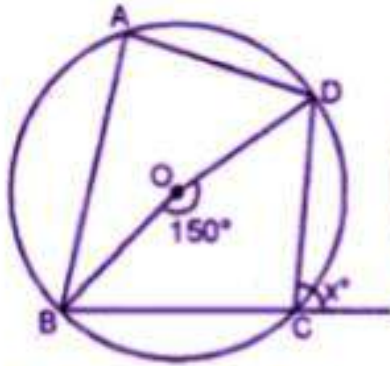

(i)

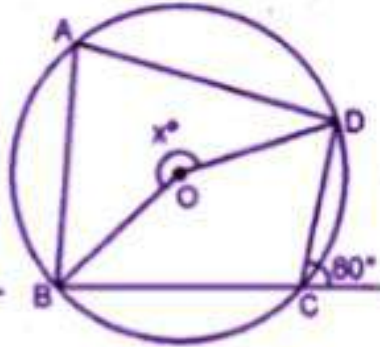

(ii)

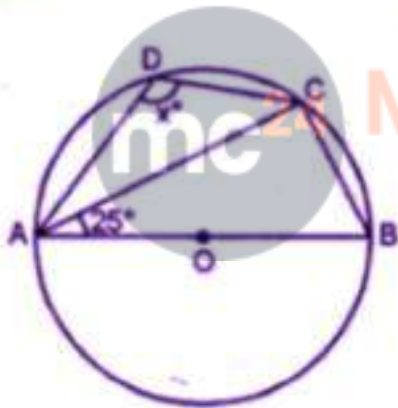

(iii)

Solution:

From the figure

(i) $ABCD$ is a cyclic quadrilateral

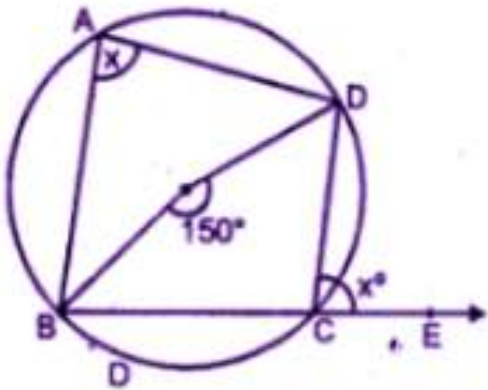

Ext. $\angle DCE = \angle BAD$

$$\angle BAD = x^\circ$$

Now arc BD subtends $\angle BOD$ at the center

And $\angle BAD$ at the remaining part of the circle.

$$\angle BOD = 2 \angle BAD = 2x$$

$$2x = 150^\circ \quad (x = 75^\circ)$$

(ii) $\angle BCD + \angle DCE = 180^\circ$

(Linear pair)

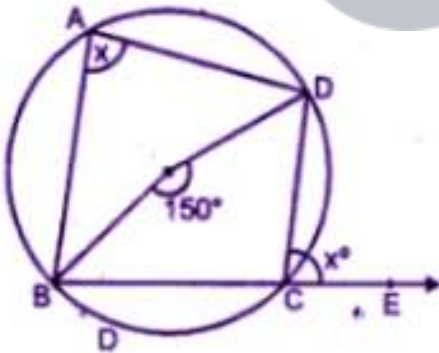

$$\angle BCD + 80^\circ = 180^\circ$$

$$\angle BCD = 180^\circ - 80^\circ = 100^\circ$$

Arc BAD subtends reflex $\angle BOD$ at the

Centre and $\angle BCD$ at the remaining part of the circle

$$\text{Reflex } \angle BOD = 2 \angle BCD$$

$$x^\circ = 2 \times 100^\circ = 200^\circ$$

(iii) In $\triangle ACB$,

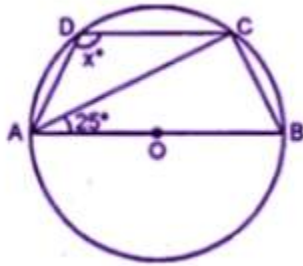

$$\angle CAB + \angle ABC + \angle ACB = 180^\circ$$

(Angles of a triangle)

$$\text{But } \angle ACB = 90^\circ$$

((Angles of a semicircle)

$$25^\circ + 90^\circ + \angle ABC = 180^\circ$$

$$= 115^\circ + \angle ABC = 180^\circ$$

$$\angle ABC = 180^\circ - 115^\circ = 65^\circ$$

ABCD is a cyclic quadrilateral

$$\angle ABC + \angle ADC = 180^\circ$$

(Opposite angles of a cyclic quadrilateral)

$$65^\circ + x^\circ = 180^\circ$$

$$x^\circ = 180^\circ - 65^\circ = 115^\circ$$

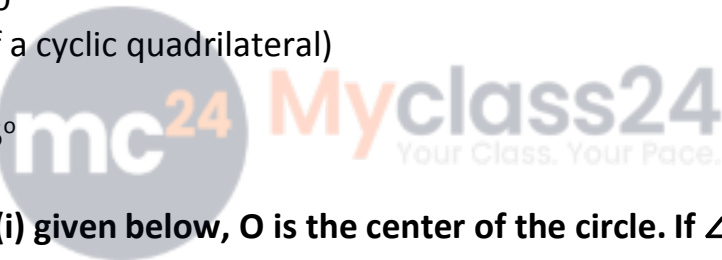

2. (a) In the figure (i) given below, O is the center of the circle. If $\angle AOC = 150^\circ$, find (i) $\angle ABC$ (ii) $\angle ADC$

(b) In the figure (i) given below, AC is a diameter of the given circle and $\angle BCD = 75^\circ$. Calculate the size of (i) $\angle ABC$ (ii) $\angle EAF$.

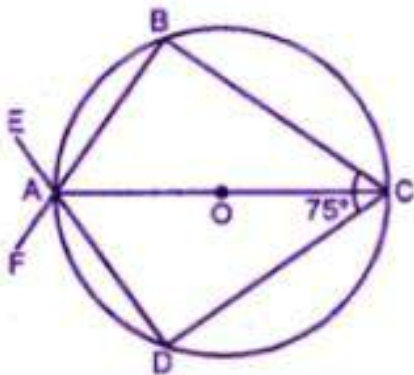

Solution:

(a) Given, $\angle AOC = 150^\circ$ and $AD = CD$

We know that an angle subtends by an arc of a circle at the center is twice the angle subtended by the same arc at any point on the remaining part of the circle.

(i) $\angle AOC = 2 \times \angle ABC$

$\angle ABC = \angle AOC/2 = 150^\circ/2 = 75^\circ$

(ii) From the figure, ABCD is a cyclic quadrilateral

$\angle ABC + \angle ADC = 180^\circ$

(Sum of opposite angles in a cyclic quadrilateral is 180°)

$75^\circ + \angle ADC = 180^\circ$

$\angle ADC + 180^\circ - 75^\circ$

$\angle ADC = 105^\circ$

(b) (i) AC is the diameter of the circle

$\angle ABC = 90^\circ$ (Angle in a semi-circle)

(ii) ABCD is a cyclic quadrilateral

$\angle BAD + \angle BCD = 180^\circ$

$\angle BAD + 75^\circ = 180^\circ$

($\angle BCD = 75^\circ$)

$\angle BAD = 180^\circ - 75^\circ = 105^\circ$

But $\angle EAF = \angle BAD$

(Vertically opposite angles)

$\angle EAF = 105^\circ$

3. (a) In the figure, (i) given below, if $\angle DBC = 58^\circ$ and BD is a diameter of the circle, calculate:

(i) $\angle BDC$ (ii) $\angle BEC$ (iii) $\angle BAC$

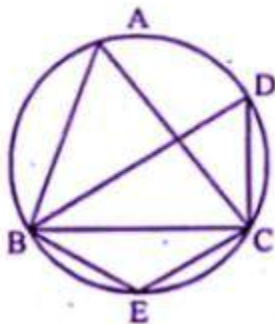

(b) In the figure (if) given below, AB is parallel to DC, $\angle BCE = 80^\circ$ and $\angle BAC = 25^\circ$. Find:
 (i) $\angle CAD$ (ii) $\angle CBD$ (iii) $\angle ADC$ (2008)

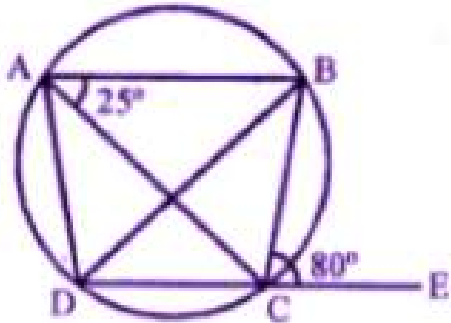

Solution:

(a) $\angle DBC = 58^\circ$

BD is diameter

$\angle DCB = 90^\circ$ (Angle in semi-circle)

(i) In $\triangle BDC$

$\angle BDC + \angle DCB + \angle CBD = 180^\circ$

$\angle BDC = 180^\circ - 90^\circ - 58^\circ = 32^\circ$

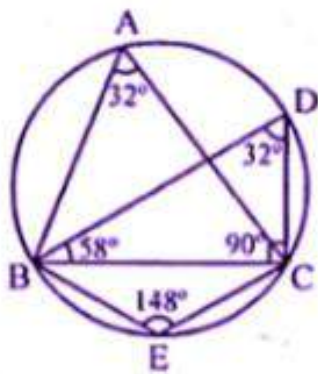

(ii) $\angle BEC = 180^\circ - 32^\circ = 148^\circ$

(opposite angles of cyclic quadrilateral)

(iii) $\angle BAC = \angle BDC = 32^\circ$

(Angles in same segment)

(b) in the figure, $AB \parallel DC$
 $\angle BCE = 80^\circ$ and $\angle BAC = 25^\circ$
 ABCD is a cyclic Quadrilateral and DC is Production to E

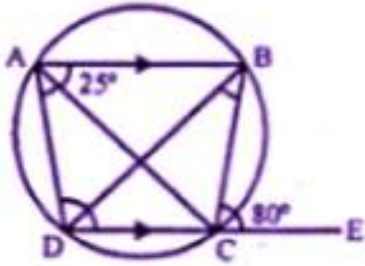

(i) Ext, $\angle BCE =$ interior $\angle A$
 $80^\circ = \angle BAC + \angle CAD$
 $80^\circ = 25^\circ + \angle CAD$
 $\angle CAD = 80^\circ - 25^\circ = 55^\circ$

(ii) But $\angle CAD = \angle CBD$
 (Alternate angles)
 $\angle CBD = 55^\circ$

(iii) $\angle BAC = \angle BDC$
 (Angles in the same segments)
 $\angle BDC = 25^\circ$
 ($\angle BAC = 25^\circ$)
 Now $AB \parallel DC$ and BD is the transversal
 $\angle BDC = \angle ABD$
 $\angle ABD = 25^\circ$
 $\angle ABC = \angle ABD + \angle CBD = 25^\circ + 55^\circ = 80^\circ$
 But $\angle ABC + \angle ADC = 180^\circ$
 (opposite angles of a cyclic quadrilateral)
 $80^\circ + \angle ADC = 180^\circ$
 $\angle ADC = 180^\circ - 80^\circ = 100^\circ$

4. (a) In the figure given below, ABCD is a cyclic quadrilateral. If $\angle ADC = 80^\circ$ and $\angle ACD = 52^\circ$, find the values of $\angle ABC$ and $\angle CBD$.

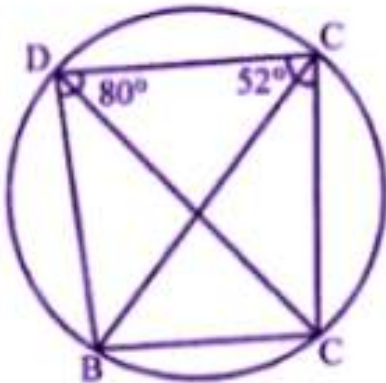

(b) In the figure given below, O is the center of the circle. $\angle AOE = 150^\circ$, $\angle DAO = 51^\circ$. Calculate the sizes of $\angle BEC$ and $\angle EBC$.

Solution:

(a) In the given figure, ABCD is a cyclic quadrilateral

$\angle ADC = 80^\circ$ and $\angle ACD = 52^\circ$

To find the measure of $\angle ABC$ and $\angle CBD$

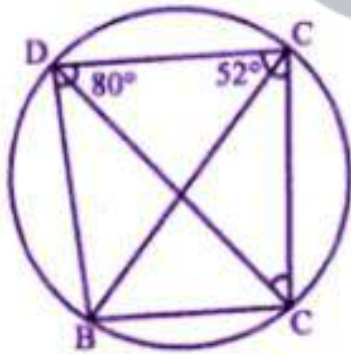

ABCD is a Cyclic Quadrilateral

$$\angle ABC + \angle ADC = 180^\circ$$

(Sum of opposite angles = 180°)

$$\angle ABC + 80^\circ = 180^\circ$$

$$\angle AOE = 150^\circ, \angle DAO = 51^\circ$$

To find $\angle BEC$ and $\angle EBC$

ABED is a cyclic quadrilateral

$$\text{Ext. } \angle BEC = \angle DAB = 51^\circ$$

$$\angle AOE = 150^\circ$$

$$\text{Ref } \angle AOE = 360^\circ - 150^\circ = 210^\circ$$

$$\angle AOE = 150^\circ$$

$$\text{Ref } \angle AOE = 360^\circ - 150^\circ = 210^\circ$$

Now arc ABE subtends $\angle AOE$ at the Centre

And $\angle ADE$ at the remaining part of the circle.

$$\angle ADE = \frac{1}{2} \text{ref } \angle AOE = \frac{1}{2} \times 210^\circ = 105^\circ$$

$$\text{But Ext } \angle EBC = \angle ADE = 105^\circ$$

$$\text{Hence } \angle BEC = 51^\circ \text{ and } \angle EBC = 105^\circ$$

5. (a) In the figure (i) given below, ABCD is a parallelogram. A circle passes through A and D and cuts AB at E and DC at F. Given that $\angle BEF = 80^\circ$, find $\angle ABC$.

(b) In the figure (ii) given below, ABCD is a cyclic trapezium in which AD is parallel to BC and $\angle B = 70^\circ$, find:

(i) $\angle BAD$ (ii) $\angle BCD$.

Solution:

(a) ADFE is a cyclic quadrilateral

$$\text{Ext. } \angle FEB = \angle ADF$$

$$\Rightarrow \angle ADF = 80^\circ$$

ABCD is a parallelogram

$$\angle B = \angle D = \angle ADF = 80^\circ$$

$$\text{or } \angle ABC = 80^\circ$$

(b) In trapezium ABCD, $AD \parallel BC$

$$(i) \angle B + \angle A = 180^\circ$$

$$\Rightarrow 70^\circ + \angle A = 180^\circ$$

$$\Rightarrow \angle A = 180^\circ - 70^\circ = 110^\circ$$

$$\angle BAD = 110^\circ$$

(ii) ABCD is a cyclic quadrilateral

$$\angle A + \angle C = 180^\circ$$

$$\Rightarrow 110^\circ + \angle C = 180^\circ$$

$$\Rightarrow \angle C = 180^\circ - 110^\circ = 70^\circ$$

$$\angle BCD = 70^\circ$$



6. (a) In the figure given below, O is the center of the circle. If $\angle BAD = 30^\circ$, find the values of p, q and r.

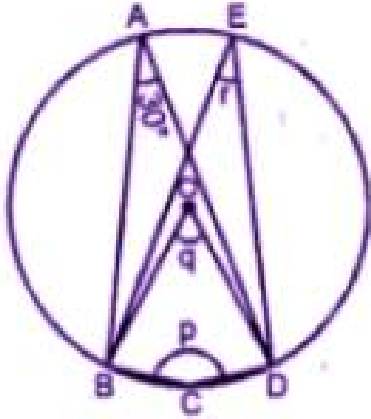

(a) In the figure given below, two circles intersect at points P and Q. If $\angle A = 80^\circ$ and $\angle D = 84^\circ$, calculate

- (i) $\angle QBC$
- (ii) $\angle BCP$

Solution:

(a) (i) ABCD is a cyclic quadrilateral

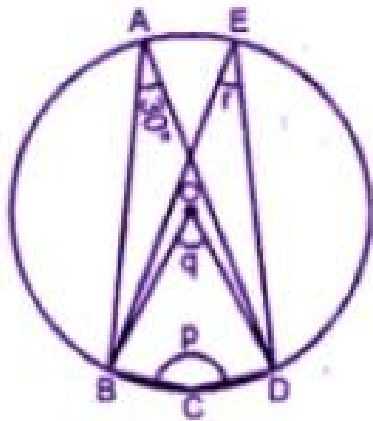

$$\angle A + \angle C = 180^\circ$$

$$30^\circ + p = 180^\circ$$

$$p = 180^\circ - 30^\circ = 150^\circ$$

(ii) Arc BD subtends $\angle BOD$ at the center
And $\angle BAD$ at the remaining part of the circle
 $\angle BOD = 2 \angle BAD$
 $q = 2 \times 30^\circ = 60^\circ$
 $\angle BAD = \angle BED$ are in the same segment of the circle
 $\angle BAD = \angle BED$
 $30^\circ = r$
 $r = 30^\circ$

(b) Join PQ
AQPD is a cyclic quadrilateral

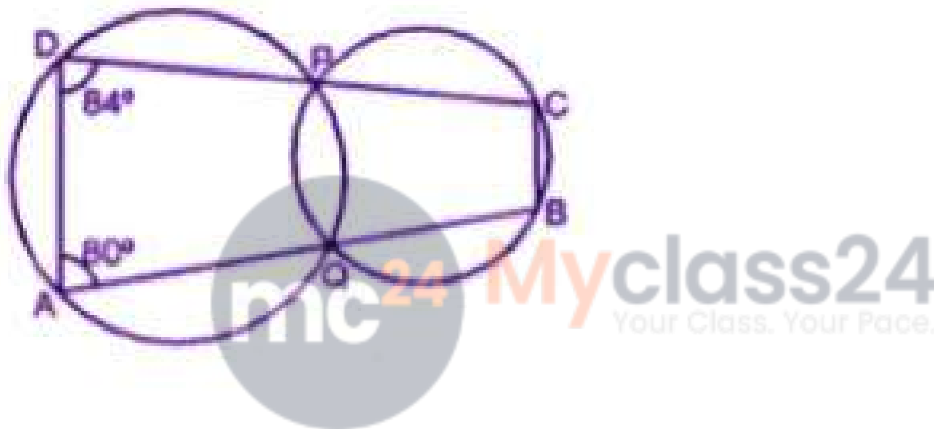

$$\angle A + \angle QPD = 180^\circ$$

7. (a) In the figure given below, PQ is a diameter. Chord SR is parallel to PQ. Given $\angle PQR = 58^\circ$, calculate (i) $\angle RPQ$ (ii) $\angle STP$
(T is a point on the minor arc SP)

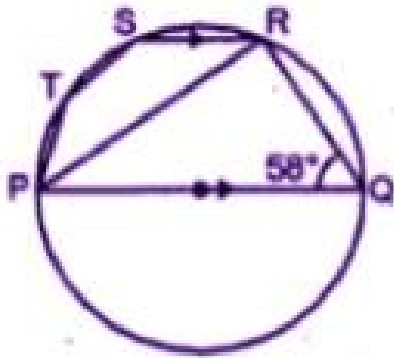

(b) In the figure given below, if $\angle ACE = 43^\circ$ and $\angle CAF = 62^\circ$, find the values of a, b and c (2007)

Solution:

(a) In ΔPQR ,

$\angle PRQ = 90^\circ$ (Angle in a semi-circle) and $\angle PQR = 58^\circ$

$\angle RPQ = 90^\circ - \angle PQR = 90^\circ - 58^\circ = 32^\circ$

$SR \parallel PQ$ (given)

$\angle SRP = \angle RPQ = 32^\circ$ (Alternate angles)

Now PRST is a cyclic quadrilateral,

$\angle STP + \angle SRP = 180^\circ$

$\angle STP = 180^\circ - 32^\circ = 148^\circ$

(b) In the given figure,

$\angle ACE = 43^\circ$ and $\angle CAF = 62^\circ$

Now, in ΔAEC

$\angle ACE + \angle CAE + \angle AEC = 180^\circ$

$43^\circ + 62^\circ + \angle AEC = 180^\circ$

$105^\circ + \angle AEC = 180^\circ$

$\angle AEC = 180^\circ - 105^\circ = 75^\circ$

But $\angle ABD + \angle AED = 180^\circ$

(sum of opposite angles of acyclic quadrilateral)

and $\angle AED = \angle AEC$

$a + 75^\circ = 180^\circ$

$a = 180^\circ - 75^\circ - 105^\circ$

but $\angle EDF = \angle BAE$

(Angles in the alternate segment)

8. (a) In the figure (i) given below, AB is a diameter of the circle. If $\angle ADC = 120^\circ$, find $\angle CAB$.

(b) In the figure (ii) given below, sides AB and DC of a cyclic quadrilateral ABCD are produced to meet at E, the sides AD and BC are produced to meet at F. If $x : y : z = 3 : 4 : 5$, find the values of x, y and z.

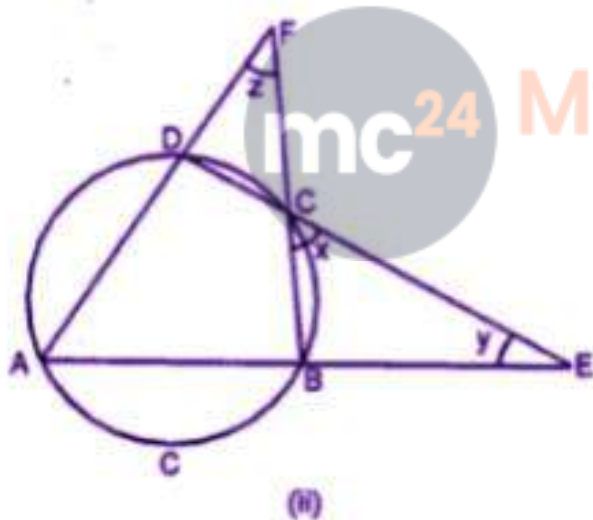
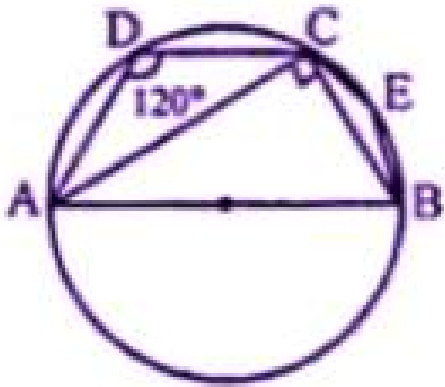

mc²⁴ Myclass24
Your Class. Your Pace.

Solution:

(a) Construction: Join BC, and AC then ABCD is a cyclic quadrilateral.

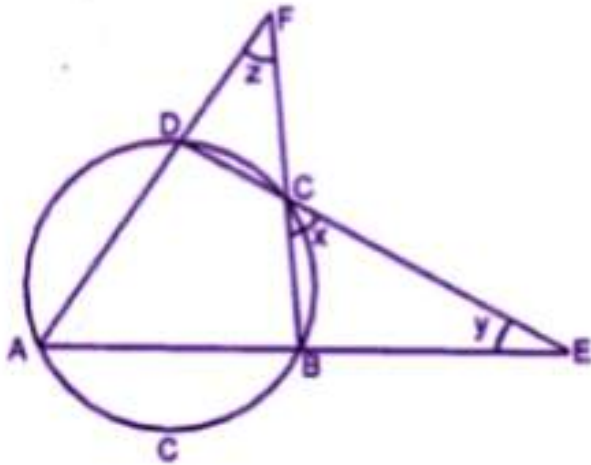

Now in $\triangle DCF$

Ext. $\angle 2 = x + z$

and in $\triangle CBE$

Ext. $\angle 1 = x + y$

Adding (i) and (ii)

$$x + y + x + z = \angle 1 + \angle 2$$

$$2x + y + z = 180^\circ$$

(ABCD is a cyclic quadrilateral)

But $x : y : z = 3 : 4 : 5$

$$x/y = 3/4 \quad (y = 4/3 x)$$

$$x/z = 3/5 \quad (z = 5/3 x)$$

Exercise 15.3

1. Find the length of the tangent drawn to a circle of radius 3cm, from a point distant 5cm from the center.

Solution:

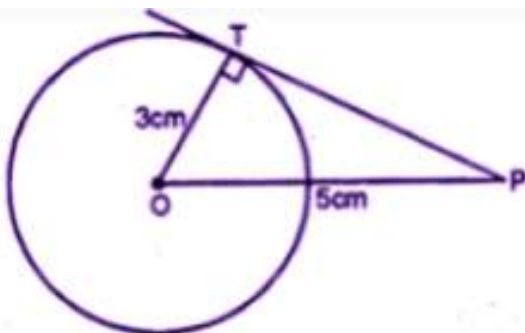

In a circle with center O and radius 3cm and p is at a distance of 5cm.

That is $OT = 3$ cm, $OP = 5$ cm

OT is the radius of the circle

$OT \perp PT$

Now in right ΔOTP , by Pythagoras axiom,

$$OP^2 = OT^2 + PT^2$$

$$(5)^2 = (3)^2 + PT^2$$

$$PT^2 = (5)^2 - (3)^2 = 25 - 9 = 16 = (4)^2$$

$$PT = 4 \text{ cm.}$$

2. A point P is at a distance 13 cm from the center C of a circle and PT is a tangent to the given circle. If $PT = 12$ cm, find the radius of the circle.

Solution:

CT is the radius

CP = 13 cm and tangent $PT = 12$ cm

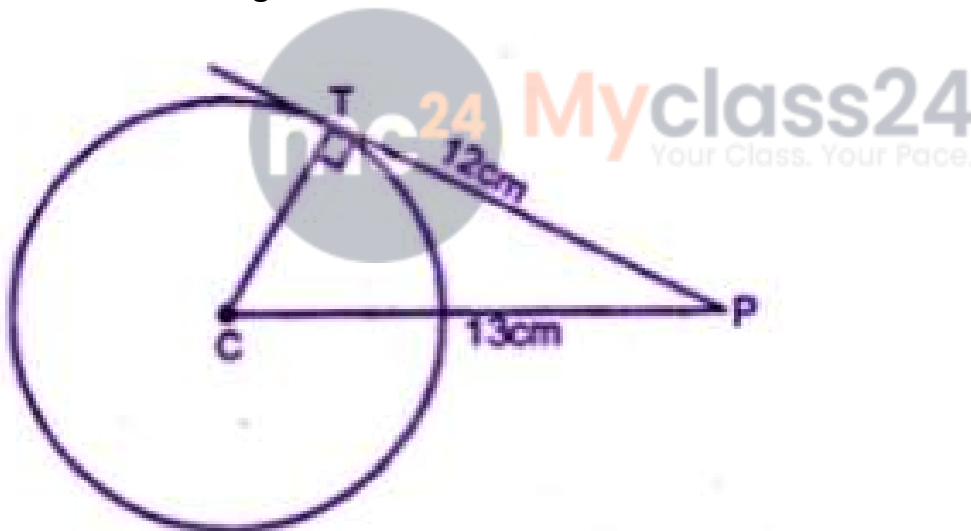

CT is the radius and TP is the tangent

CT is perpendicular TP

Now in right angled triangle CPT,

$$CP^2 = CT^2 + PT^2 \text{ [using Pythagoras axiom]}$$

$$(13)^2 = (CT)^2 + (12)^2$$

$$169 = (CT)^2 + 144$$

$$(CT)^2 = 169 - 144 = 25 = (5)^2$$

$$CT = 5 \text{ cm.}$$

Hence the radius of the circle is 5cm

3. The tangent to a circle of radius 6 cm from an external point P, is of length 8 cm. Calculate the distance of P from the nearest point of the circle.

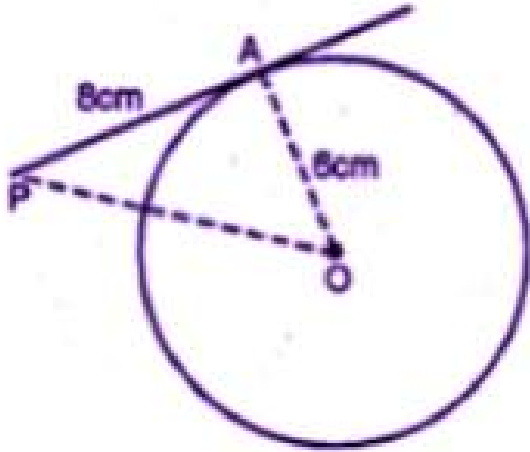

Solution:

Radius of the circle = 6 cm
and length of tangent = 8 cm

Let OP be the distance
i.e. OA = 6 cm, AP = 8 cm .

OA is the radius

$OA \perp AP$

Now In right $\triangle OAP$,

$$OP^2 = OA^2 + AP^2$$

(By Pythagoras axiom)

$$= (6)^2 + (8)^2$$

$$= 36 + 64$$

$$= 100$$

$$= (10)^2$$

$$OP = 10 \text{ cm.}$$

4. Two concentric circles are of the radii 13 cm and 5 cm. Find the length of the chord of the outer circle which touches the inner circle.

Solution:

Two concentric circles with center O

OP and OB are the radii of the circles respectively, then

OP = 5 cm, OB = 13 cm.

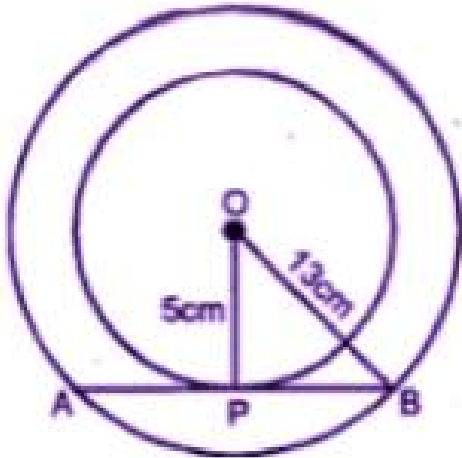

Ab is the chord of outer circle which touches the inner circle at P.
OP is the radius and APB is the tangent to the inner circle.

In the right angled triangle OPB, by Pythagoras axiom,

$$OB^2 = OP^2 + PB^2$$

$$13^2 = 5^2 + PB^2$$

$$169 = 25 + PB^2$$

$$PB^2 = 169 - 25$$

$$= 144$$

$$PB = 12 \text{ cm}$$

But P is the mid-point of AB.

$$AB = 2PB$$

$$= 24 \text{ cm}$$



5. Two circles of radii 5 cm and 2.8 cm touch each other. Find the distance between their centers if they touch :

(i) externally

(ii) internally.

Solution:

Radii of the circles are 5 cm and 2.8 cm.

i.e. OP = 5 cm and CP = 2.8 cm.

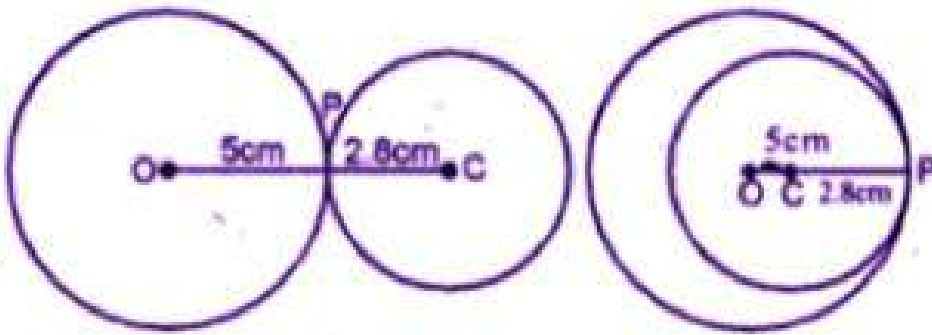

(i) When the circles touch externally,
then the distance between their centers = $OC = 5 + 2.8$
 $= 7.8$ cm.

(ii) When the circles touch internally,
then the distance between their centers = $OC = 5.0 - 2.8$
 $= 2.2$ cm

6. (a) In figure (i) given below, triangle ABC is circumscribed, find x.
(b) In figure (ii) given below, quadrilateral ABCD is circumscribed, find x.

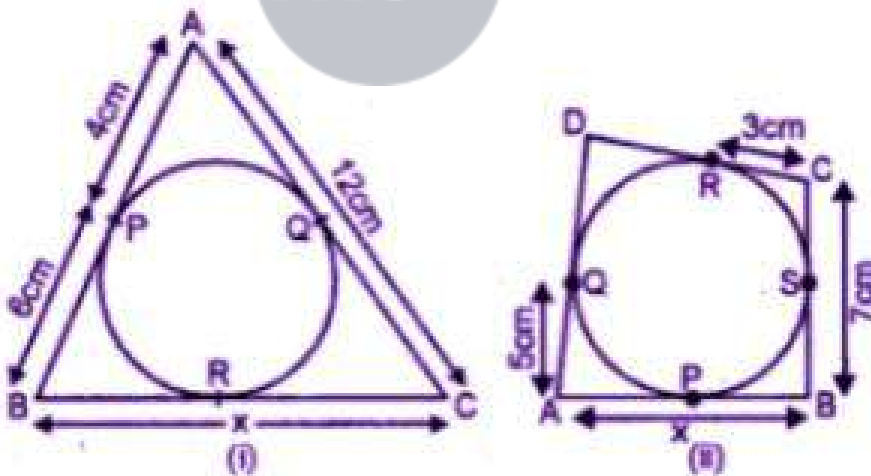

Solution:

- (a) From A, AP and AQ are the tangents to the circle
 $\therefore AQ = AP = 4$ cm

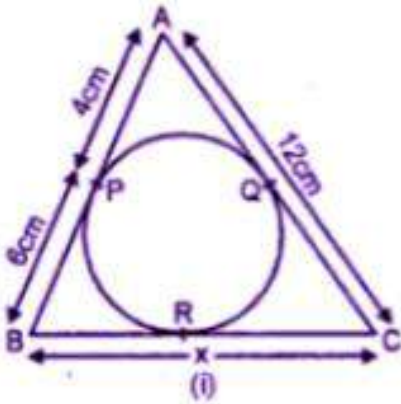

But $AC = 12$ cm

$$CQ = 12 - 4 = 8 \text{ cm.}$$

From B, BP and BR are the tangents to the circle

$$BR = BP = 6 \text{ cm.}$$

Similarly, from C,

CQ and CR the tangents

$$CR = CQ = 8 \text{ cm}$$

$$x = BC = BR + CR = 6 \text{ cm} + 8 \text{ cm} = 14 \text{ cm}$$

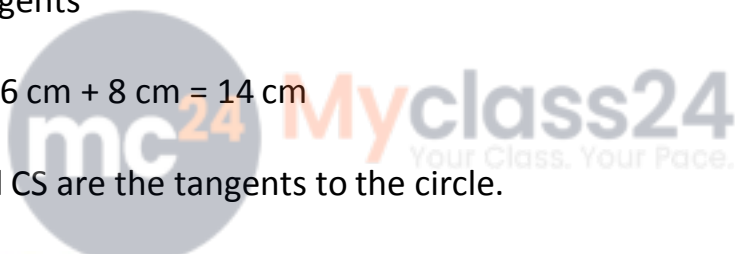

(b) From C, CR and CS are the tangents to the circle.

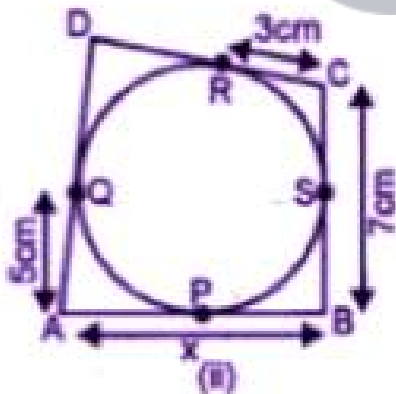

$$CS = CR = 3 \text{ cm.}$$

But $BC = 7$ cm.

$$BS = BC - CS = 7 - 3 = 4 \text{ cm.}$$

Now from B, BP and BS are the tangents to the circle.

$$BP = BS = 4 \text{ cm}$$

From A, AP and AQ are the tangents to the circle.

$$AP = AQ = 5 \text{ cm}$$

$$x = AB = AP + BP = 5 + 4 \\ = 9 \text{ cm}$$

7. (a) In figure (i) given below, quadrilateral ABCD is circumscribed; find the perimeter of quadrilateral ABCD.

(b) In figure (ii) given below, quadrilateral ABCD is circumscribed and $AD \perp DC$; find x if radius of incircle is 10 cm.

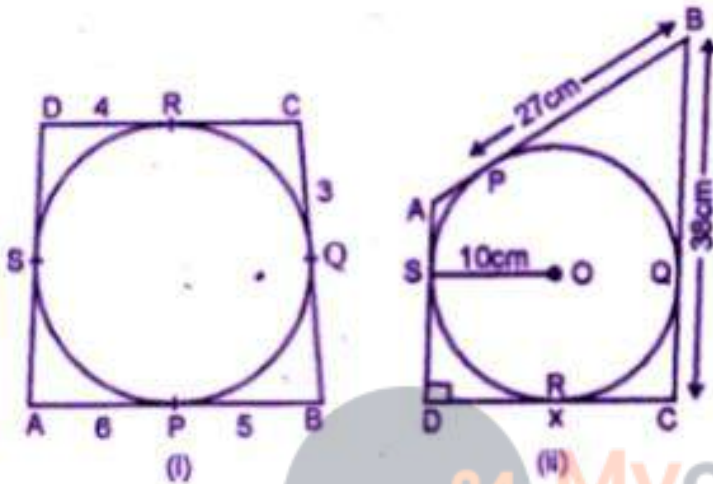

Solution:

(a) From A, AP and AS are the tangents to the circle

$$\therefore AS = AP = 6$$

From B, BP and BQ are the tangents

$$\therefore BQ = BP = 5$$

From C, CQ and CR are the tangents

$$CR = CQ$$

From D, DS and DR are the tangents

$$DS = DR = 4$$

Therefore, perimeter of the quadrilateral ABCD

$$= 6 + 5 + 5 + 3 + 3 + 4 + 4 + 6$$

$$= 36 \text{ cm}$$

(b) in the circle with center O, radius $OS = 10 \text{ cm}$

$$PB = 27 \text{ cm}, BC = 38 \text{ cm}$$

OS is the radius and AD is the tangent.

Therefore, OS perpendicular to AD.

$$SD = OS = 10 \text{ cm.}$$

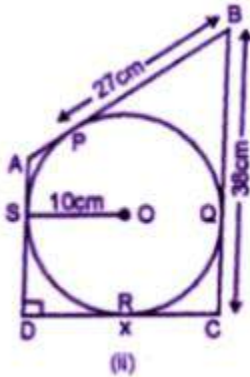

Now from D, DR and DS are the tangents
To the circle

$$DR = DS = 10 \text{ cm}$$

From B, BP and BQ are tangents to the circle.

$$BQ = BP = 27 \text{ cm.}$$

$$CQ = CB - BQ = 38 - 27 = 11 \text{ cm.}$$

Now from C, CQ and CR are the tangents to the circle

$$CR = CQ = 11 \text{ cm.}$$

$$DC = x = DR + CR \\ = 10 + 11 = 21 \text{ cm}$$



8. (a) In the figure (i) given below, O is the center of the circle and AB is a tangent at B. If $AB = 15 \text{ cm}$ and $AC = 7.5 \text{ cm}$, find the radius of the circle.

(b) In the figure (ii) given below, from an external point P, tangents PA and PB are drawn to a circle. CE is a tangent to the circle at D. If $AP = 15 \text{ cm}$, find the perimeter of the triangle PEC.

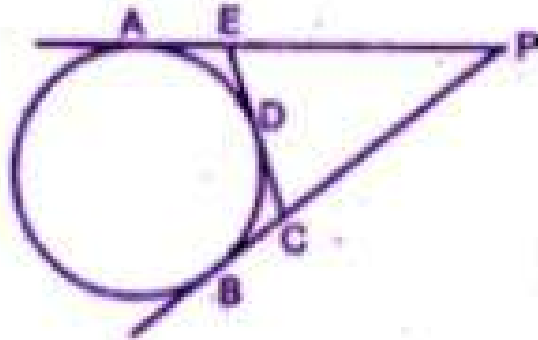
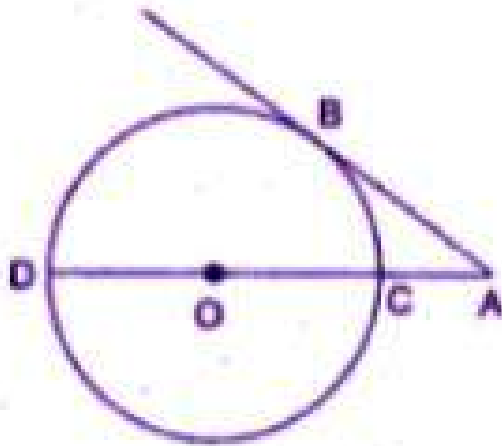

Solution:

(i) Join OB

$$\angle OBA = 90^\circ$$

(Radius through the point of contact is perpendicular to the tangent)

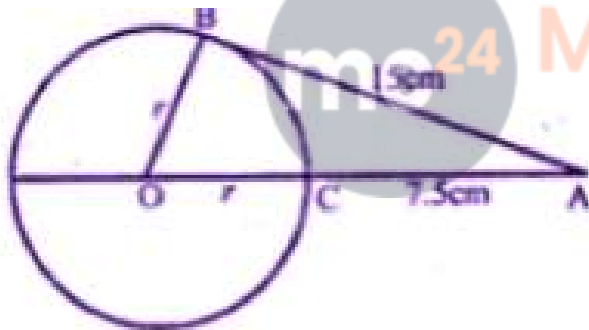

$$OB^2 = OA^2 - AB^2$$

$$r^2 = (r + 7.5)^2 - 15^2$$

$$r^2 = r^2 + 56.25 + 15r - 225$$

$$15r = 168.75$$

$$r = 11.25$$

Hence, radius of the circles = 11.25 cm

(ii) In the figure, PA and PB are the tangents
Drawn from P to the circle.

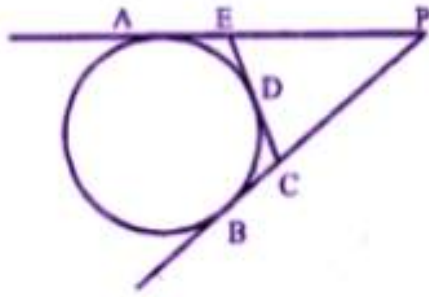

CE is tangent at D

AP = 15 cm

PA and PB are tangents to the circle

AP = BP = 15 cm

Similarly EA and ED are tangents

EA = ED

Similarly BC = CD

Now perimeter of triangle PEC,

= PE + EC + PC

= PE + ED + CD + PC

PE + EA + CB + PC

(ED = EA and CB = CD)

= AP + PB = 15 + 15

= 30 cm.



9. (a) If a , b , c are the sides of a right triangle where c is the hypotenuse, prove that the radius r of the circle which touches the sides of the triangle is given by

$$r = \frac{a + b - c}{2}$$

(b) In the given figure, PB is a tangent to a circle with center O at B. AB is a chord of length 24 cm at a distance of 5 cm from the center. If the length of the tangent is 20 cm, find the length of OP.

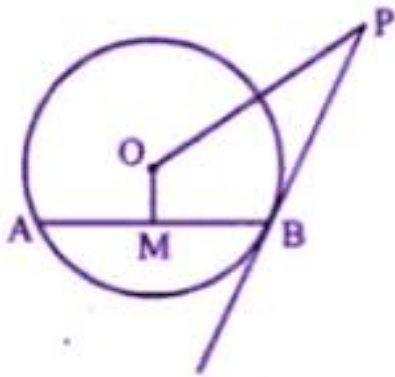

Solution:

(a) Let the circle touch the sides BC, CA and AB of the right triangle ABC at points D, E and F respectively, where $BC = a$, $CA = b$ and $AB = c$ (as showing in the given figure).

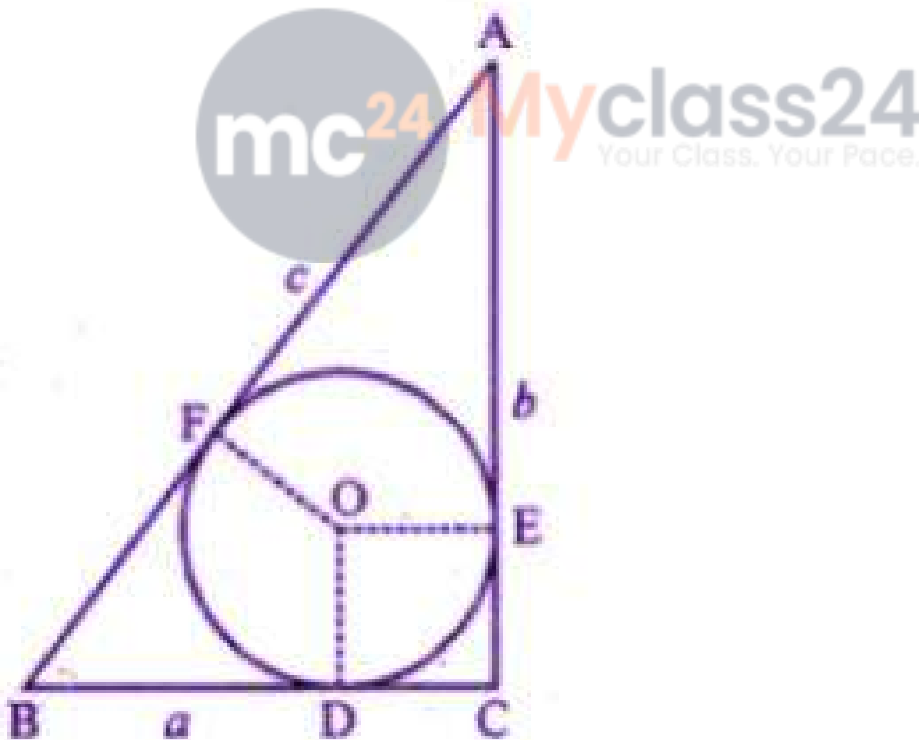

As the lengths of tangents drawn from an External point to a circle are equal
 $AE = AF$, $BD = BF$ and $CD = DE$
 $OD \perp BC$ and $OE \perp CA$

(tangents is \perp to radius)

$OD \perp BC$ and $OE \perp CA$

(tangents is \perp to radius)

ODCE is a square of side r

$DC = CE = r$

$AF = AE = AC - EC = b - r$ and

$BF = BD = BC - DC = a - r$

Now, $AB = AF + BF$

$c = (b - r) + (a - r)$

$2r = a + b - c$

$r = a + b - c/2$

$OP^2 = 400 + 169$

$OP = a - \sqrt{569} \text{cm}$

10. Three circles of radii 2 cm, 3 cm and 4 cm touch each other externally. Find the perimeter of the triangle obtained on joining the centers of these circles.

Solution:

Three circles with centers A, B and C touch each other externally at P, Q and R respectively and the radii of these circles are 2 cm, 3 cm and 4 cm.

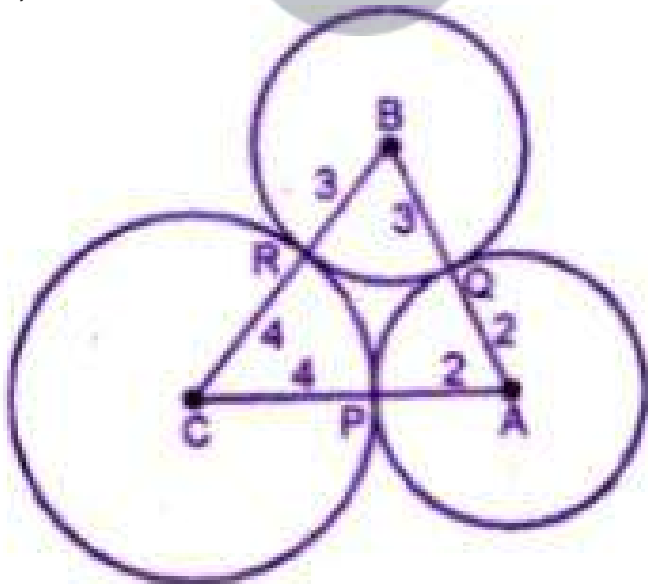

By joining the centers of triangle ABC formed in which,
 $AB = 2 + 3 = 5 \text{ cm}$

$$BC = 3 + 4 = 7 \text{ cm}$$

$$CA = 4 + 2 = 6 \text{ cm}$$

Therefore, perimeter of the triangle ABC = AB + BC + CA

$$= 5 + 7 + 6$$

$$= 18 \text{ cm}$$



CHAPTER TEST

1. (a) In the figure (i) given below, triangle ABC is equilateral. Find $\angle BDC$ and $\angle BEC$. (b) In the figure (ii) given below, AB is a diameter of a circle with center O. OD is perpendicular to AB and C is a point on the arc DB. Find $\angle BAD$ and $\angle ACD$

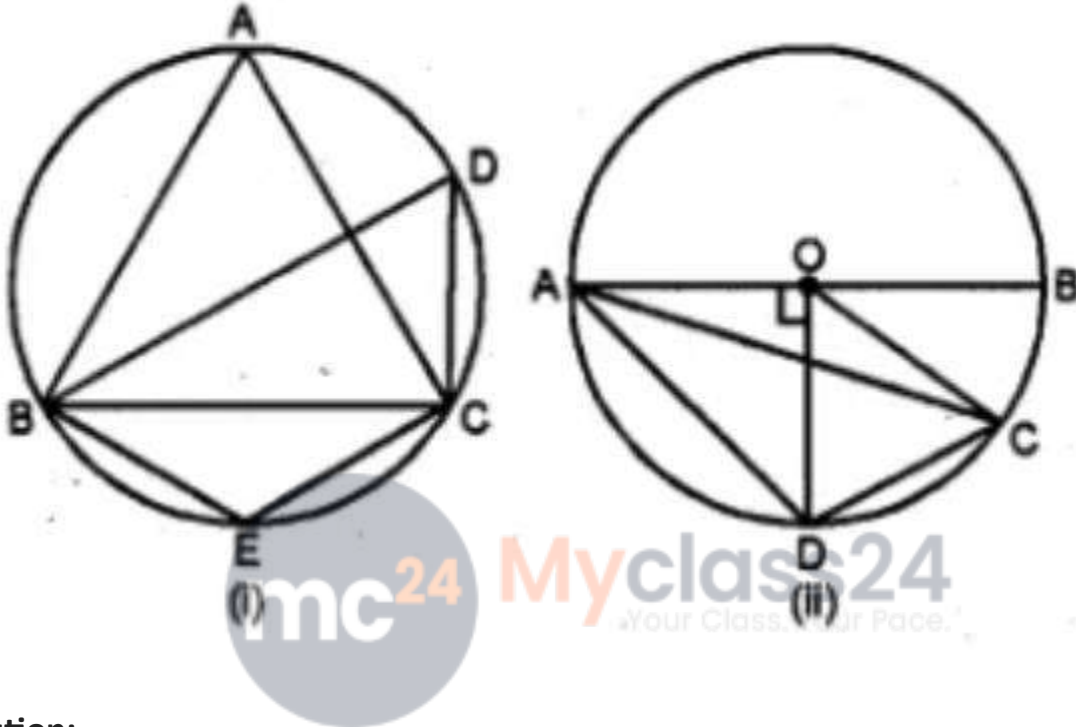

Solution:

- (a) triangle ABC is an equilateral triangle

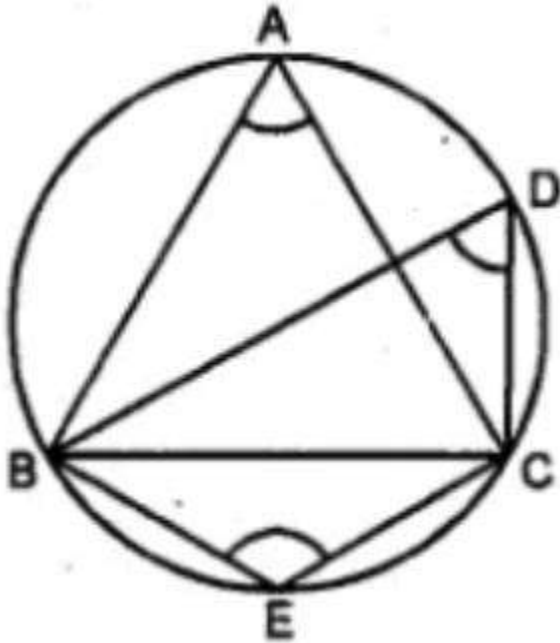

Each angle = 60°

$\angle A = 60^\circ$

But $\angle A = \angle D$

(Angles in the same segment)

$\angle D = 60^\circ$

Now ABEC is a cyclic quadrilateral,

$\angle A + \angle E = 180^\circ$

$60^\circ + \angle E = 180^\circ$

$60^\circ + \angle E = 180^\circ$ ($\angle E = 180^\circ - 60^\circ$)

$\angle E = 120^\circ$

Hence $\angle BDC = 60^\circ$ and $\angle BEC = 120^\circ$

(c) AB is diameter of circle with centre O.

OD \perp AB and C is a point on arc DB.

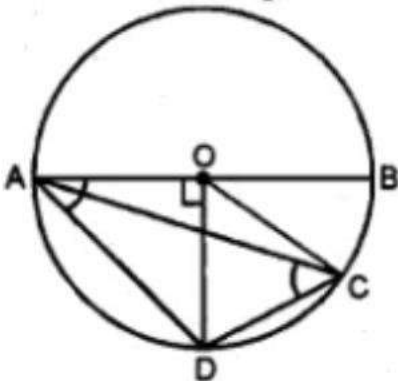

In $\triangle AOD$, $\angle AOD = 90^\circ$

$OA = OD$ (radii of the semi – circle)

$\angle OAD = \angle ODA$

But $\angle OAD + \angle ODA = 90^\circ$

$\angle OAD + \angle ODA = 90^\circ$

$2\angle OAD = 90^\circ$

$\angle OAD = 90^\circ/2 = 45^\circ$

Or $\angle BAD = 45^\circ$

(ii) Arc AD subtends $\angle AOD$ at the centre and

$\angle ACD$ at the remaining part of the circle

$\angle AOD = 2 \angle ACD$

$90^\circ = 2 \angle ACD$ ($OD \perp AB$)

$\angle ACD = 90^\circ/2 = 45^\circ$

2. (a) In the figure given below, AB is a diameter of the circle. If $AE = BE$ and $\angle ADC = 118^\circ$, find (i) $\angle BDC$ (ii) $\angle CAE$

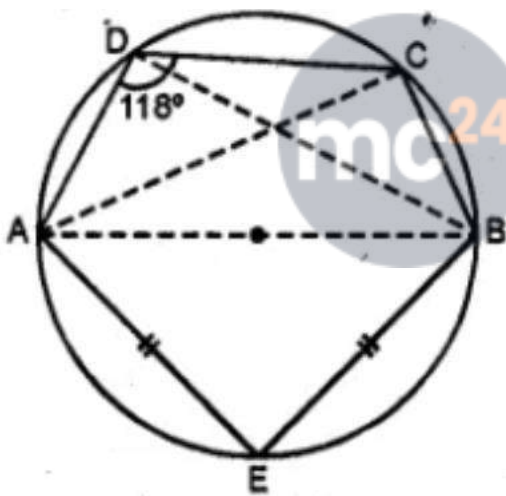

(B) In the figure given below, AB is the diameter of the semi-circle ABCDE with centre O. If $AE = ED$ and $\angle BCD = 140^\circ$, find $\angle AED$ and $\angle EBD$. Also Prove that OE is parallel to BD.

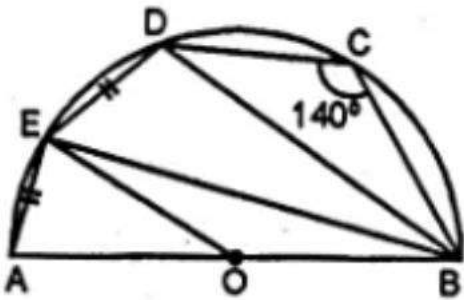

Solution:

(a) Join DB, CA and CB. $\angle ADC = 118^\circ$ (given) and $\angle ADB = 90^\circ$

(Angles in a semi-circle)

$$\angle BDC = \angle ADC - \angle ADB$$

$$= 118^\circ - 90^\circ = 28^\circ$$

$\angle ABCD$ is a cyclic quadrilateral)

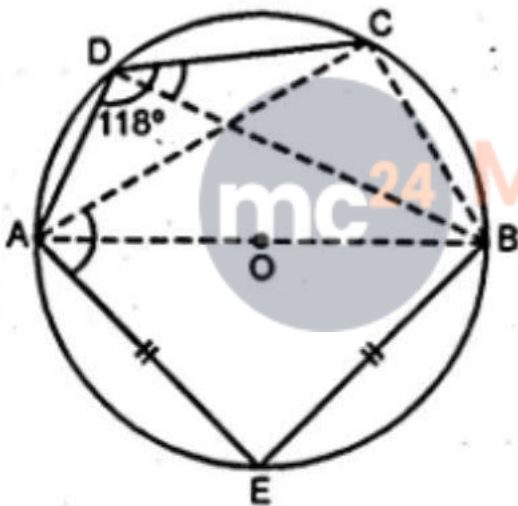

$$\angle ADC + \angle ABC = 180^\circ$$

$$118^\circ + \angle ABC = 180^\circ$$

$$\angle ABC = 180^\circ - 118^\circ = 62^\circ$$

But in $\triangle AEB$

$$\angle AEB = 90^\circ$$

(Angles in a semi-circle)

$$\angle EAB = \angle ABE \text{ (AE = BE)}$$

$$\angle EAB + \angle ABE = 90^\circ$$

$$\angle EAB = 90^\circ \times \frac{1}{2} = 45^\circ$$

$$\angle CBE = \angle ABC + \angle ABE$$

$$= 62^\circ + 45^\circ = 107^\circ$$

But AEBD is a cyclic quadrilateral

$$\angle CAE + \angle CBE = 180^\circ$$

$$\angle CAE + 107^\circ = 180^\circ$$

$$\angle CAE = 180^\circ - 107^\circ = 73^\circ$$

(b) AB is the diameter of semi-circle ABCDE

With center O. $AE = ED$ and $\angle BCD = 140^\circ$

In cyclic quadrilateral EBCD.

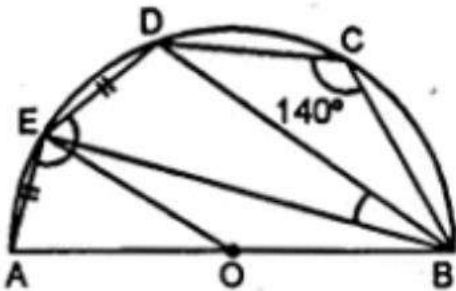

$$(i) \angle BCD + \angle BED = 180^\circ$$

$$140^\circ + \angle BED = 180^\circ$$

$$\angle BED = 180^\circ - 140^\circ = 40^\circ$$

$$\text{But } \angle AED = 90^\circ$$

(Angles in a semi circle)

$$\angle AED = \angle AEB + \angle BED$$

$$= 90^\circ + 40^\circ = 130^\circ$$

(ii) Now in cyclic quadrilateral AEDB

$$\angle AED + \angle DBA = 180^\circ$$

$$130^\circ + \angle DBA = 180^\circ$$

$$\angle BDA = 180^\circ - 130^\circ = 50^\circ$$

Chord $AE = ED$ (given)

$$\angle DBE = \angle EBA$$

$$\text{But } \angle DBE + \angle EBA = 50^\circ$$

$$\angle DBE + \angle DBE = 50^\circ$$

$$2\angle DBE = 50^\circ$$

$$\angle DBE = 25^\circ \text{ or } \angle EBD = 25^\circ$$

In $\triangle OEB$, $OE = OB$

(radii of the same circle)

$$\angle OEB = \angle EBO = \angle DBE$$

But these are ultimate angles
 $OE \parallel BD$

3. a) In the figure (i) given below, O is the centre of the circle. Prove that $\angle AOC = 2(\angle ACB + \angle BAC)$. (b) In the figure (ii) given below, O is the centre of the circle. Prove that $x + y = z$

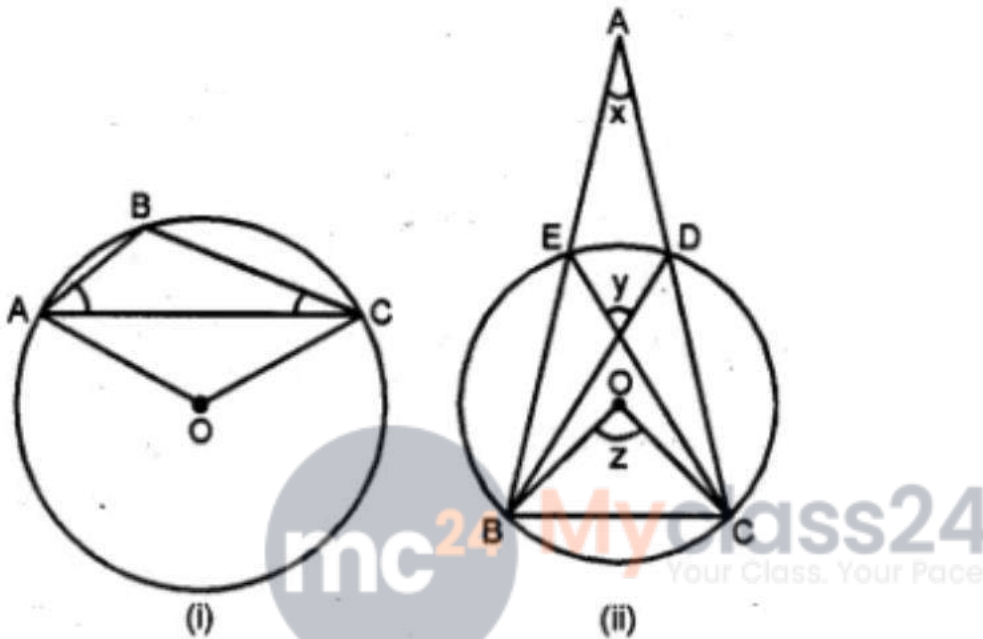

Solution :

(a) Given: O is the center of the circle. **To Prove :** $\angle AOC = 2(\angle ACB + \angle BAC)$. **Proof:** In

$\triangle ABC$, $\angle ACB + \angle BAC + \angle ABC = 180^\circ$ (Angles of a triangle)

$\angle ABC = 180^\circ - (\angle ACB + \angle BAC) \dots (i)$

In the circle, arc AC subtends $\angle AOC$ at

The center and $\angle ABC$ at the remaining part of the circle.

Reflex $\angle AOC = 2 \angle ABC \dots (ii)$

Reflex $\angle AOC = 2 \{ (180^\circ - (\angle ACB + \angle BAC)) \}$

But $\angle AOC = 360^\circ - 2(\angle ACB + \angle BAC)$

But $\angle AOC = 360^\circ - \text{reflex } \angle AOC$

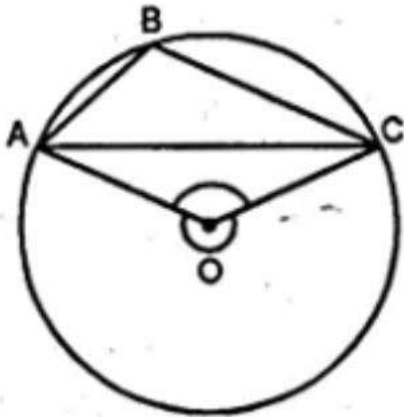

$$\begin{aligned}
 &= 360^\circ - (360^\circ - 2(\angle ACB + \angle BAC)) \\
 &= 360^\circ - 360^\circ + 2(\angle ACB + \angle BAC) \\
 &= 2(\angle ACB + \angle BAC) \\
 \text{Hence } \angle AOC &= 2(\angle ACB + \angle BAC)
 \end{aligned}$$

(b) Given : in the figure, O is the center of the circle
 To Prove : $x + y = z$.

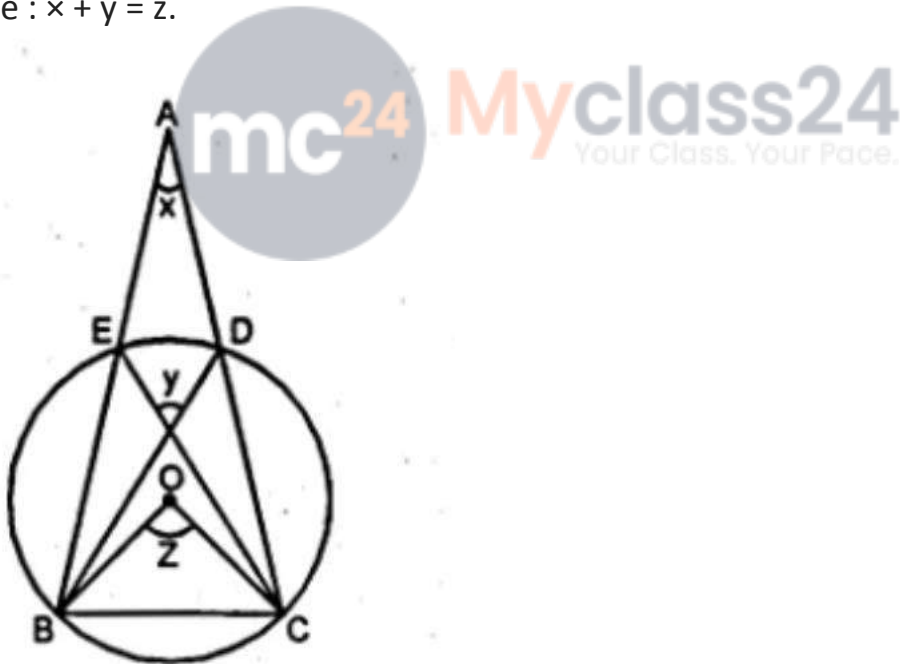

Proof : Arc BC subtends $\angle AOB$ at the center and $\angle BEC$ at the remaining part of the circle.

$$\angle BOC = 2 \angle BEC$$

$$\text{But } \angle BEC = \angle BDC$$

(Angles in the same segment)

$$\angle BOC = \angle BEC + \angle BDC \dots\dots (ii)$$

Similarly in $\triangle ABD$

$$\text{Ext. } \angle BDC = x + \angle ABD$$

$$= x + \angle EBD \quad \dots\dots\dots(\text{iii})$$

Substituting the value of (ii) and (iii) in (i)

$$\angle BOC = y - \angle EBD + x + \angle EBD = x + y$$

$$Z = x + y$$

