

EXERCISE 14.1

1. Construct a quadrilateral PQRS where $PQ = 4.5$ cm, $QR = 6$ cm, $RS = 5.5$ cm, $PS = 5$ cm and $PR = 6.5$ cm.

Solution:

Steps of Construction:

(i) Construct a line segment $PR = 6.5$ cm.

(ii) Taking P as centre and 4.5 cm radius and R as centre and 6 cm radius construct arcs which intersect each other at Q.

(iii) Now join PQ and QR.

(iv) Taking P as centre and 5 cm radius and R as centre and 5.5 cm radius, construct arcs which intersect each other at S.

(v) Join PS and SR.

Hence, PQRS is the required quadrilateral.

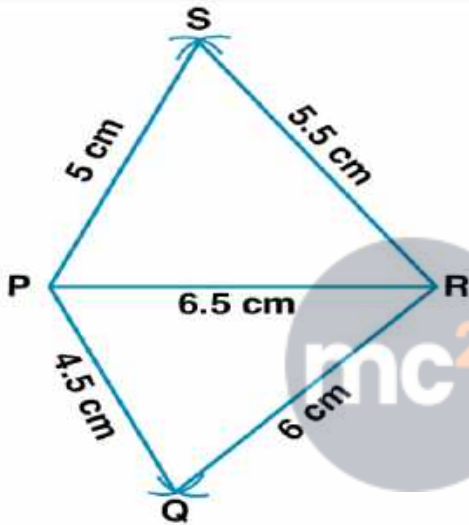

2. Construct a quadrilateral ABCD in which $AB = 3.5$ cm, $BC = 5$ cm, $CD = 5.6$ cm, $DA = 4$ cm, $BD = 5.4$ cm.

Solution:

Steps of Construction:

(i) Construct a line segment $AB = 3.5$ cm.

(ii) Taking A as centre and 4 cm radius construct an arc and with B as centre and 5.4 cm construct an arc which meets the previous arc at the point D.

Now join AD and BD.

(iii) Taking B as centre and 5 cm radius, construct an arc

Taking D as centre and 5.6 cm radius, construct an arc which meets the previous arc at the point C.

(iv) Join BC and CD.

Hence, ABCD is the required quadrilateral.

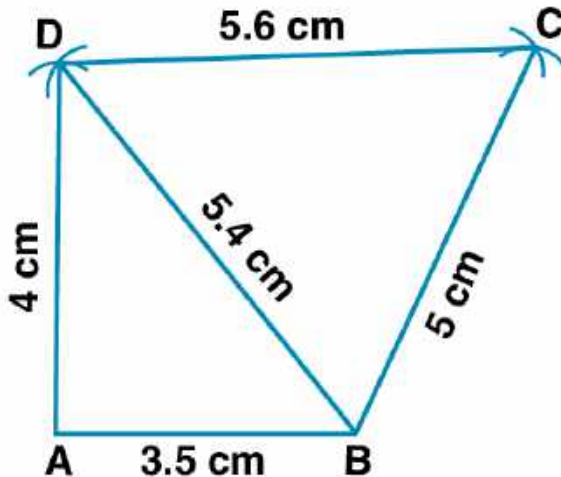

3. Construct a quadrilateral PQRS in which $PQ = 3$ cm, $QR = 2.5$ cm, $PS = 3.5$ cm, $PR = 4$ cm and $QS = 5$ cm.

Solution:

Steps of Construction:

(i) Construct $PQ = 3$ cm.

(ii) Taking P as centre and 4 cm radius, construct an arc

Taking Q as centre and 2.5 cm radius, construct an arc which meets the previous arc at R

Now join PQ and QR

(iii) Taking P as centre and 3.5 cm radius, construct an arc

Taking Q as centre and 5 cm radius, construct an arc which meets the previous arc at S.

(iv) Join PS, QS and SR.

Therefore, PQRS is the required quadrilateral.

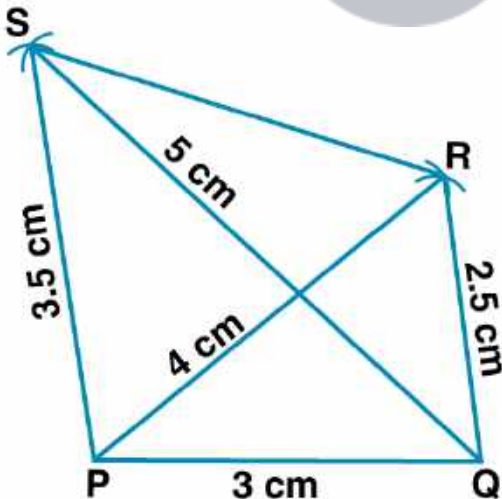

4. Construct a quadrilateral ABCD such that $BC = 5$ cm, $AD = 5.5$ cm, $CD = 4.5$ cm, $AC = 7$ cm and $BC = 5.5$ cm.

Solution:

Steps of Construction:

(i) Construct a line segment $CD = 4.5$ cm.

**ML Aggarwal Solutions for Class 8 Maths Chapter 14 –
Constructions of Quadrilaterals**

- (ii) Taking C as centre and 5.5 cm radius and taking D as centre and 7 cm radius construct arcs which intersect each other at B.
- (iii) Join BC and BD.
- (iv) Taking C as centre and 5.5 cm radius and taking D as centre and 5.5 cm radius, construct arcs which intersect each other at A.
- (v) Now join AC and AD.
- (vi) Join AB.
- Therefore, ABCD is the required quadrilateral.

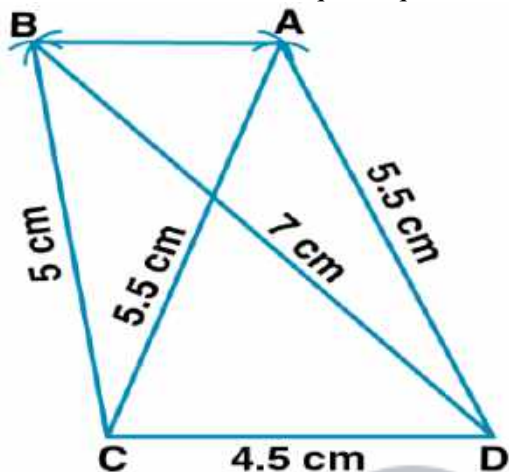

5. Construct a quadrilateral ABCD given that $BC = 6$ cm, $CD = 4$ cm, $\angle B = 45^\circ$, $\angle C = 90^\circ$ and $\angle D = 120^\circ$.

Solution:

Steps of Construction:

- (i) Construct $BC = 6$ cm.
- (ii) At the point B, draw $\angle CBP = 45^\circ$.
- (iii) At the point C, draw $\angle BCQ = 90^\circ$.
- (iv) Cut off $CD = 4$ cm from CQ .
- (v) At the point D, draw $\angle CDR = 120^\circ$.
- (vi) Let BP and DR meet at the point A.

Therefore, ABCD is the required quadrilateral.

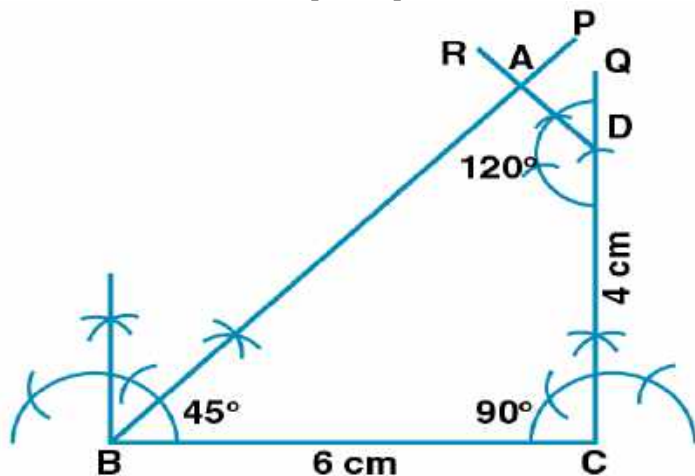

6. Construct a quadrilateral PQRS where $PQ = 4$ cm, $QR = 6$ cm, $\angle P = 60^\circ$, $\angle Q = 90^\circ$ and $\angle R = 120^\circ$.

ML Aggarwal Solutions for Class 8 Maths Chapter 14 –
Constructions of Quadrilaterals

Solution:

Steps of Construction:

(i) Construct a line segment $QR = 6$ cm.

(ii) At the point Q, construct a ray QX making an angle of 90° and cut off $QP = 4$ cm.

(iii) At the point P, construct a ray making an angle of 60° and at R, a ray making an angle 120° which meets each other at the point S.

Therefore, PQRS is the required quadrilateral.

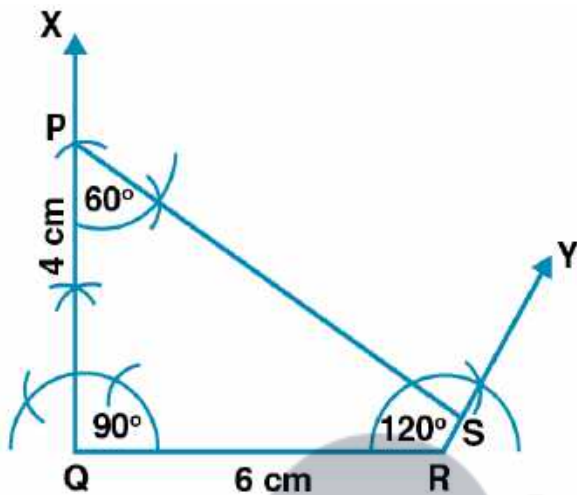

7. Construct a quadrilateral ABCD such that $AB = 5$ cm, $BC = 4.2$ cm, $AD = 3.5$ cm, $\angle A = 90^\circ$ and $\angle B = 60^\circ$.

Solution:

Steps of Construction:

(i) Construct $AB = 5$ cm.

(ii) At the point A, construct $\angle A = 90^\circ$.

(iii) At the point B, construct $\angle B = 60^\circ$.

(iv) Taking B as centre and radius 4.2 cm cut off $\angle B$ at C.

(v) Taking A as centre and radius 3.5 cm cut off $\angle A$ at D.

(vi) Now join CD.

Therefore, ABCD is the required quadrilateral.

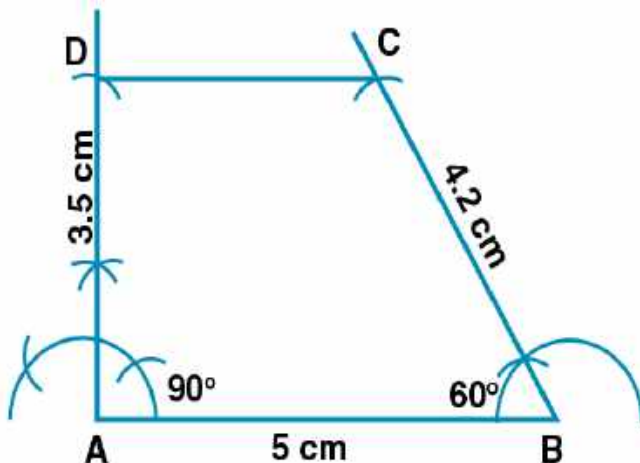

ML Aggarwal Solutions for Class 8 Maths Chapter 14 –
Constructions of Quadrilaterals

8. Construct a quadrilateral PQRS where $PQ = 4$ cm, $QR = 5$ cm, $RS = 4.5$ cm, $\angle Q = 60^\circ$ and $\angle R = 90^\circ$.

Solution:

Steps of Construction:

(i) Construct a line segment $QR = 5$ cm.

(ii) At the point Q, construct a ray QX making an angle of 60° and cut off $QP = 4$ cm.

(iii) At the point R, construct a ray RY making an angle of 90° and cut off $RS = 4.5$ cm.

(iv) Now join PS.

Therefore, PQRS is the required quadrilateral.

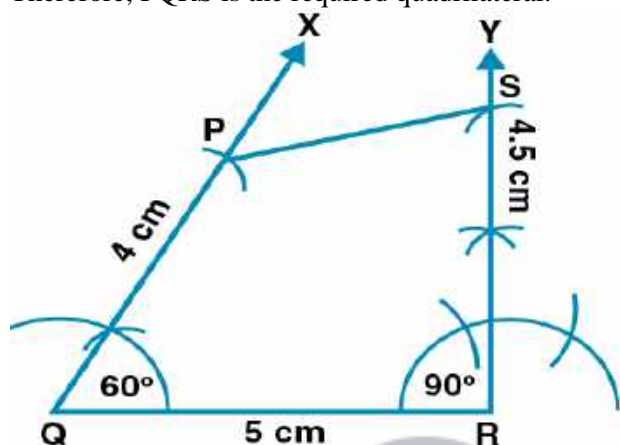

9. Construct a quadrilateral BEST where $BE = 3.8$ cm, $ES = 3.4$ cm, $ST = 4.5$ cm, $TB = 5$ cm and $\angle E = 80^\circ$.

Solution:

Steps of Construction:

(i) Construct a line segment $BE = 3.8$ cm.

(ii) At the point E, construct a ray EX making an angle of 80° and cut off $ES = 3.4$ cm.

(iii) Taking B as centre and 5 cm radius and S as centre and 4.5 cm radius, construct arcs which intersect each other at T.

(iv) Now join TB and TS.

Therefore, BEST is the required quadrilateral.

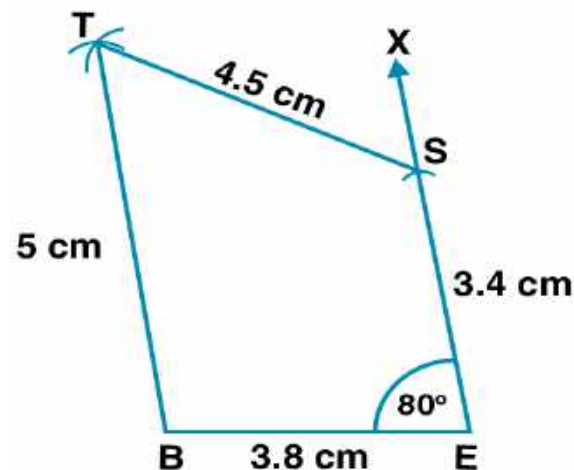

10. Construct a quadrilateral ABCD where $AB = 4.5$ cm, $BC = 4$ cm, $CD = 3.9$ cm, $AD = 3.2$ cm and $\angle B = 60^\circ$.

**ML Aggarwal Solutions for Class 8 Maths Chapter 14 –
Constructions of Quadrilaterals**

Solution:

Steps of Construction:

- (i) Construct $AB = 4.5$ cm.
- (ii) At point B, construct $\angle ABP = 60^\circ$.
- (iii) Cut off $BC = 4$ cm from BP.
- (iv) Taking C as centre and radius 3.9 cm construct an arc.
- (v) Taking A as centre and radius 3.2 cm construct an arc which meets the previous arc at D.
- (vi) Now join AD and CD.

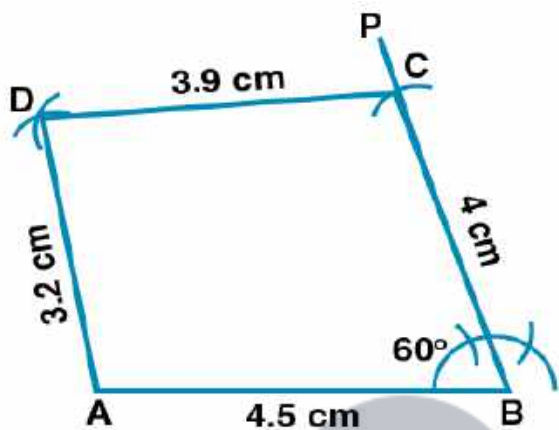

EXERCISE 14.2

1. Construct a parallelogram ABCD such that $AB = 5$ cm, $BC = 3.2$ cm and $\angle B = 120^\circ$.

Solution:

Steps of Construction:

- (i) Construct $AB = 5$ cm.
- (ii) At point B, draw angle 120° .
- (iii) Taking B as centre and radius 3.2 cm cut off $\angle B$ at C.
- (iv) Taking C as centre and radius AB construct an arc.
- (v) Taking A as centre and radius 3.2 cm, construct an arc which meets the previous arc at D.
- (vi) Now join AD and CD.

Therefore, ABCD is the required parallelogram.

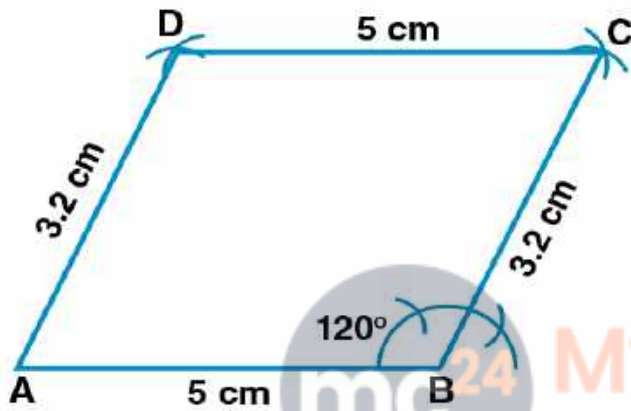

2. Construct a parallelogram ABCD such that $AB = 4.8$ cm, $BC = 4$ cm and diagonal $BD = 5.4$ cm.

Solution:

Steps of Construction:

- (i) Draw a triangle ABCD.
- (ii) Taking B as centre and radius 4 cm, construct an arc.
- (iii) Taking D as centre and radius 4.8 cm, construct an arc which meets the previous arc at C.
- (iv) Now join CD, BC and AC.

Therefore, ABCD is the required parallelogram.

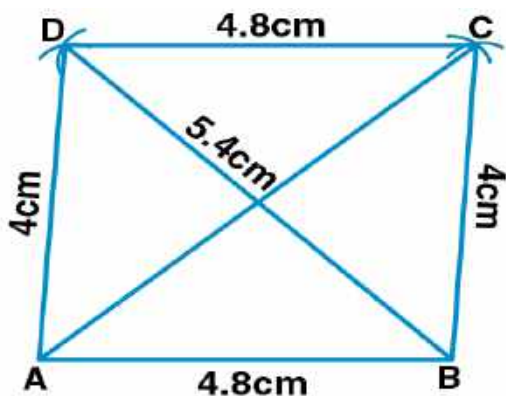

3. Construct a parallelogram ABCD such that $BC = 4.5$ cm, $BD = 4$ cm and $AC = 5.6$ cm.

Solution:

Steps of Construction:

(i) Draw a triangle BOC with $BC = 4.5$ cm

Here

$$BO = \frac{1}{2} \times 4 = 2 \text{ cm}$$

$$OC = \frac{1}{2} AC$$

$$= \frac{1}{2} \times 5.6$$

$$= 2.8 \text{ cm}$$

We know that the diagonals of parallelogram bisect each other.

(ii) Produce OC to point A such that $OC = OA$.

(iii) Produce BO to point D such that $OD = OB$.

(iv) Now join AD.

Therefore, ABCD is the required parallelogram.

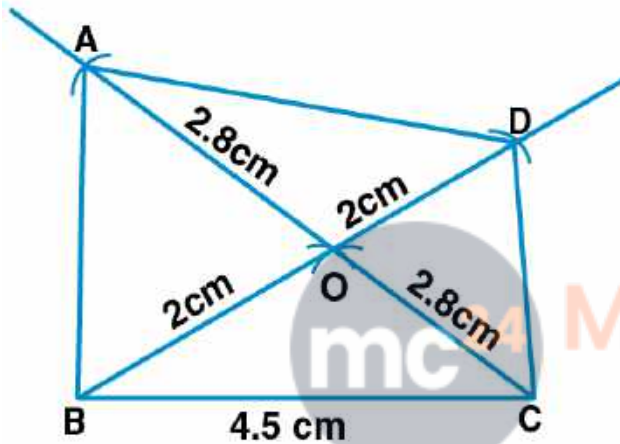

4. Construct a parallelogram ABCD such that $AC = 6$ cm, $BD = 4.6$ cm and angle between them is 45° .

Solution:

Steps of Construction:

(i) Construct $AO = \frac{1}{2} AC = 3$ cm and produce AO to C such that $OC = OA$.

(ii) At the point O, draw $\angle COP = 45^\circ$.

(iii) From O

Cut $OD = \frac{1}{2} BD$

$$= \frac{1}{2} \times 4.6$$

$$= 2.3 \text{ cm}$$

(iv) Produce OD to OB such that $OB = OD$.

(v) Now join AB, BC, CD and DA.

Therefore, ABCD is the required parallelogram.

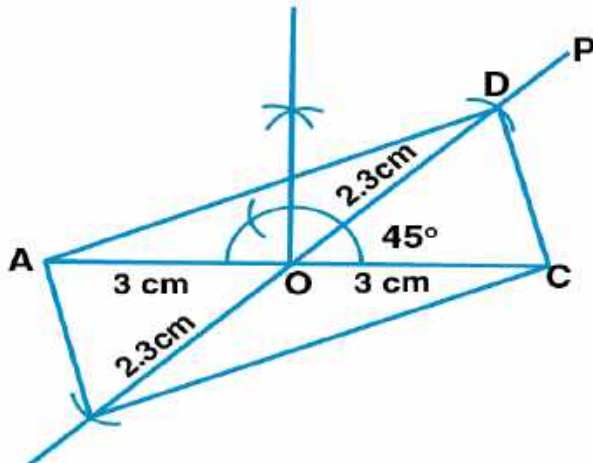

5. Construct a rectangle whose adjacent sides are 5.6 cm and 4 cm.
Solution:

Steps of Construction:

- (i) Construct $AB = 5.6$ cm.
- (ii) At the point B, draw $\angle ABP = 90^\circ$.
- (iii) Cut off $BC = 4$ cm from BP.
- (iv) Taking C as centre and 5.6 cm radius, construct an arc.
- (v) Taking A as centre and 4 cm radius, construct an arc which meets the previous arc at point D.
- (vi) Now join AD and CD.

Therefore, ABCD is the required rectangle.

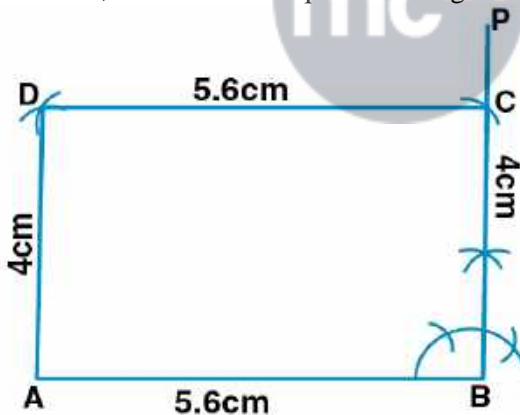

6. Construct a rectangle such that one side is 5 cm and one diagonal is 6.8 cm.
Solution:

Steps of Construction:

- (i) Construct $AB = 5$ cm.
- (ii) At the point A, draw $\angle BAP = 90^\circ$.
- (iii) Taking B as centre and 6.8 cm radius, construct an arc which meets AP at D.
- (iv) Taking A as centre and 6.8 cm radius, construct an arc.
- (v) Taking D as centre and 5 cm radius, construct an arc which meets the previous arc at C.
- (vi) Now join BC and CD.

Therefore, ABCD is the required rectangle.

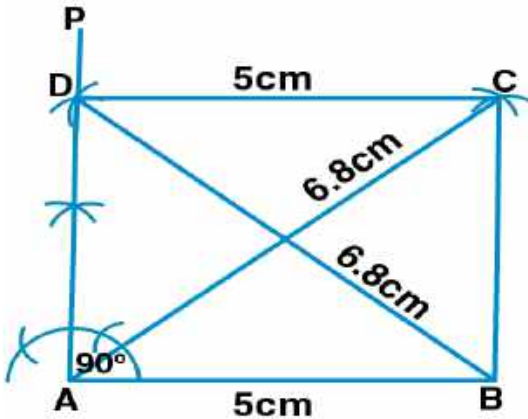

7. Construct a rectangle ABCD such that $AB = 4$ cm and $\angle BAC = 60^\circ$.

Solution:

Steps of Construction:

- (i) Construct $AB = 4$ cm.
- (ii) At the point B, construct $\angle ABP = 90^\circ$.
- (iii) At the point A, draw $\angle BAQ = 30^\circ$. Let AQ meet BP at the point D.
- (iv) Taking D as centre and 4 cm radius construct an arc.
- (v) Taking A as centre and BD as radius, construct an arc which meets the previous arc at the point C.
- (vi) Now join AC and CD.

Therefore, ABCD is the required rectangle.

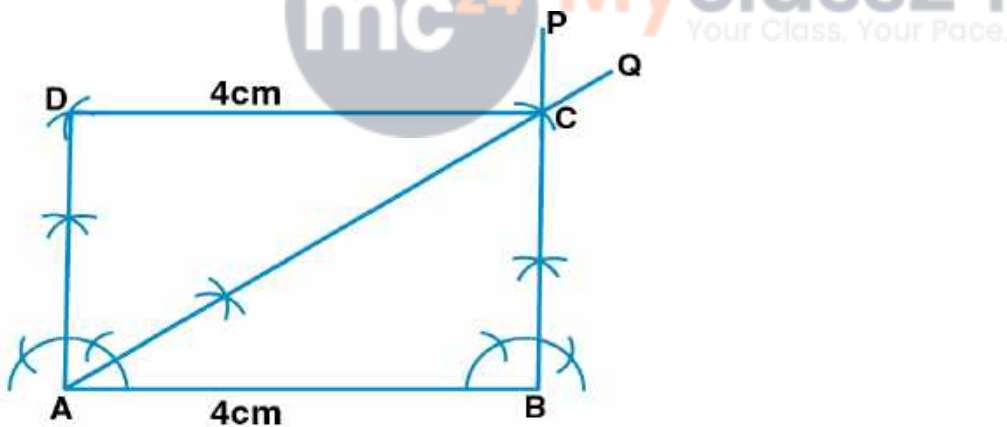

8. Construct a rectangle such that one diagonal is 6.6 cm and angle between two diagonals is 120° .

Solution:

Steps of Construction:

- (i) Construct $AO = \frac{1}{2} AC = (\frac{1}{2} \times 6.6)$ cm and produce AO to C such that $OC = OA = 3.3$ cm.
- (ii) At the point O, draw $\angle COB = 120^\circ$.
- (iii) Cut off $OB = \frac{1}{2} AC = 3.3$ cm from OB.
- (iv) Produce BO to D such that $OB = OD = 3.3$ cm.
- (v) Now join AB, BC, CD and DA.

Therefore, ABCD is the required rectangle.

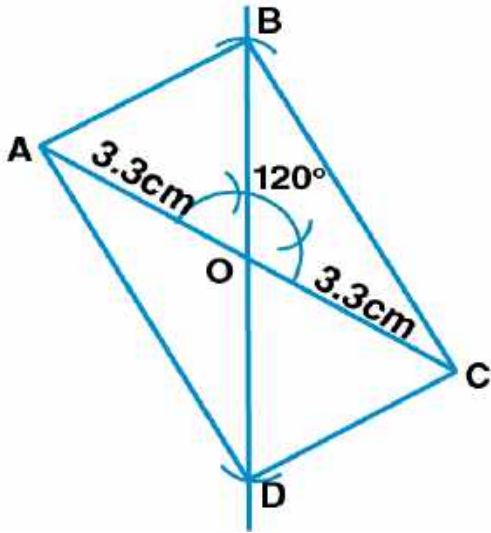

9. Construct a rhombus whose one side is 5 cm and one angle is 45° .

Solution:

Steps of Construction:

(i) Construct $AB = 5$ cm.

(ii) At the point A, draw $\angle BAP = 45^\circ$.

(iii) Cut off $AD = 5$ cm from AP.

(iv) Taking B as centre and 5 cm radius, construct an arc.

(v) Taking D as centre and 5 cm radius, construct an arc which meets the previous arc at the point C.

(vi) Now join BC and CD.

Therefore, ABCD is the required rhombus.

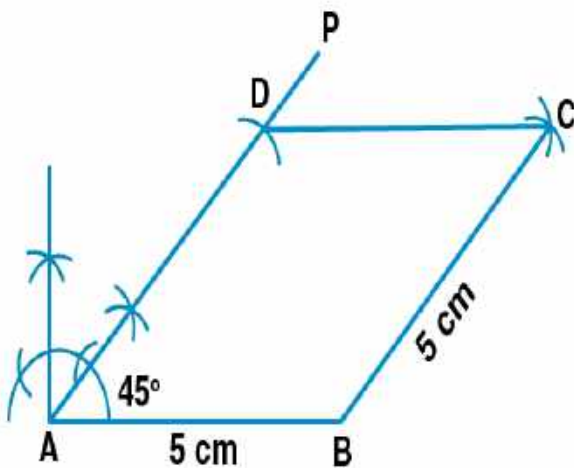

10. Construct a rhombus whose one side is 4.5 cm and one diagonal is 5 cm.

Solution:

Steps of Construction:

(i) Construct $AB = 4.5$ cm.

(ii) Taking A as centre and 4.5 cm radius, construct an arc.

**ML Aggarwal Solutions for Class 8 Maths Chapter 14 –
Constructions of Quadrilaterals**

- (iii) Taking B as centre and 5 cm radius, construct an arc which meets the previous arc at D.
 - (iv) Taking B as centre and 4.5 cm radius, construct an arc.
 - (v) Taking D as centre and 4.5 cm radius, construct an arc which meets the previous arc at point C.
 - (vi) Now join AD, BC and CD.
- Therefore, ABCD is the required rhombus.

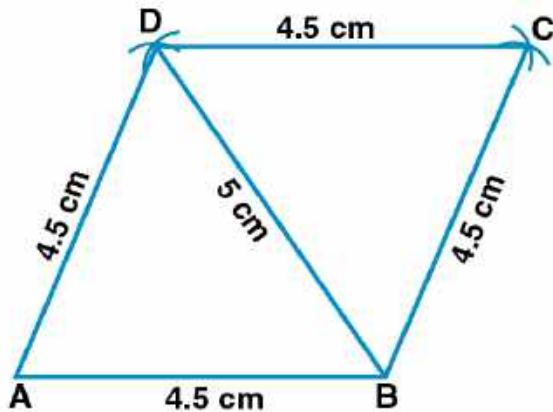

11. Construct a rhombus whose diagonals are 6.8 cm and 5.2 cm.

Solution:

Steps of Construction:

- (i) Construct AC = 6.8 cm.
- (ii) Construct one bisector PQ of AC to meet it at the point O.
- (iii) From POQ, cut off OB and OD such that $OB = OD = \frac{1}{2} BD = \frac{1}{2} \times 5.2 = 2.6$ cm
- (iv) Now join AB, BC, CD and DA.

Therefore, ABCD is the required rhombus.

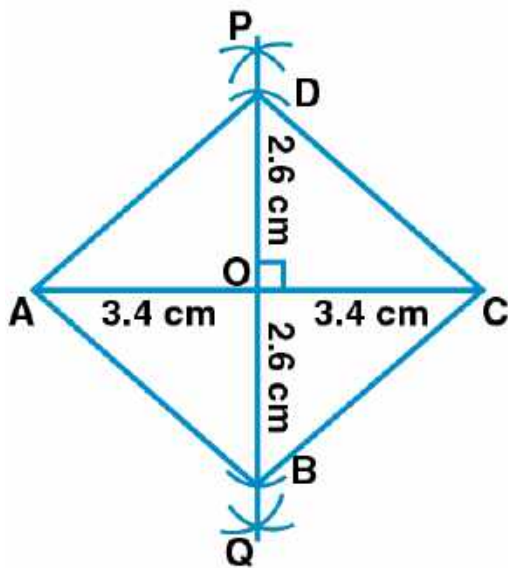

12. Construct a square whose one side is 4.3 cm.

Solution:

ML Aggarwal Solutions for Class 8 Maths Chapter 14 –
Constructions of Quadrilaterals

Steps of Construction:

- (i) Construct $BC = 4.3$ cm.
- (ii) At the point B, draw $\angle CBP = 90^\circ$.
- (iii) Cut off $BA = 4.3$ cm from BP.
- (iv) Taking C as centre and 4.3 cm radius, construct an arc.
- (v) Taking A as centre and 4.3 cm radius, construct an arc which meets the previous arc at D.
- (vi) Now join AD and CD.

Therefore, ABCD is the required square.

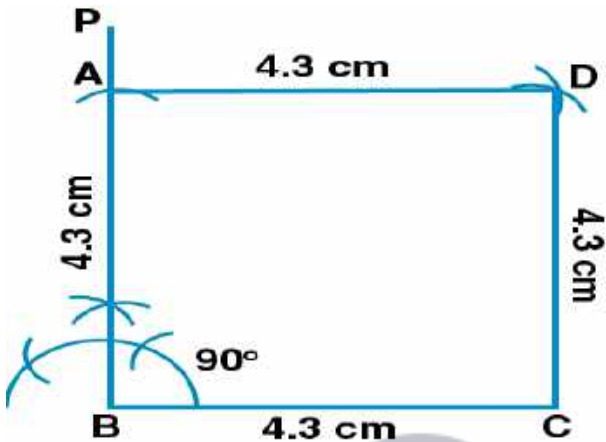

13. Construct a square whose one diagonal is 6.2 cm.

Solution:

Steps of Construction:

- (i) Construct $AC = 6.2$ cm.
- (ii) Construct a perpendicular bisector PQ of AC to meet it at point O.
- (iii) From POQ, cut off $OB = OD = \frac{1}{2} AC = 3.1$ cm.
- (iv) Now join AB, BC, CD and DA.

Therefore, ABCD is the required square.

