

Activities for Class XII

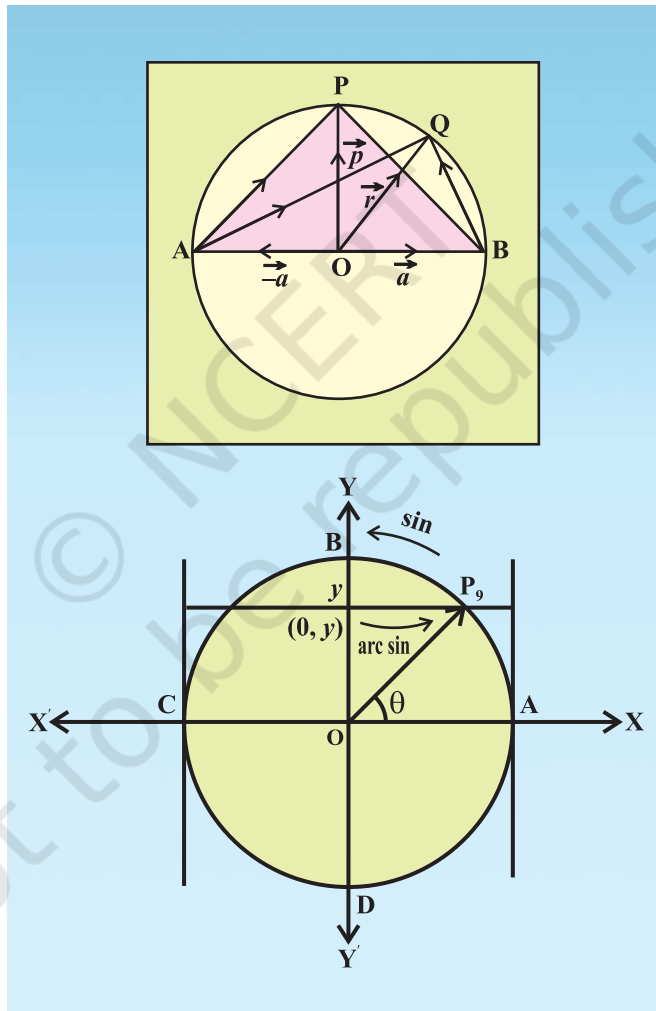

*The basic principles of learning mathematics are :
(a) learning should be related to each child individually
(b) the need for mathematics should develop from an intimate acquaintance with the environment (c) the child should be active and interested, (d) concrete material and wide variety of illustrations are needed to aid the learning process (e) understanding should be encouraged at each stage of acquiring a particular skill (f) content should be broadly based with adequate appreciation of the links between the various branches of mathematics, (g) correct mathematical usage should be encouraged at all stages.*

– Ronwill

Activity 1

OBJECTIVE

To verify that the relation R in the set L of all lines in a plane, defined by $R = \{(l, m) : l \perp m\}$ is symmetric but neither reflexive nor transitive.

MATERIAL REQUIRED

A piece of plywood, some pieces of wires (8), nails, white paper, glue etc.

METHOD OF CONSTRUCTION

Take a piece of plywood and paste a white paper on it. Fix the wires randomly on the plywood with the help of nails such that some of them are parallel, some are perpendicular to each other and some are inclined as shown in Fig.1.

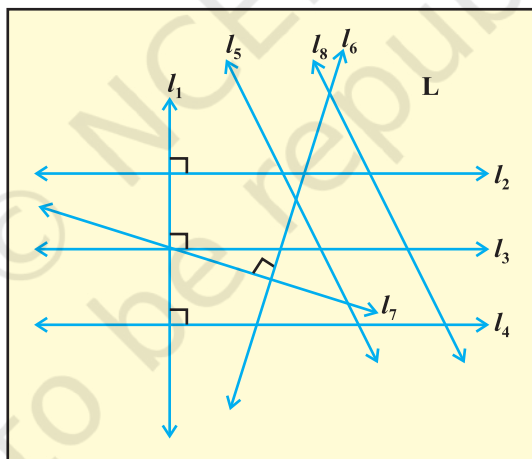

Fig. 1

DEMONSTRATION

1. Let the wires represent the lines l_1, l_2, \dots, l_8 .
2. l_1 is perpendicular to each of the lines l_2, l_3, l_4 . [see Fig. 1]

3. l_6 is perpendicular to l_7 .
4. l_2 is parallel to l_3 , l_3 is parallel to l_4 and l_5 is parallel to l_8 .
5. $(l_1, l_2), (l_1, l_3), (l_1, l_4), (l_6, l_7) \in R$

OBSERVATION

1. In Fig. 1, no line is perpendicular to itself, so the relation $R = \{(l, m) : l \perp m\}$ _____ reflexive (is/is not).
2. In Fig. 1, $l_1 \perp l_2$. Is $l_2 \perp l_1$? _____ (Yes/No)

$$\therefore (l_1, l_2) \in R \Rightarrow (l_2, l_1) \text{ _____ } R \quad (\notin/\in)$$

Similarly, $l_3 \perp l_1$. Is $l_1 \perp l_3$? _____ (Yes/No)

$$\therefore (l_3, l_1) \in R \Rightarrow (l_1, l_3) \text{ _____ } R \quad (\notin/\in)$$

Also, $l_6 \perp l_7$. Is $l_7 \perp l_6$? _____ (Yes/No)

$$\therefore (l_6, l_7) \in R \Rightarrow (l_7, l_6) \text{ _____ } R \quad (\notin/\in)$$

\therefore The relation R symmetric (is/is not)

3. In Fig. 1, $l_2 \perp l_1$ and $l_1 \perp l_3$. Is $l_2 \perp l_3$? ... (Yes/No)

$$\text{i.e., } (l_2, l_1) \in R \text{ and } (l_1, l_3) \in R \Rightarrow (l_2, l_3) \text{ _____ } R \quad (\notin/\in)$$

\therefore The relation R transitive (is/is not).

APPLICATION

This activity can be used to check whether a given relation is an equivalence relation or not.

NOTE

1. In this case, the relation is not an equivalence relation.
2. The activity can be repeated by taking some more wire in different positions.

Activity 2

OBJECTIVE

To verify that the relation R in the set L of all lines in a plane, defined by $R = \{(l, m) : l \parallel m\}$ is an equivalence relation.

MATERIAL REQUIRED

A piece of plywood, some pieces of wire (8), plywood, nails, white paper, glue.

METHOD OF CONSTRUCTION

Take a piece of plywood of convenient size and paste a white paper on it. Fix the wires randomly on the plywood with the help of nails such that some of them are parallel, some are perpendicular to each other and some are inclined as shown in Fig. 2.

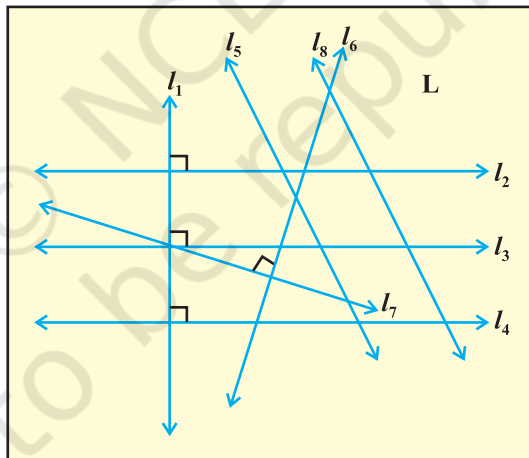

Fig. 2

DEMONSTRATION

1. Let the wires represent the lines l_1, l_2, \dots, l_8 .
2. l_1 is perpendicular to each of the lines l_2, l_3, l_4 (see Fig. 2).

3. l_6 is perpendicular to l_7 .
4. l_2 is parallel to l_3 , l_3 is parallel to l_4 and l_5 is parallel to l_8 .
5. $(l_2, l_3), (l_3, l_4), (l_5, l_8), \in R$

OBSERVATION

1. In Fig. 2, every line is parallel to itself. So the relation $R = \{(l, m) : l \parallel m\}$... reflexive relation (is/is not)
2. In Fig. 2, observe that $l_2 \parallel l_3$. Is $l_3 \dots l_2$? (\neq / \parallel)

So, $(l_2, l_3) \in R \Rightarrow (l_3, l_2) \dots R$ (\notin / \in)

Similarly, $l_3 \parallel l_4$. Is $l_4 \dots l_3$? (\neq / \parallel)

So, $(l_3, l_4) \in R \Rightarrow (l_4, l_3) \dots R$ (\notin / \in)

and $(l_5, l_8) \in R \Rightarrow (l_8, l_5) \dots R$ (\notin / \in)

\therefore The relation R ... symmetric relation (is/is not)

3. In Fig. 2, observe that $l_2 \parallel l_3$ and $l_3 \parallel l_4$. Is $l_2 \dots l_4$? (\parallel / \parallel)

So, $(l_2, l_3) \in R$ and $(l_3, l_4) \in R \Rightarrow (l_2, l_4) \dots R$ (\in / \notin)

Similarly, $l_3 \parallel l_4$ and $l_4 \parallel l_2$. Is $l_3 \dots l_2$? (\neq / \parallel)

So, $(l_3, l_4) \in R, (l_4, l_2) \in R \Rightarrow (l_3, l_2) \dots R$ (\in, \notin)

Thus, the relation R ... transitive relation (is/is not)

Hence, the relation R is reflexive, symmetric and transitive. So, R is an equivalence relation.

APPLICATION

This activity is useful in understanding the concept of an equivalence relation.

NOTE

This activity can be repeated by taking some more wires in different positions.

Activity 3

OBJECTIVE

To demonstrate a function which is not one-one but is onto.

MATERIAL REQUIRED

Cardboard, nails, strings, adhesive and plastic strips.

METHOD OF CONSTRUCTION

1. Paste a plastic strip on the left hand side of the cardboard and fix three nails on it as shown in the Fig.3.1. Name the nails on the strip as 1, 2 and 3.
2. Paste another strip on the right hand side of the cardboard and fix two nails in the plastic strip as shown in Fig.3.2. Name the nails on the strip as a and b .
3. Join nails on the left strip to the nails on the right strip as shown in Fig. 3.3.

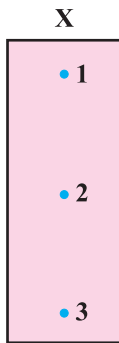

Fig. 3.1



Fig. 3.2

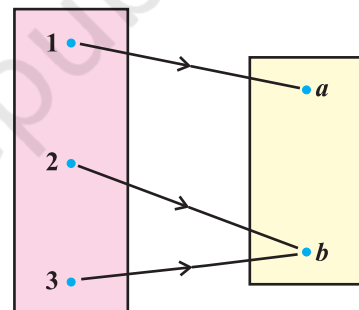

Fig. 3.3

DEMONSTRATION

1. Take the set $X = \{1, 2, 3\}$
2. Take the set $Y = \{a, b\}$
3. Join (correspondence) elements of X to the elements of Y as shown in Fig. 3.3

OBSERVATION

1. The image of the element 1 of X in Y is _____.

The image of the element 2 of X in Y is _____.

The image of the element 3 of X in Y is _____.

So, Fig. 3.3 represents a _____ .

2. Every element in X has a _____ image in Y. So, the function is _____ (one-one/not one-one).
3. The pre-image of each element of Y in X _____ (exists/does not exist). So, the function is _____ (onto/not onto).

APPLICATION

This activity can be used to demonstrate the concept of one-one and onto function.

NOTE

Demonstrate the same activity by changing the number of the elements of the sets X and Y.

Activity 4

OBJECTIVE

To demonstrate a function which is one-one but not onto.

MATERIAL REQUIRED

Cardboard, nails, strings, adhesive and plastic strips.

METHOD OF CONSTRUCTION

1. Paste a plastic strip on the left hand side of the cardboard and fix two nails in it as shown in the Fig. 4.1. Name the nails as a and b .
2. Paste another strip on the right hand side of the cardboard and fix three nails on it as shown in the Fig. 4.2. Name the nails on the right strip as 1, 2 and 3.
3. Join nails on the left strip to the nails on the right strip as shown in the Fig. 4.3.

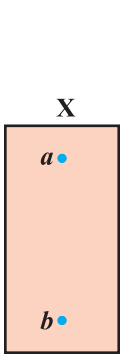

Fig. 4.1



Fig. 4.2

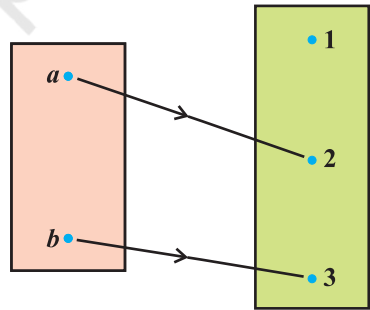

Fig. 4.3

DEMONSTRATION

1. Take the set $X = \{a, b\}$
2. Take the set $Y = \{1, 2, 3\}$.
3. Join elements of X to the elements of Y as shown in Fig. 4.3.

OBSERVATION

1. The image of the element a of X in Y is _____.

The image of the element b of X in Y is _____.

So, the Fig. 4.3 represents a _____.

2. Every element in X has a _____ image in Y . So, the function is _____ (one-one/not one-one).

3. The pre-image of the element 1 of Y in X _____ (exists/does not exist). So, the function is _____ (onto/not onto).

Thus, Fig. 4.3 represents a function which is _____ but not onto.

APPLICATION

This activity can be used to demonstrate the concept of one-one but not onto function.

Activity 5

OBJECTIVE

To draw the graph of $\sin^{-1} x$, using the graph of $\sin x$ and demonstrate the concept of mirror reflection (about the line $y = x$).

MATERIAL REQUIRED

Cardboard, white chart paper, ruler, coloured pens, adhesive, pencil, eraser, cutter, nails and thin wires.

METHOD OF CONSTRUCTION

1. Take a cardboard of suitable dimensions, say, 30 cm \times 30 cm.
2. On the cardboard, paste a white chart paper of size 25 cm \times 25 cm (say).
3. On the paper, draw two lines, perpendicular to each other and name them $X'OX$ and YOY' as rectangular axes [see Fig. 5].

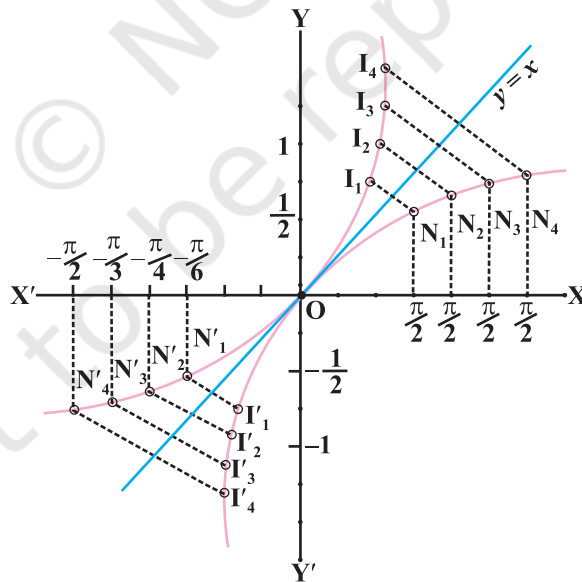

Fig. 5

4. Graduate the axes approximately as shown in Fig. 5.1 by taking unit on X-axis = 1.25 times the unit of Y-axis.

5. Mark approximately the points

$\left(\frac{\pi}{6}, \sin \frac{\pi}{6}\right), \left(\frac{\pi}{4}, \sin \frac{\pi}{4}\right), \dots, \left(\frac{\pi}{2}, \sin \frac{\pi}{2}\right)$ in the coordinate plane and at each point fix a nail.

6. Repeat the above process on the other side of the x -axis, marking the points

$\left(\frac{-\pi}{6}, \sin \frac{-\pi}{6}\right), \left(\frac{-\pi}{4}, \sin \frac{-\pi}{4}\right), \dots, \left(\frac{-\pi}{2}, \sin \frac{-\pi}{2}\right)$ approximately and fix nails on these points as N_1', N_2', N_3', N_4' . Also fix a nail at O.

7. Join the nails with the help of a tight wire on both sides of x -axis to get the

graph of $\sin x$ from $\frac{-\pi}{2}$ to $\frac{\pi}{2}$.

8. Draw the graph of the line $y = x$ (by plotting the points (1,1), (2, 2), (3, 3), ... etc. and fixing a wire on these points).

9. From the nails N_1, N_2, N_3, N_4 , draw perpendicular on the line $y = x$ and produce these lines such that length of perpendicular on both sides of the line $y = x$ are equal. At these points fix nails, I_1, I_2, I_3, I_4 .

10. Repeat the above activity on the other side of X- axis and fix nails at I_1', I_2', I_3', I_4' .

11. Join the nails on both sides of the line $y = x$ by a tight wire that will show the graph of $y = \sin^{-1} x$.

DEMONSTRATION

Put a mirror on the line $y = x$. The image of the graph of $\sin x$ in the mirror will represent the graph of $\sin^{-1} x$ showing that $\sin^{-1} x$ is mirror reflection of $\sin x$ and vice versa.

OBSERVATION

The image of point N_1 in the mirror (the line $y = x$) is _____.

The image of point N_2 in the mirror (the line $y = x$) is _____.

The image of point N_3 in the mirror (the line $y = x$) is _____.

The image of point N_4 in the mirror (the line $y = x$) is _____.

The image of point N'_1 in the mirror (the line $y = x$) is _____.

The image point of N'_2 in the mirror (the line $y = x$) is _____.

The image point of N'_3 in the mirror (the line $y = x$) is _____.

The image point of N'_4 in the mirror (the line $y = x$) is _____.

The image of the graph of $\sin x$ in $y = x$ is the graph of _____, and the image of the graph of $\sin^{-1}x$ in $y = x$ is the graph of _____.

APPLICATION

Similar activity can be performed for drawing the graphs of $\cos^{-1}x$, $\tan^{-1}x$, etc.

Activity 6

OBJECTIVE

To explore the principal value of the function $\sin^{-1}x$ using a unit circle.

MATERIAL REQUIRED

Cardboard, white chart paper, rails, ruler, adhesive, steel wires and needle.

METHOD OF CONSTRUCTION

1. Take a cardboard of a convenient size and paste a white chart paper on it.
2. Draw a unit circle with centre O on it.
3. Through the centre of the circle, draw two perpendicular lines $X'OX$ and YOY' representing x -axis and y -axis, respectively as shown in Fig. 6.1.
4. Mark the points A , C , B and D , where the circle cuts the x -axis and y -axis, respectively as shown in Fig. 6.1.
5. Fix two rails on opposite sides of the cardboard which are parallel to y -axis. Fix one steel wire between the rails such that the wire can be moved parallel to x -axis as shown in Fig. 6.2.

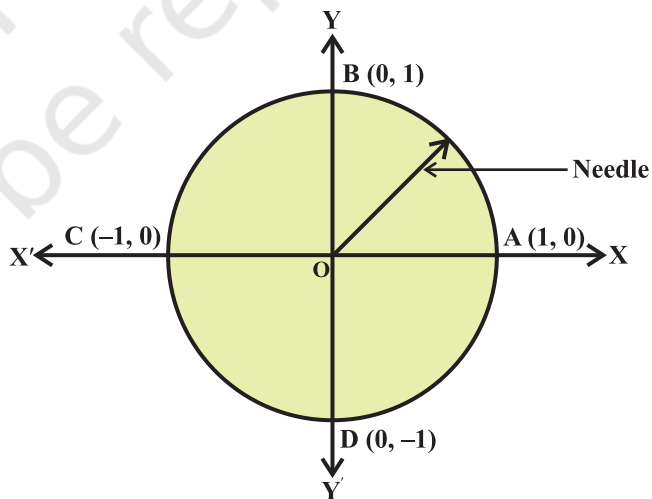

Fig. 6.1

6. Take a needle of unit length. Fix one end of it at the centre of the circle and the other end to move freely along the circle Fig. 6.2.

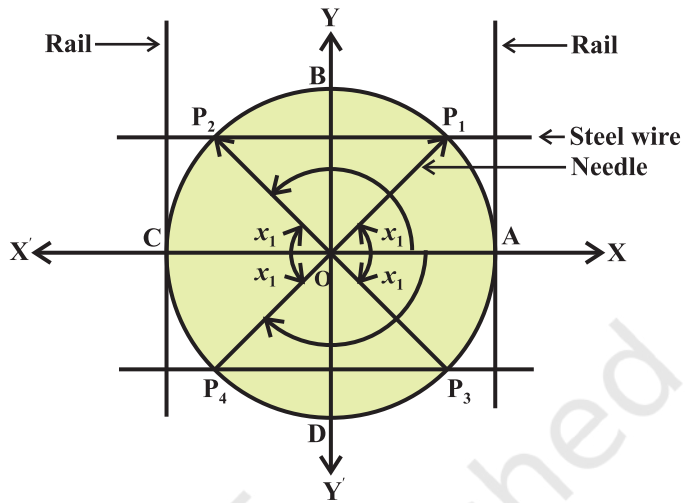

Fig. 6.2

DEMONSTRATION

1. Keep the needle at an arbitrary angle, say x_1 with the positive direction of x -axis. Measure of angle in radian is equal to the length of intercepted arc of the unit circle.
2. Slide the steel wire between the rails, parallel to x -axis such that the wire meets with free end of the needle (say P_1) (Fig. 6.2).
3. Denote the y -coordinate of the point P_1 as y_1 , where y_1 is the perpendicular distance of steel wire from the x -axis of the unit circle giving $y_1 = \sin x_1$.
4. Rotate the needle further anticlockwise and keep it at the angle $\pi - x_1$. Find the value of y -coordinate of intersecting point P_2 with the help of sliding steel wire. Value of y -coordinate for the points P_1 and P_2 are same for the different value of angles, $y_1 = \sin x_1$ and $y_1 = \sin(\pi - x_1)$. This demonstrates that sine function is not one-to-one for angles considered in first and second quadrants.
5. Keep the needle at angles $-x_1$ and $(-\pi + x_1)$, respectively. By sliding down the steel wire parallel to x -axis, demonstrate that y -coordinate for the points P_3 and P_4 are the same and thus sine function is not one-to-one for points considered in 3rd and 4th quadrants as shown in Fig. 6.2.

6. However, the y -coordinate of the points P_3 and P_1 are different. Move the needle in anticlockwise direction

starting from $-\frac{\pi}{2}$ to $\frac{\pi}{2}$ and

look at the behaviour of y -coordinates of points P_5 , P_6 , P_7 and P_8 by sliding the steel wire parallel to x -axis accordingly. y -coordinate of points P_5 , P_6 , P_7 and P_8 are different (see Fig. 6.3). Hence, sine function is one-to-one in

the domain $\left[-\frac{\pi}{2}, \frac{\pi}{2}\right]$ and its range lies between -1 and 1 .

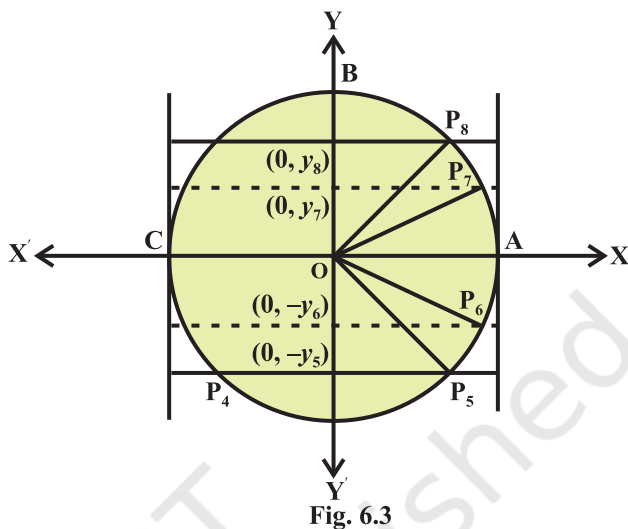

Fig. 6.3

7. Keep the needle at any arbitrary angle say θ lying in the interval $\left[-\frac{\pi}{2}, \frac{\pi}{2}\right]$

and denote the y -coordinate of the intersecting point P_9 as y . (see Fig. 6.4). Then $y = \sin \theta$ or $\theta = \arcsin y$ as sine function is one-one and onto in the

domain $\left[-\frac{\pi}{2}, \frac{\pi}{2}\right]$ and range $[-1, 1]$. So, its inverse arc sine function exist. The domain of arc sine function is $[-1, 1]$ and

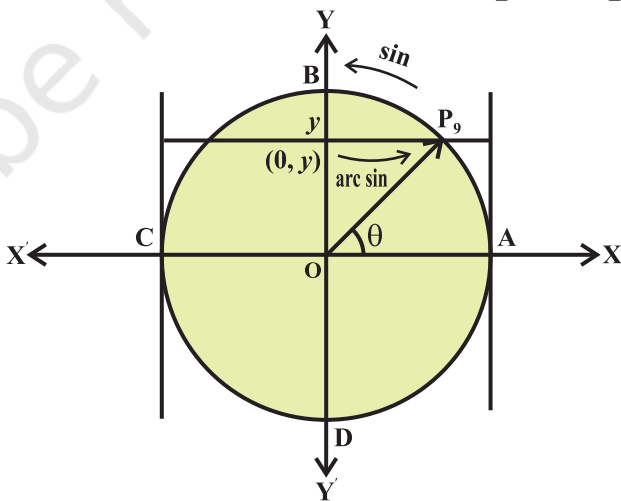

Fig. 6.4

range is $\left[-\frac{\pi}{2}, \frac{\pi}{2}\right]$. This range is called the principal value of arc sine function (or \sin^{-1} function).

OBSERVATION

1. sine function is non-negative in _____ and _____ quadrants.
2. For the quadrants 3rd and 4th, sine function is _____.
3. $\theta = \arcsin y \Rightarrow y = \sin \theta$ where $-\frac{\pi}{2} \leq \theta \leq \frac{\pi}{2}$.
4. The other domains of sine function on which it is one-one and onto provides _____ for arc sine function.

APPLICATION

This activity can be used for finding the principal value of arc cosine function ($\cos^{-1}y$).

Activity 7

OBJECTIVE

To sketch the graphs of a^x and $\log_a x$, $a > 0$, $a \neq 1$ and to examine that they are mirror images of each other.

MATERIAL REQUIRED

Drawing board, geometrical instruments, drawing pins, thin wires, sketch pens, thick white paper, adhesive, pencil, eraser, a plane mirror, squared paper.

METHOD OF CONSTRUCTION

1. On the drawing board, fix a thick paper sheet of convenient size 20 cm \times 20 cm (say) with adhesive.

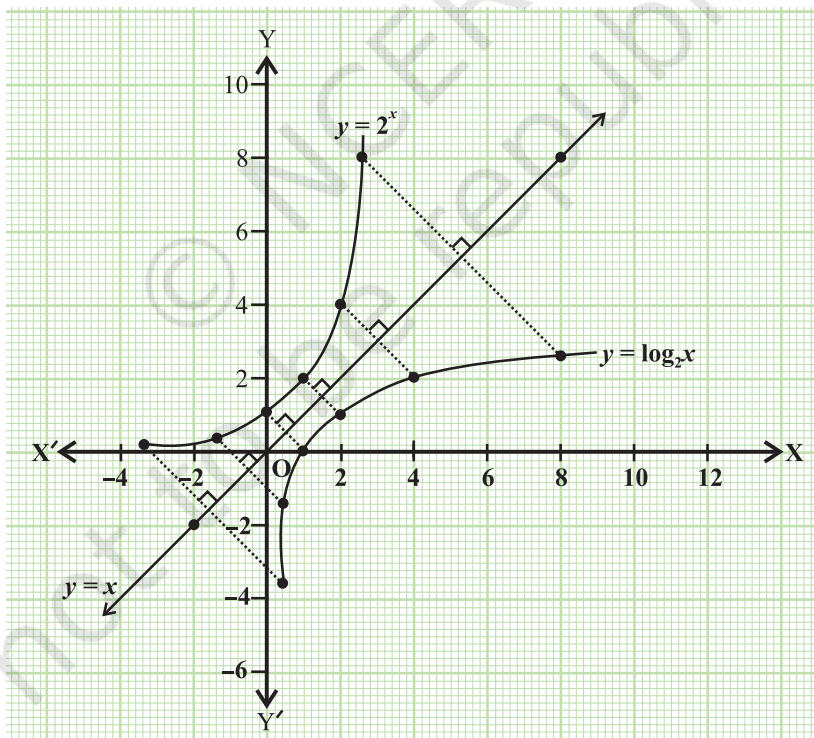

Fig. 7

- On the sheet, take two perpendicular lines XOX' and YOY' , depicting coordinate axes.
- Mark graduations on the two axes as shown in the Fig. 7.
- Find some ordered pairs satisfying $y = a^x$ and $y = \log_a x$. Plot these points corresponding to the ordered pairs and join them by free hand curves in both the cases. Fix thin wires along these curves using drawing pins.
- Draw the graph of $y = x$, and fix a wire along the graph, using drawing pins.

DEMONSTRATION

- For a^x , take $a = 2$ (say), and find ordered pairs satisfying it as

x	0	1	-1	2	-2	3	-3	$\frac{1}{2}$	$-\frac{1}{2}$	4
2^x	1	2	0.5	4	$\frac{1}{4}$	8	$\frac{1}{8}$	1.4	0.7	16

and plot these ordered pairs on the squared paper and fix a drawing pin at each point.

- Join the bases of drawing pins with a thin wire. This will represent the graph of 2^x .
- $\log_2 x = y$ gives $x = 2^y$. Some ordered pairs satisfying it are:

x	1	2	$\frac{1}{2}$	4	$\frac{1}{4}$	8	$\frac{1}{8}$
y	0	1	-1	2	-2	3	-3

Plot these ordered pairs on the squared paper (graph paper) and fix a drawing pin at each plotted point. Join the bases of the drawing pins with a thin wire. This will represent the graph of $\log_2 x$.

4. Draw the graph of line $y = x$ on the sheet.
5. Place a mirror along the wire representing $y = x$. It can be seen that the two graphs of the given functions are mirror images of each other in the line $y = x$.

OBSERVATION

1. Image of ordered pair $(1, 2)$ on the graph of $y = 2^x$ in $y = x$ is _____. It lies on the graph of $y =$ _____.
2. Image of the point $(4, 2)$ on the graph $y = \log_2 x$ in $y = x$ is _____ which lies on the graph of $y =$ _____.

Repeat this process for some more points lying on the two graphs.

APPLICATION

This activity is useful in understanding the concept of (exponential and logarithmic functions) which are mirror images of each other in $y = x$.

Activity 8

OBJECTIVE

To establish a relationship between common logarithm (to the base 10) and natural logarithm (to the base e) of the number x .

MATERIAL REQUIRED

Hardboard, white sheet, graph paper, pencil, scale, log tables or calculator (graphic/scientific).

METHOD OF CONSTRUCTION

1. Paste a graph paper on a white sheet and fix the sheet on the hardboard.
2. Find some ordered pairs satisfying the function $y = \log_{10} x$. Using log tables/calculator and draw the graph of the function on the graph paper (see Fig. 8)

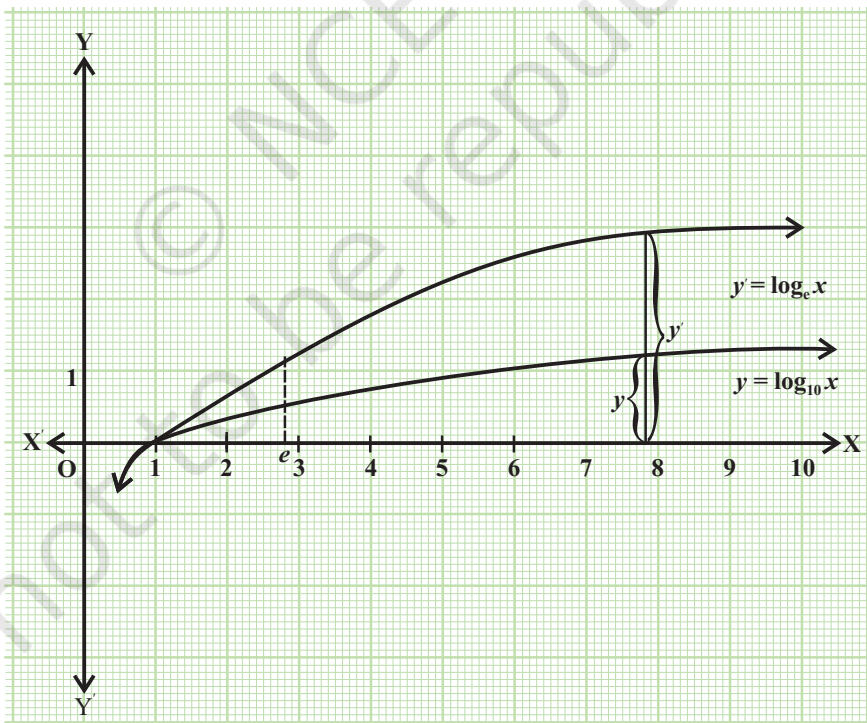

Fig. 8

- Similarly, draw the graph of $y' = \log_e x$ on the same graph paper as shown in the figure (using log table/calculator).

DEMONSTRATION

- Take any point on the positive direction of x -axis, and note its x -coordinate.
- For this value of x , find the value of y -coordinates for both the graphs of $y = \log_{10} x$ and $y' = \log_e x$ by actual measurement, using a scale, and record them as y and y' , respectively.
- Find the ratio $\frac{y}{y'}$.
- Repeat the above steps for some more points on the x -axis (with different values) and find the corresponding ratios of the ordinates as in Step 3.
- Each of these ratios will nearly be the same and equal to 0.4, which is

approximately equal to $\frac{1}{\log_e 10}$.

OBSERVATION

S.No.	Points on the x -axis	$y = \log_{10} x$	$y' = \log_e x$	Ratio $\frac{y}{y'}$ (approximate)
1.	$x_1 = \text{-----}$	$y_1 = \text{-----}$	$y'_1 = \text{-----}$	-----
2.	$x_2 = \text{-----}$	$y_2 = \text{-----}$	$y'_2 = \text{-----}$	-----
3.	$x_3 = \text{-----}$	$y_3 = \text{-----}$	$y'_3 = \text{-----}$	-----
4.	$x_4 = \text{-----}$	$y_4 = \text{-----}$	$y'_4 = \text{-----}$	-----
5.	$x_5 = \text{-----}$	$y_5 = \text{-----}$	$y'_5 = \text{-----}$	-----
6.	$x_6 = \text{-----}$	$y_6 = \text{-----}$	$y'_6 = \text{-----}$	-----

2. The value of $\frac{y}{y'}$ for each point x is equal to _____ approximately.

3. The observed value of $\frac{y}{y'}$ in each case is approximately equal to the value of

$$\frac{1}{\log_e 10} \cdot (\text{Yes/No})$$

4. Therefore, $\log_{10} x = \frac{\log_e x}{\log_e 10}$.

APPLICATION

This activity is useful in converting log of a number in one given base to log of that number in another base.

NOTE

Let, $y = \log_{10} x$, i.e., $x = 10^y$.

Taking logarithm to base e on both the sides, we get $\log_e x = y \log_e 10$

$$\text{or } y = \frac{1}{\log_e 10} (\log_e x)$$

$$\Rightarrow \frac{\log_{10} x}{\log_e x} = \frac{1}{\log_e 10} = 0.434294 \text{ (using log tables/calculator).}$$

Activity 9

OBJECTIVE

To find analytically the limit of a function $f(x)$ at $x = c$ and also to check the continuity of the function at that point.

MATERIAL REQUIRED

Paper, pencil, calculator.

METHOD OF CONSTRUCTION

1. Consider the function given by $f(x) = \begin{cases} \frac{x^2 - 16}{x - 4}, & x \neq 4 \\ 10, & x = 4 \end{cases}$
2. Take some points on the left and some points on the right side of $c (= 4)$ which are very near to c .
3. Find the corresponding values of $f(x)$ for each of the points considered in step 2 above.
4. Record the values of points on the left and right side of c as x and the corresponding values of $f(x)$ in a form of a table.

DEMONSTRATION

1. The values of x and $f(x)$ are recorded as follows:

Table 1 : For points on the left of $c (= 4)$.

x	3.9	3.99	3.999	3.9999	3.99999	3.999999	3.9999999
$f(x)$	7.9	7.99	7.999	7.9999	7.99999	7.999999	7.9999999

2. **Table 2:** For points on the right of $c (= 4)$.

x	4.1	4.01	4.001	4.0001	4.00001	4.000001	4.0000001
$f(x)$	8.1	8.01	8.001	8.0001	8.00001	8.000001	8.0000001

OBSERVATION

1. The value of $f(x)$ is approaching to _____, as $x \rightarrow 4$ from the left.
2. The value of $f(x)$ is approaching to _____, as $x \rightarrow 4$ from the right.
3. So, $\lim_{x \rightarrow 4^-} f(x) =$ _____ and $\lim_{x \rightarrow 4^+} f(x) =$ _____.
4. Therefore, $\lim_{x \rightarrow 4} f(x) =$ _____, $f(4) =$ _____.
5. Is $\lim_{x \rightarrow 4} f(x) = f(4)$ _____? (Yes/No)
6. Since $f(c) \neq \lim_{x \rightarrow c} f(x)$, so, the function is _____ at $x = 4$ (continuous/not continuous).

APPLICATION

This activity is useful in understanding the concept of limit and continuity of a function at a point.

Activity 10

OBJECTIVE

To verify that for a function f to be continuous at given point x_0 ,

$$\Delta y = |f(x_0 + \Delta x) - f(x_0)|$$

is arbitrarily small provided Δx is sufficiently small.

MATERIAL REQUIRED

Hardboard, white sheets, pencil, scale, calculator, adhesive.

METHOD OF CONSTRUCTION

1. Paste a white sheet on the hardboard.
2. Draw the curve of the given continuous function as represented in the Fig. 10.
3. Take any point A ($x_0, 0$) on the positive side of x -axis and corresponding to this point, mark the point P (x_0, y_0) on the curve.

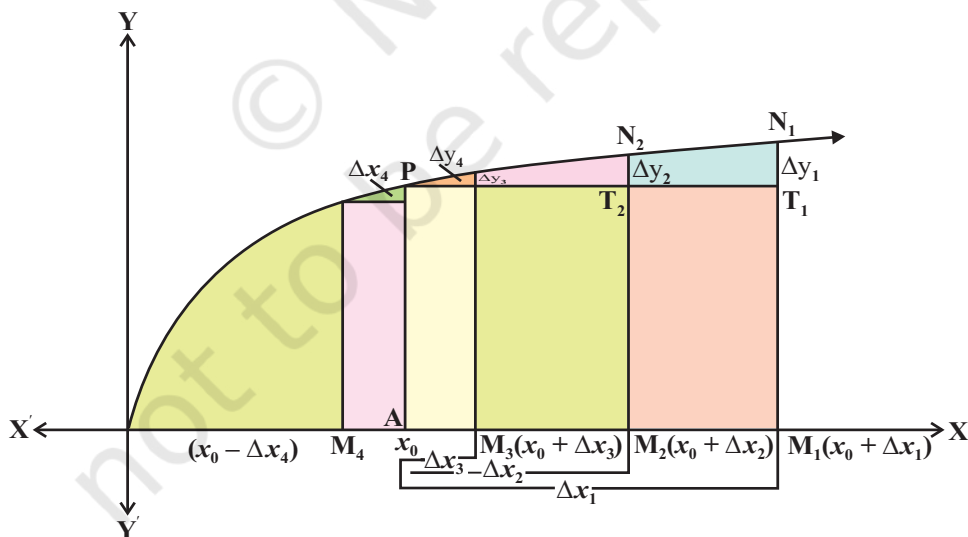

Fig. 10

DEMONSTRATION

1. Take one more point $M_1 (x_0 + \Delta x_1, 0)$ to the right of A, where Δx_1 is an increment in x .
2. Draw the perpendicular from M_1 to meet the curve at N_1 . Let the coordinates of N_1 be $(x_0 + \Delta x_1, y_0 + \Delta y_1)$
3. Draw a perpendicular from the point P (x_0, y_0) to meet N_1M_1 at T_1 .
4. Now measure $AM_1 = \Delta x_1$ (say) and record it and also measure $N_1T_1 = \Delta y_1$ and record it.
5. Reduce the increment in x to Δx_2 (i.e., $\Delta x_2 < \Delta x_1$) to get another point $M_2 (x_0 + \Delta x_2, 0)$. Get the corresponding point N_2 on the curve
6. Let the perpendicular PT_1 intersects N_2M_2 at T_2 .
7. Again measure $AM_2 = \Delta x_2$ and record it.
Measure $N_2T_2 = \Delta y_2$ and record it.
8. Repeat the above steps for some more points so that Δx becomes smaller and smaller.

OBSERVATION

S.No.	Value of increment in x_0	Corresponding increment in y
1.	$ \Delta x_1 =$ _____	$ \Delta y_1 =$ _____
2.	$ \Delta x_2 =$ _____	$ \Delta y_2 =$ _____
3.	$ \Delta x_3 =$ _____	$ \Delta y_3 =$ _____
4.	$ \Delta x_4 =$ _____	$ \Delta y_4 =$ _____
5.	$ \Delta x_5 =$ _____	$ \Delta y_5 =$ _____

6.	$ \Delta x_6 =$	$ \Delta y_6 =$
7.	$ \Delta x_7 =$	$ \Delta y_7 =$
8.	$ \Delta x_8 =$	$ \Delta y_8 =$
9.	$ \Delta x_9 =$	$ \Delta y_9 =$

2. So, Δy becomes _____ when Δx becomes smaller.

3. Thus $\lim_{\Delta x \rightarrow 0} \Delta y = 0$ for a continuous function.

APPLICATION

This activity is helpful in explaining the concept of derivative (left hand or right hand) at any point on the curve corresponding to a function.