

### Multiple Choice Questions I

2.1. A capacitor of  $4\mu\text{F}$  is connected as shown in the circuit. The internal resistance of the battery is  $0.5\Omega$ . The amount of charge on the capacitor plates will be

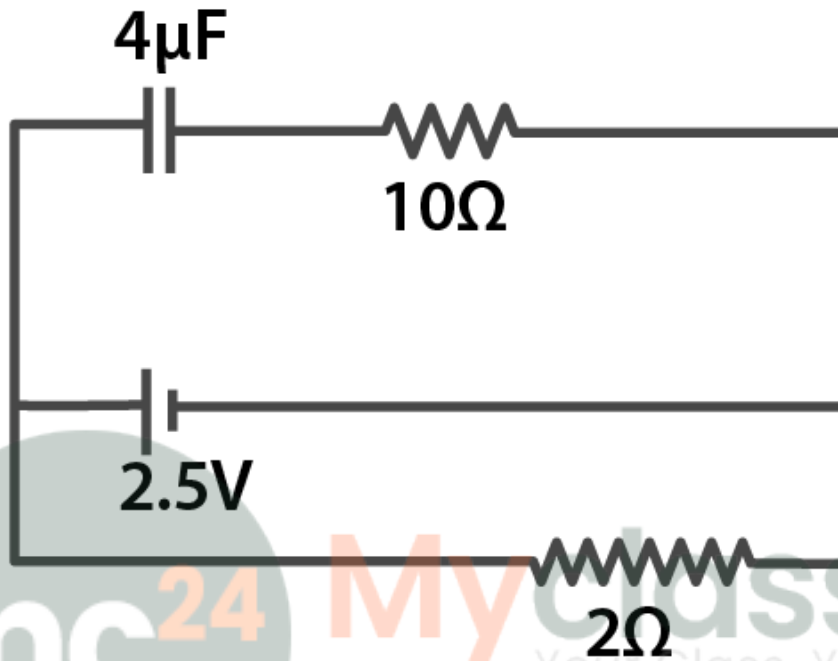

- a) 0
- b)  $4\mu\text{C}$
- c)  $16\mu\text{C}$
- d)  $8\mu\text{C}$

Answer:

The correct answer is d)  $8\mu\text{C}$

2.2. A positively charged particle is released from rest in a uniform electric field. The electric potential energy of the charge

- a) remains a constant because the electric field is uniform
- b) increases because the charge moves along the electric field
- c) decreases because the charge moves along the electric field
- d) decreases because the charge moves opposite to the electric field

Answer:

The correct answer is c) decreases because the charge moves along the electric field

2.3. Figure shows some equipotential lines distributed in space. A charged object is moved from point A to point B.

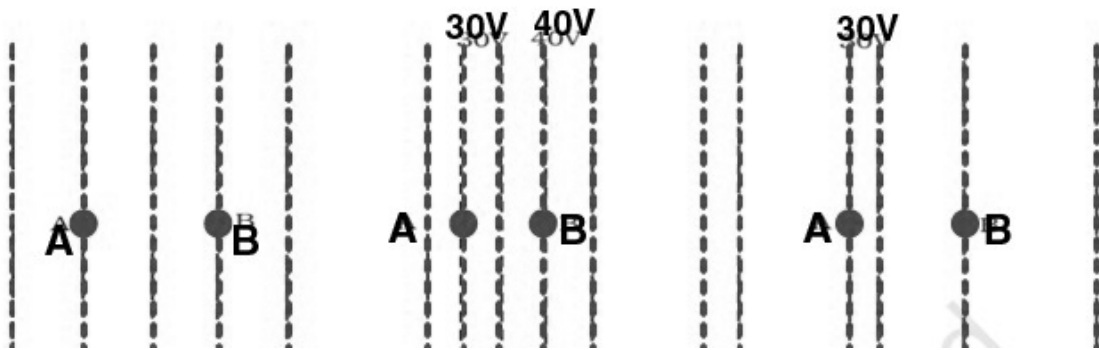

- a) the work done in fig (i) is the greatest
- b) the work done in fig (ii) is least
- c) the work done is the same in fig (i), fig (ii), and fig (iii)
- d) the work done in fig (iii) is greater than fig (ii) but equal to that in fig (i)

Answer:

The correct answer is c) the work done is the same in fig (i), fig (ii), and fig (iii)

2.4. The electrostatic potential on the surface of a charged conducting sphere is 100V. Two statements are made in this regard:

S<sub>1</sub>: At any point inside the sphere, electric intensity is zero

S<sub>2</sub>: At any point inside the sphere, the electrostatic potential is 100V

Which of the following is a correct statement?

- a) S<sub>1</sub> is true but S<sub>2</sub> is false
- b) Both S<sub>1</sub> and S<sub>2</sub> are false
- c) S<sub>1</sub> is true, S<sub>2</sub> is also true, and S<sub>1</sub> is the cause of S<sub>2</sub>
- d) S<sub>1</sub> is true, S<sub>2</sub> is also true but the statements are independent

Answer:

The correct answer is c) S<sub>1</sub> is true, S<sub>2</sub> is also true, and S<sub>1</sub> is the cause of S<sub>2</sub>

2.5. Equipotential at a great distance from a collection of charges whose total sum is not zero are approximately

- a) spheres
- b) planes
- c) paraboloids
- d) ellipsoids

Answer:

The correct answer is a) spheres

2.6. A parallel plate capacitor is made of two dielectric blocks in series. One of the blocks has thickness  $d_1$  and dielectric constant  $k_1$  and the other has thickness  $d_2$  and dielectric constant  $k_2$  as shown in the figure.

This arrangement can be thought as a dielectric slab of thickness  $d = d_1 + d_2$  and effective dielectric constant  $k$ . The  $k$  is

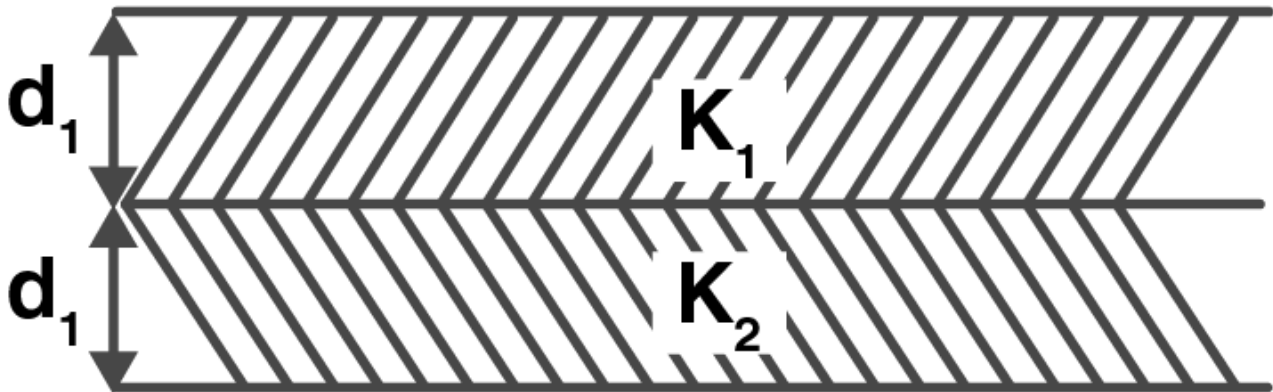

- a)  $k_1 d_1 + k_2 d_2 / d_1 + d_2$
- b)  $k_1 d_1 + k_2 d_2 / k_1 + k_2$
- c)  $k_1 k_2 (d_1 + d_2) / (k_1 d_1 + k_2 d_2)$
- d)  $2k_1 k_2 / k_1 + k_2$

Answer:

The correct answer is c)  $k_1 k_2 (d_1 + d_2) / (k_1 d_1 + k_2 d_2)$

### Multiple Choice Questions II

2.7. Consider a uniform electric field in the  $z$  direction. The potential is a constant

- a) in all space
- b) for any  $x$  for a given  $z$
- c) for any  $y$  for a given  $z$
- d) on the  $x$ - $y$  plane for a given  $z$

Answer:

The correct answer is

- b) for any  $x$  for a given  $z$
- c) for any  $y$  for a given  $z$
- d) on the  $x$ - $y$  plane for a given  $z$

2.8. Equipotential surfaces

- a) are closer in regions of large electric fields compared to regions of lower electric fields
- b) will be more crowded near sharp edges of a conductor
- c) will be more crowded near regions of large charge densities
- d) will always be equally spaced

**Answer:**

The correct answer is

- a) are closer in regions of large electric fields compared to regions of lower electric fields
- b) will be more crowded near sharp edges of a conductor
- c) will be more crowded near regions of large charge densities

**2.9. The work done to move a charge along an equipotential from A to B**

$$-\int_A^B E \cdot dl$$

a) cannot be defined as

$$-\int_A^B E \cdot dl$$

b) must be defined as

c) is zero

d) can have a non-zero value

**Answer:**

The correct answer is

$$-\int_A^B E \cdot dl$$

b) must be defined as

c) is zero

**2.10. In a region of constant potential**

a) the electric field is uniform

b) the electric field is zero

c) there can be no charge inside the region

d) the electric field shall necessarily change if a charge is placed outside the region

**Answer:**

The correct answer is

b) the electric field is zero

c) there can be no charge inside the region

**2.11. In the circuit shown in figure, initially key  $K_1$  is closed and  $K_2$  is open. Then  $K_1$  is opened and  $K_2$  is closed. Then**

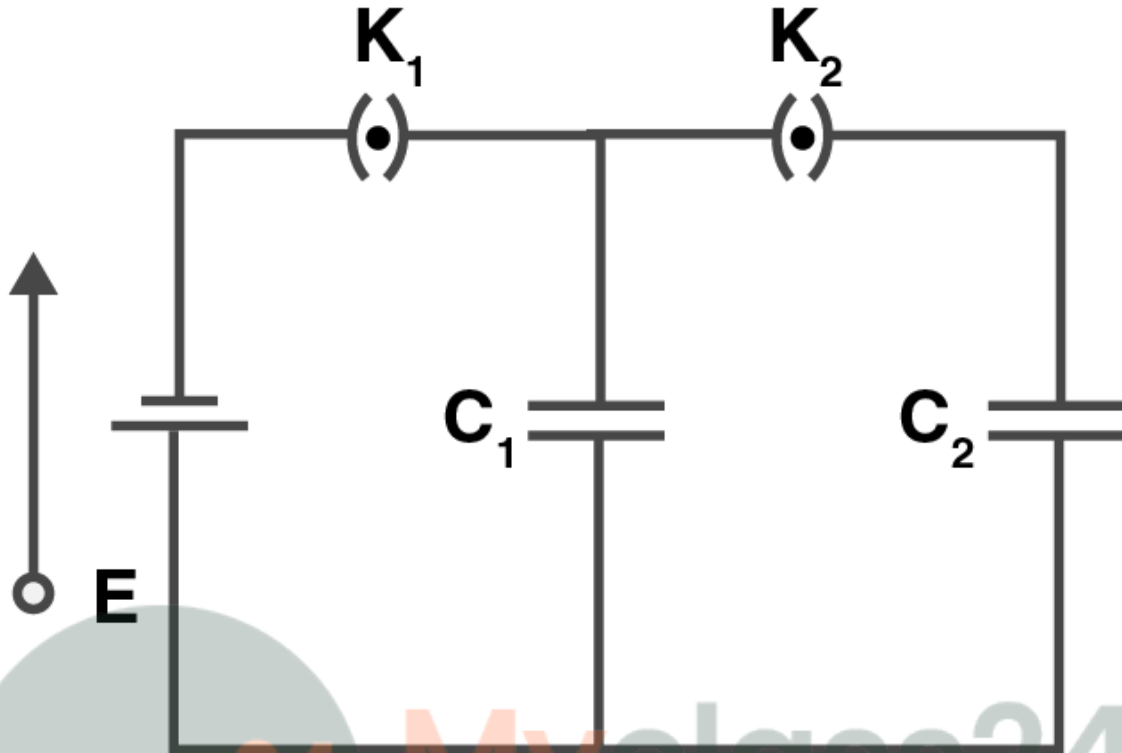

- a) charge on  $C_1$  gets redistributed such that  $V_1 = V_2$
- b) charge on  $C_1$  gets redistributed such that  $Q_1' = Q_2'$
- c) charge on  $C_1$  gets redistributed such that  $C_1V_1 + C_2V_2 = C_1E$
- d) charge on  $C_1$  gets redistributed such that  $Q_1' + Q_2' = Q$

**Answer:**

The correct answer is

- a) charge on  $C_1$  gets redistributed such that  $V_1 = V_2$
- d) charge on  $C_1$  gets redistributed such that  $Q_1' + Q_2' = Q$

**2.12. If a conductor has a potential  $V \neq 0$  and there are no charges anywhere else outside, then**

- a) there must be charges on the surface or inside itself
- b) there cannot be any charge in the body of the conductor
- c) there must be charges only on the surface
- d) there must be charges inside the surface

**Answer:**

The correct answer is

- a) there must be charges on the surface or inside itself
- b) there cannot be any charge in the body of the conductor

**2.13. A parallel plate capacitor is connected to a battery as shown in the figure. Consider two situations:**

**A: Key K is kept closed and plates of capacitors are moved apart using insulating handle**

**B: Key K is opened and plates of capacitors are moved apart using insulating handle**

Choose the correct options

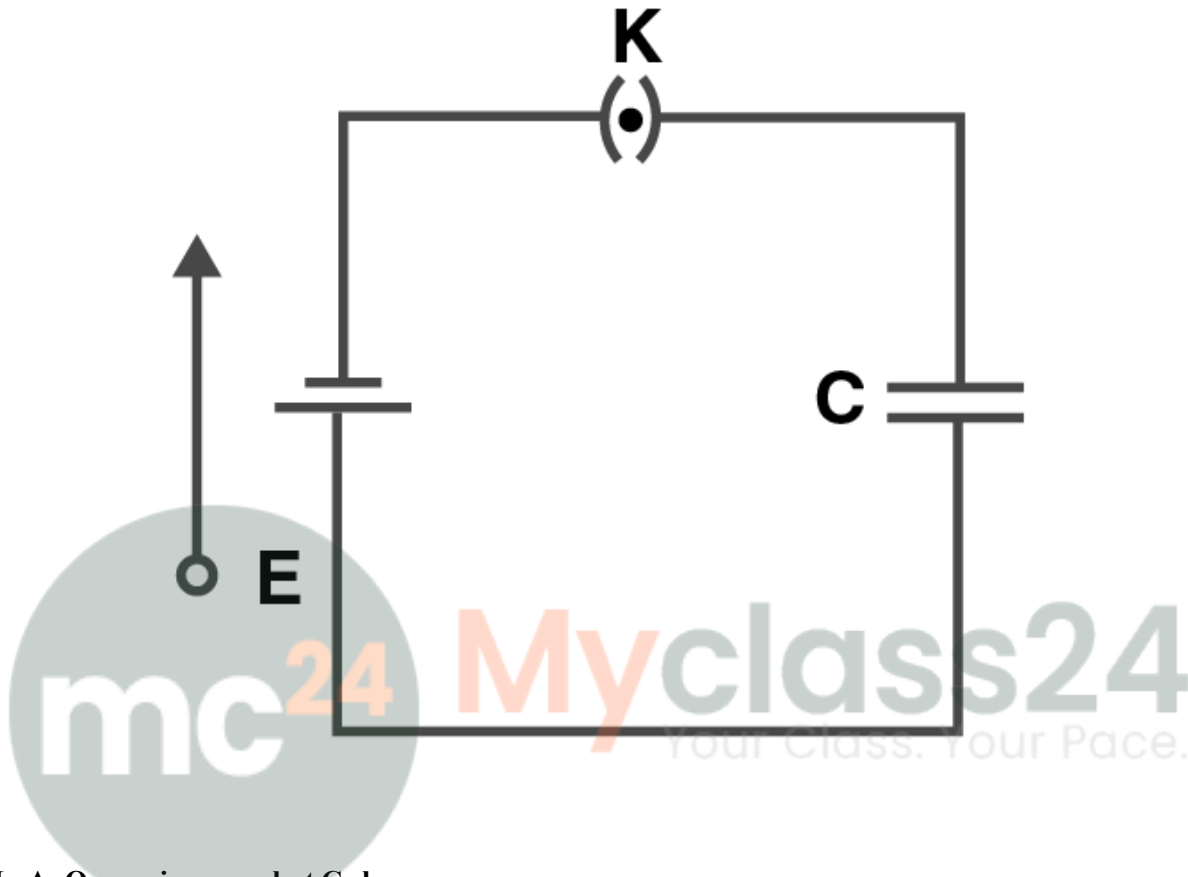

- a) In A:  $Q$  remains same but  $C$  changes
- b) In B:  $V$  remains same but  $C$  changes
- c) In A:  $V$  remains same and hence  $Q$  changes
- d) In B:  $Q$  remains same and hence  $V$  changes

Answer:

The correct answer is

- c) In A:  $V$  remains same and hence  $Q$  changes
- d) In B:  $Q$  remains same and hence  $V$  changes

### Very Short Answers

2.14. Consider two conducting spheres of radii  $R_1$  and  $R_2$  with  $R_1 > R_2$ . If the two are at the same potential, the larger sphere has more charge than the smaller sphere. State whether the charge density of the smaller sphere is more or less than that of the larger one.

Answer:

There are two spheres

$$\frac{1}{4\pi\epsilon_0} \frac{q_1}{R_1}$$

$$\frac{1}{4\pi\epsilon_0} \frac{q_2}{R_2}$$

$$\sigma_1 R_1 = \sigma_2 R_2$$

$$\sigma_1 / \sigma_2 = R_2 / R_1$$

As  $R_2 > R_1$ , that means  $\sigma_1 > \sigma_2$

Therefore, the charge density of the smaller sphere is more than that of the larger sphere.

**2.15. Do free electrons travel to region of higher potential or lower potential?**

**Answer:**

The force on the charge particle in electric field is  $F = qE$

The direction of electric field and the direction of electrostatic force experienced by the free electrons are in opposite directions

The direction of electric field is higher than the potential and therefore, the electrons travel from a lower potential region to higher potential.

**2.16. Can there be a potential difference between two adjacent conductors carrying the same charge?**

**Answer:**

Yes, there can be a potential difference between two adjacent conductors carrying same charge.

**2.17. Can the potential function have a maximum or minimum in free space?**

**Answer:**

No, potential function cannot be maximum or minimum in free space as the absence of atmosphere around the conductor prevents the electric discharge.

**2.18. A test charge  $q$  is made to move in the electric field of a point charge  $Q$  along two different closed paths. First path has sections along and perpendicular to lines of electric field, second path is a rectangular loop of the same area as the first loop. How does the work done compare in the two cases?**

**Answer:**

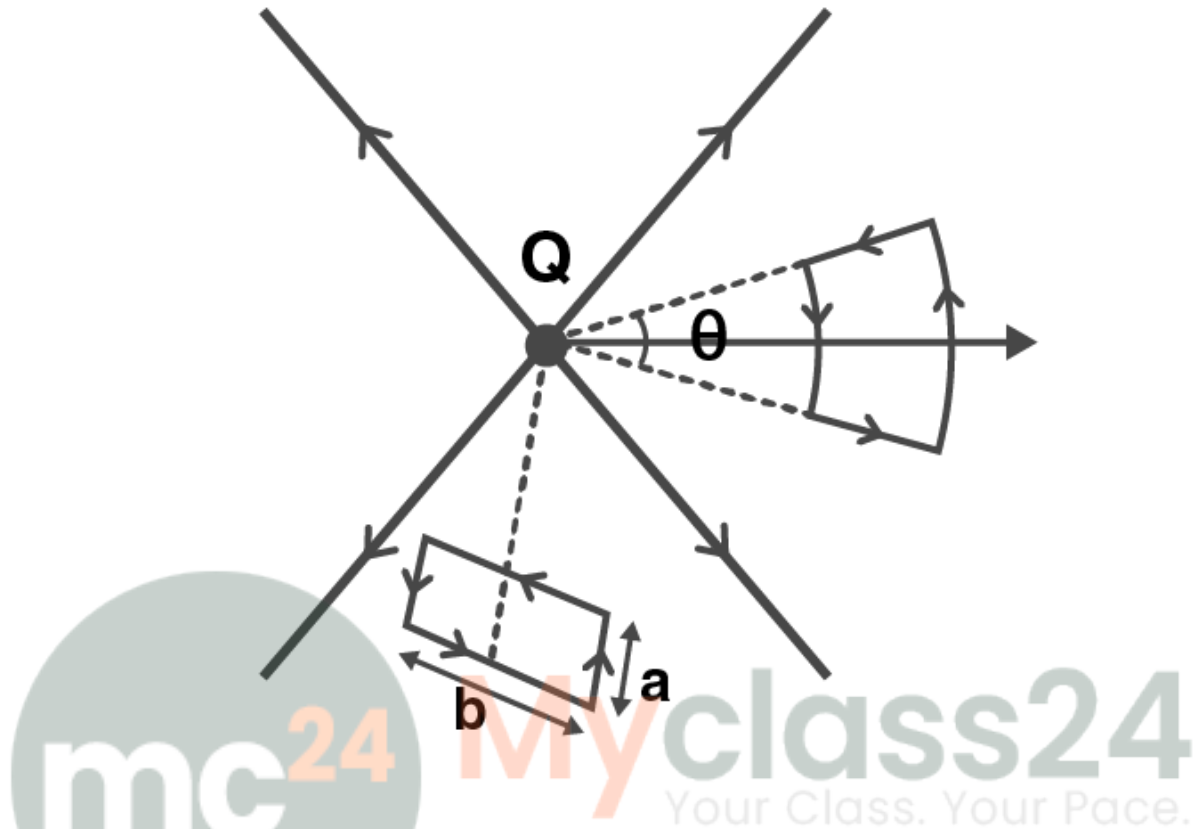

Work done is zero in both the cases. The work done by the electric force on the charge is in the closed loop which is equal to zero.

### Short Answers

**2.19. Prove that a closed equipotential surface with no charge within itself must enclose an equipotential volume.**

**Answer:**

In a closed equipotential surface, the potential changes from position to position.

The potential inside the surface is different from the potential gradient caused in the surface that is  $dV/dr$

This also means that electric field is not equal to zero and it is given as  $E = -dV/dr$

Therefore, it could be said that the field lines are either pointing inwards or outwards the surface.

So, it can be said that the field lines originate from the charges inside which contradicts the original assumption.

Therefore, the volume inside the surface must be equipotential.

**2.20. A capacitor has some dielectric between its plates, and the capacitor is connected to a DC source. The battery is now disconnected and then the dielectric is removed. State whether the capacitance, the energy stored in it, electric field, charge stored, and the voltage will increase, decrease, or remain constant.**

**Answer:**

Quantity	Battery is removed	Battery remains connected
----------	--------------------	---------------------------

## Class 12 Physics Chapter 2- Electrostatic Potential and Capacitance

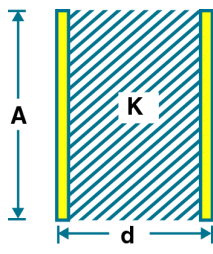
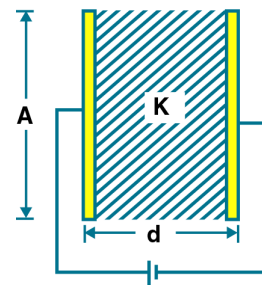
		
<b>Capacity</b>	$C' = KC$	$C' = KC$
<b>Charge</b>	$Q' = Q$	$Q' = KQ$
<b>Potential</b>	$V' = V/K$	$V' = V$
<b>Intensity</b>	$E' = E/K$	$E' = E$
<b>Energy</b>	$U' = U/K$	$U' = UK$

**2.21. Prove that, if an insulated, uncharged conductor is placed near a charged conductor and no other conductors are present, the uncharged body must be intermediate in potential between that of the charged body and that of infinity.**

**Answer:**

The electric potential decreasing along the direction of electric field is given as:  $E = dV/dr$

The electric potential decreases when the path from the charged conductor is taken to the uncharged conductor along the direction of electric field.

This continues when another uncharged conductor is consider to the infinity lowering the potential even further.

This shows that the uncharged body is at intermediate potential and the charged body is at infinity potential.

**2.22. Calculate potential energy of a point charge  $-q$  placed along the axis due to charge  $+Q$  uniformly distributed along a ring of radius  $R$ . Sketch PE as a function of axial distance  $z$  from the centre of the ring. Looking at graph, can you see what would happen if  $-q$  is displaced slightly from the centre of the ring?**

**Answer:**

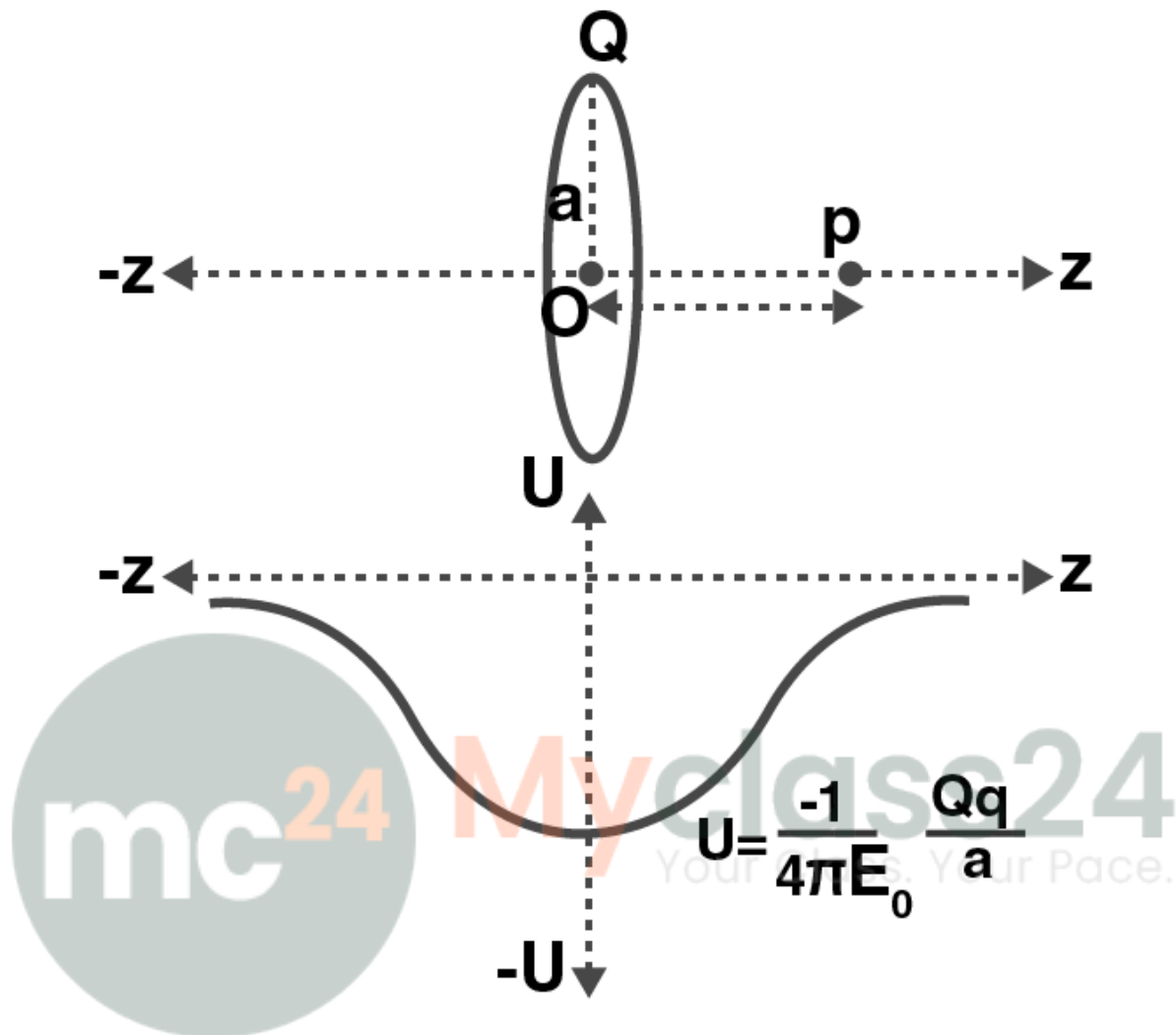

$U$  is the potential energy of a point charge  $q$  which is placed at potential  $V$ ,  $U = qV$

A negative charged particle is placed at the axis of the ring with charge  $Q$

Let  $a$  be the radius of the ring

The electric potential at the axial distance is given as

$$V = \frac{1}{4\pi\epsilon_0} \frac{Q}{\sqrt{z^2 + a^2}}$$

The potential energy,  $U$  is given as

$$U = \frac{1}{4\pi\epsilon_0} \frac{Qq}{\sqrt{1 + \left(\frac{z}{a}\right)^2}}$$

When  $z = \text{infinity}$ ,  $U = 0$ .

When  $z = 0$ ,  $U$  is given as

$$U = -\frac{1}{4\pi\epsilon_0} \frac{Qq}{a}$$

2.23. Calculate potential on the axis of a ring due to charge  $Q$  uniformly distributed along the ring of radius  $R$ .

Answer:

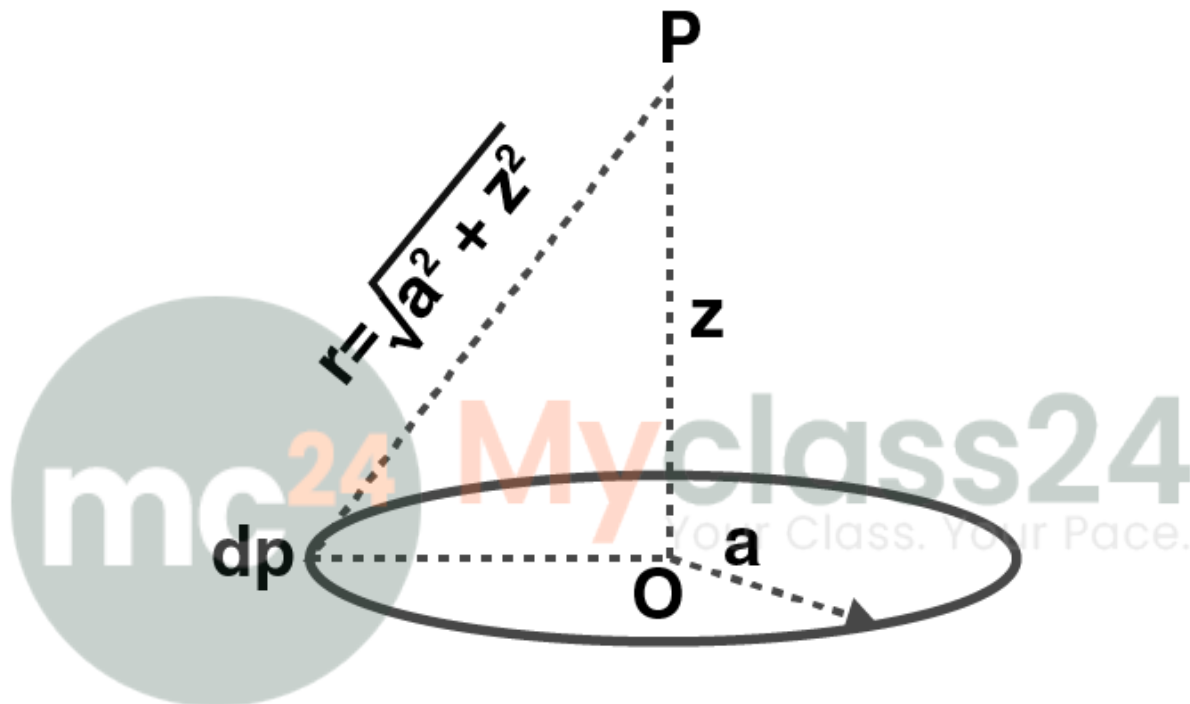

Point P is considered to be at a distance  $z$  from the centre of the ring. The charge  $dq$  is at a distance  $r$  from the point P.

$V$  is written as

$$V = \frac{1}{4\pi\epsilon_0} \int \frac{dq}{r} = \frac{1}{4\pi\epsilon_0} \int \frac{dq}{\sqrt{z^2 + a^2}}$$

Therefore, the net potential is given as

$$V = \frac{1}{4\pi\epsilon_0} \frac{Q}{\sqrt{z^2 + a^2}}$$

**Long Answers**

2.24. Find the equation of the equipotential for an infinite cylinder of radius  $r_0$ , carrying charge of linear density  $\lambda$ .

Answer:

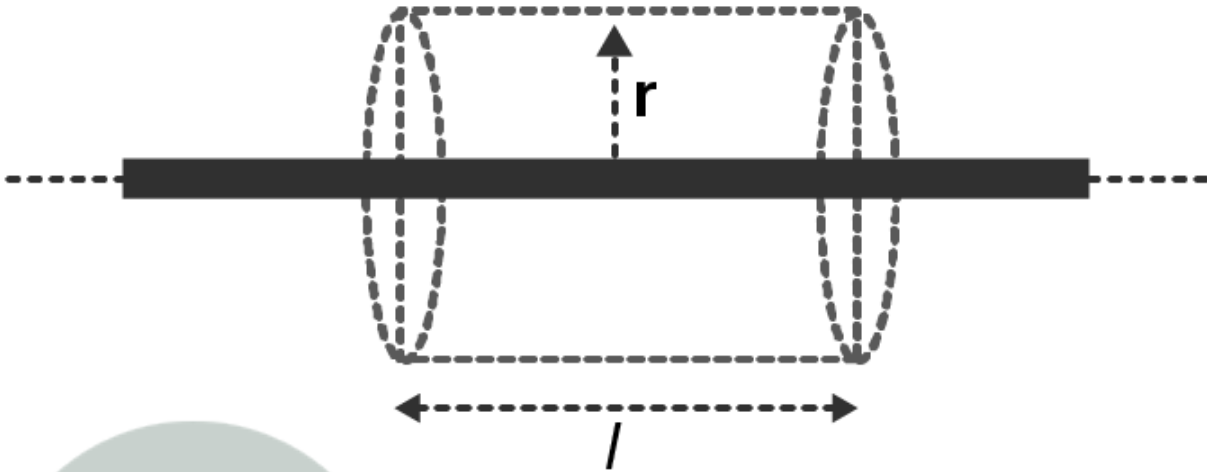

The equation of the equipotential for an infinite cylinder of radius  $r_0$  with linear charge density  $\lambda$  is given as:  
 $V(r) = \frac{\lambda}{2\pi\epsilon_0} \ln\left(\frac{r}{r_0}\right) + V(r_0)$

2.25. Two point charges of magnitude  $+q$  and  $-q$  are placed at  $(-d/2, 0, 0)$  and  $(d/2, 0, 0)$  respectively. Find the equation of the equipotential surface where the potential is zero.

Answer:

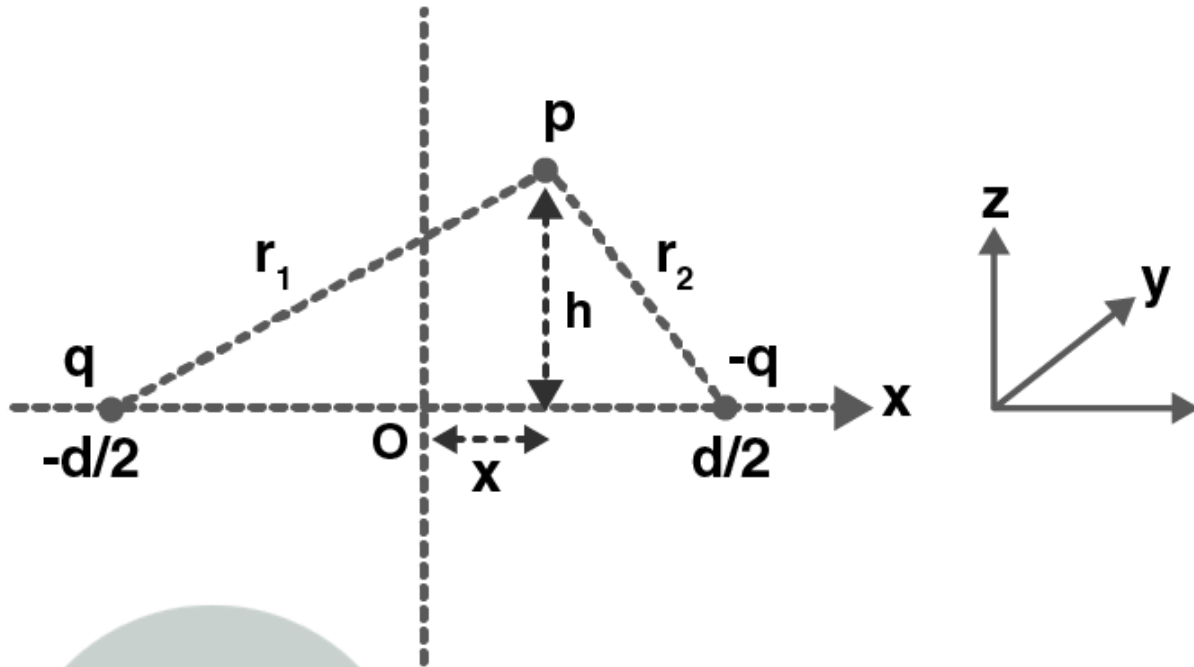

The potential at point P due to charges is given as

$$V_p = \frac{1}{4\pi\epsilon_0} \frac{q}{r_1} + \frac{1}{4\pi\epsilon_0} \frac{(-q)}{r_2}$$

The net electric potential at this point is zero,

Therefore,  $r_1 = r_2$

We know that

$$r_1 = \sqrt{(x + d/2)^2 + h^2}$$

$$r_2 = \sqrt{(x - d/2)^2 + h^2}$$

Solving the two equations, we get the required equation in plane  $x = 0$  that is y-z plane.

**2.26. A parallel plate capacitor is filled by a dielectric whose relative permittivity varies with the applied voltage (U) as  $\epsilon = \alpha U$  where  $\alpha = 2V^{-1}$ . A similar capacitor with no dielectric is charged to  $U_0 = 78 V$ . It is then connected to the uncharged capacitor with the dielectric. Find the final voltage on the capacitors.**

**Answer:**

Since the capacitors are connected in parallel, the potential difference across the capacitors is same. The final voltage is assumed to be U. C is the capacitance of the capacitor without dielectric, then the charge is given as  $Q_1 = CU$

The initial charge is given as

$$Q_0 = CU_0$$

The conservation of charges is

$$Q_0 = Q_1 + Q_2$$

$$CU_0 = CU + \alpha CU_2$$

## Class 12 Physics Chapter 2- Electrostatic Potential and Capacitance

$$\alpha U_2 + U - U_0 = 0$$

Solving the equation, we get  $U = 6V$

**2.27. A capacitor is made of two circular plates of radius  $R$  each, separated by a distance  $d \ll R$ . The capacitor is connected to a constant voltage. A thin conducting disc of radius  $r \ll R$  and thickness  $t \ll r$  is placed at a centre of the bottom plate. Find the minimum voltage required to lift the disc if the mass of the disc is  $m$ .**

**Answer:**

When the conducting disc is placed at the centre of the bottom plate, the potential of the disc is equal to the potential of the plate. The electric field on the disc is given as

$$E = V/d$$

The charge  $q'$  is transferred to the disc which is given as

$$q' = -\epsilon_0 V/d \pi r^2$$

The force acting on the disc is

$$F = \epsilon_0 V^2/d^2 \pi r^2$$

Therefore,  $V = \text{square root of } mdg / \pi \epsilon_0 r^2$

**2.28. a) In a quark model of elementary particles, a neutron is made of one up quarks and two down quarks. Assume that they have a triangle configuration with side length of the order of  $10^{-15}$  m. Calculate electrostatic potential energy of neutron and compare it with its mass 939 MeV.**

**b) Repeat above exercise for a proton which is made of two up and one down quark.**

**Answer:**

There are three charges in the system. The potential energy of the system is equal to the sum of PE of each pair.

$$U = 1/4 \pi \epsilon_0 \{q_d q_d / r - q_u q_d / r - q_u q_d / r\}$$

Substituting the values we get,

$$U = 5.11 \cdot 10^{-4}$$

**2.29. Two metal spheres, one of radius  $R$  and the other of radius  $2R$ , both have same surface charge density  $\sigma$ . They are brought in contact and separated. What will be new surface charge densities on them?**

**Answer:**

Following are the charges on the metal sphere before contact

$$Q_1 = \sigma \cdot 4\pi R^2$$

$$Q_2 = \sigma \cdot 4\pi (2R)^2 = 4Q_1$$

$Q_1'$  and  $Q_2'$  are the charges on the metal sphere after contact

$$Q_1' + Q_2' = Q_1 + Q_2 = 5Q_1$$

When the metal spheres are in contact, following is the potentials acquired by them

$$Q_1' = Q_2' / 2$$

Solving the equations we

$$\sigma_1 = 5 \sigma / 3$$

$$\sigma_2 = 5 \sigma / 6$$

**2.30. In the circuit shown in the figure, initially  $K_1$  is closed and  $K_2$  is open. What are the charges on each capacitors. Then  $K_1$  was opened and  $K_2$  was closed. What will be the charge on each capacitor now?**

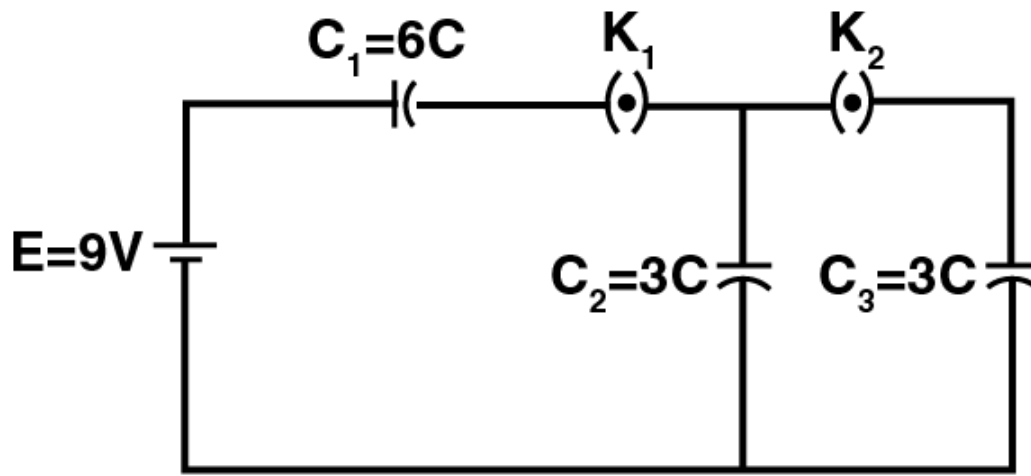

Answer:

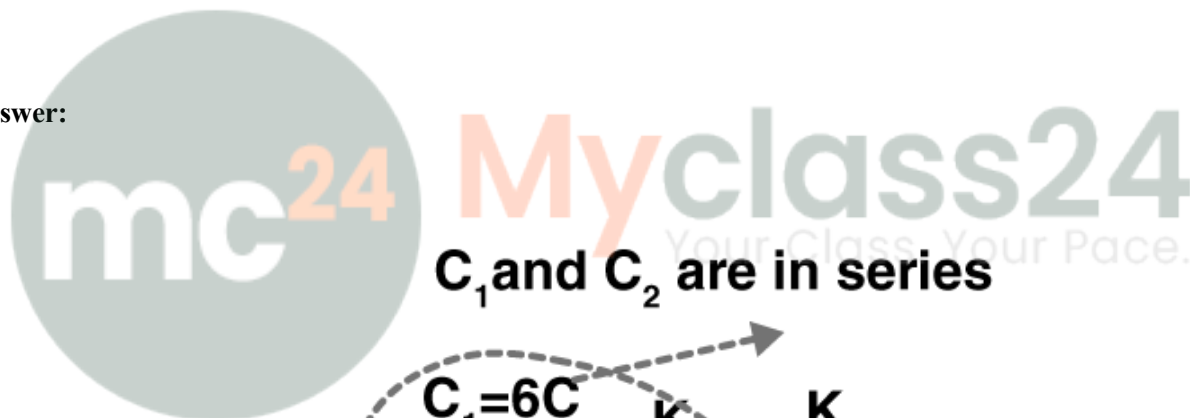

$C_1$  and  $C_2$  are in series

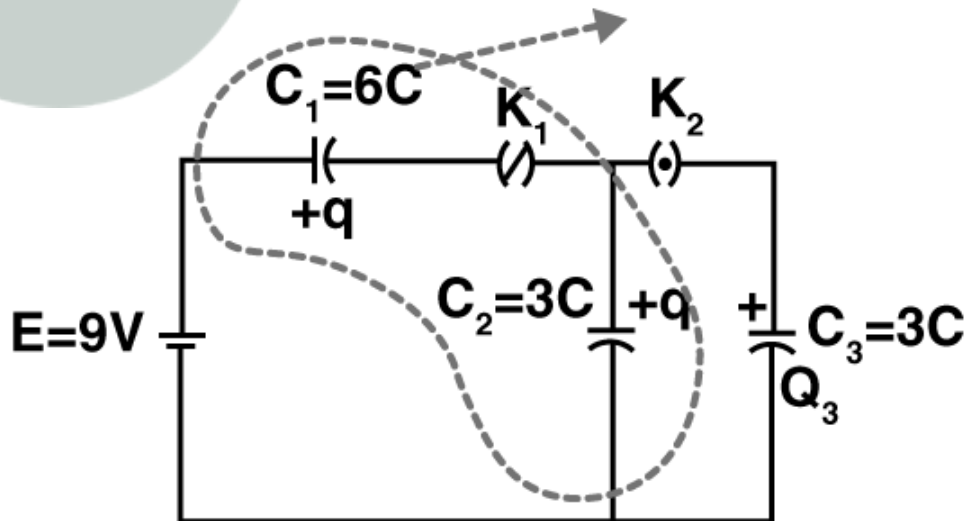

When  $K_1$  is closed and  $K_2$  is open, the capacitors  $C_1$  and  $C_2$  are connected in series with the battery  
Therefore, the charge in capacitors  $C_1$  and  $C_2$  are

$$Q_1 = Q_2 = q = (C_1 C_2 / C_1 + C_2) E = 18 \mu\text{C}$$

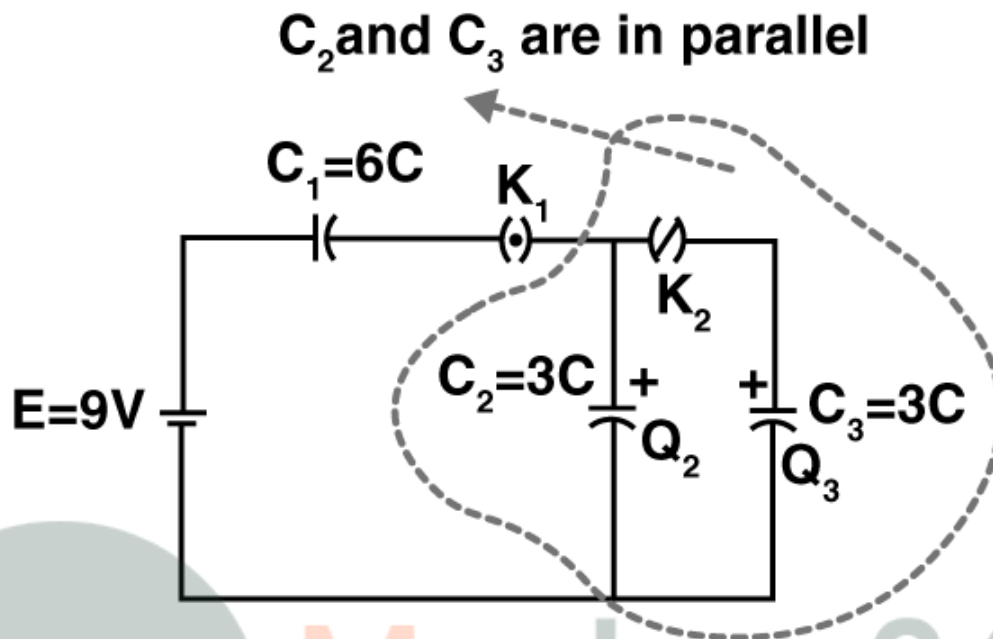

When the capacitors  $C_2$  and  $C_3$  are placed in parallel,

$$C_2 V' + C_3 V' = Q_2$$

$$V' = Q_2 / C_2 + C_3 = 3V$$

Therefore,

$$Q_2' = 3C V' = 9 \mu\text{C}$$

$$Q_3' = 3C V' = 9 \mu\text{C}$$

$$Q_1' = 18 \mu\text{C}$$

**2.31. Calculate potential on the axis of a disc of radius R due to a charge Q uniformly distributed on its surface.**

**Answer:**

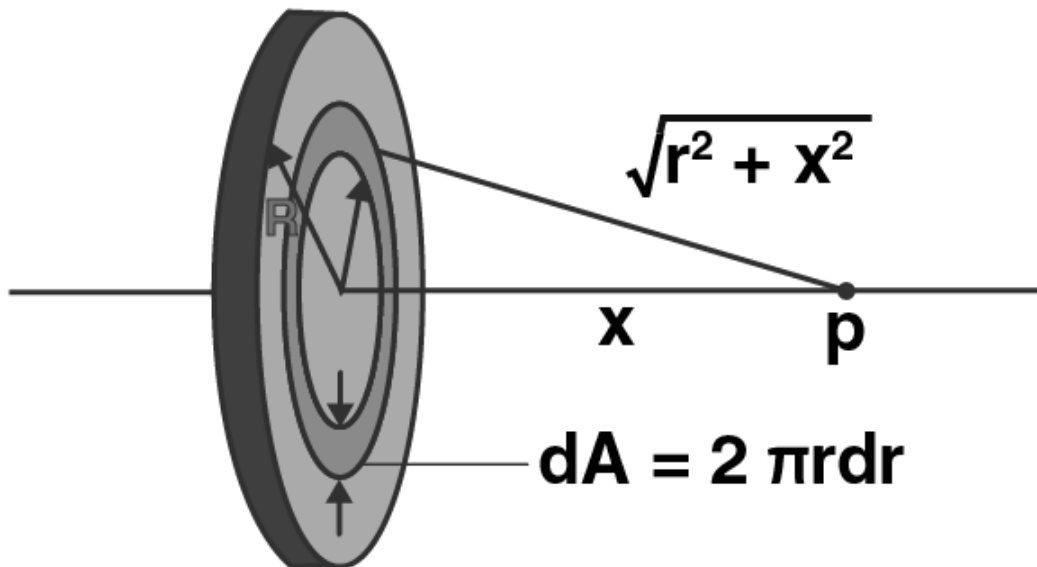

In the above figure we can see that the disc is divided into a number of charged rings. Let P be the point on the axis of the disc at a distance  $x$  from the centre of the disc.

The radius of the ring is  $r$  and width is  $dr$ .  $dq$  is the charge on the ring which is given as

$$dq = \sigma dA = \sigma 2\pi r dr$$

The potential is given as

$$dV = \frac{1}{4\pi\epsilon_0} \frac{dq}{\sqrt{r^2 + x^2}} = \frac{1}{4\pi\epsilon_0} \frac{(\sigma 2\pi r dr)}{\sqrt{r^2 + x^2}}$$

The total potential at P is given as

$$Q/2\pi\epsilon_0 R^2 (\sqrt{R^2 + x^2} - x)$$

**2.32. Two charges  $q_1$  and  $q_2$  are placed at  $(0, 0, d)$  and  $(0, 0, -d)$  respectively. Find locus of points where the potential is zero.**

**Answer:**

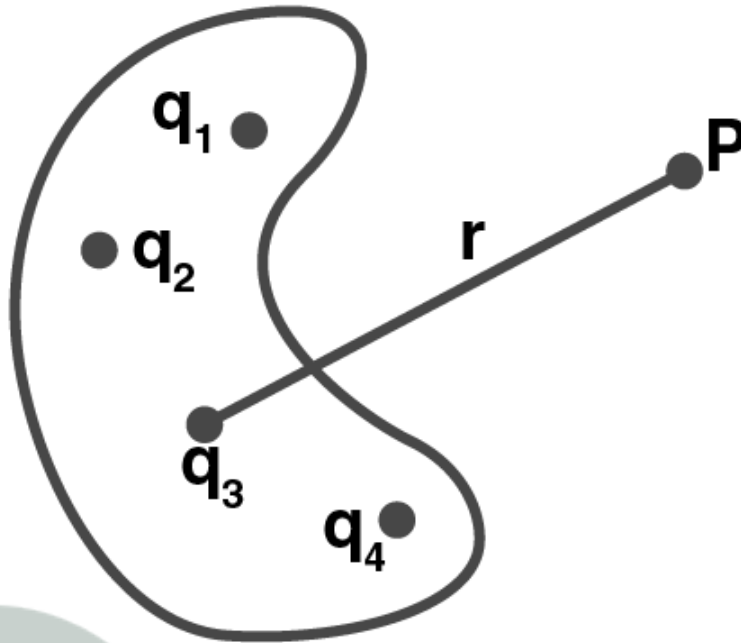

We know that the potential at point P is  $V = \sum V_i$

Where  $V_i = q_i/4\pi\epsilon_0 r_i$ ,  $r_i$  is the magnitude of the position vector P

$$V = 1/4 \pi\epsilon_0 \sum q_i/r_{pi}$$

When (x,y,z) plane is considered, the two charges lie on the z-axis and is separated by 2d. The potential is given as

$$\frac{q_1}{\sqrt{x^2 + y^2 + (z - d)^2}} + \frac{q_2}{\sqrt{x^2 + y^2 + (z + d)^2}} = 0$$

Squaring the equation, we get

$$x^2 + y^2 + z^2 + [(q_1/q_2)^2 + 1/(q_1/q_2)^2 - 1] (2zd) + d^2 = 0$$

Therefore, the equation of sphere is

$$x^2 + y^2 + z^2 + 2ux + 2uy + 2wz + g = 0$$

Centre of the sphere is

$$(0, 0, -d \left[ \frac{q_1^2 + q_2^2}{q_1^2 - q_2^2} \right])$$

And radius is

$$r = \frac{2q_1q_2d}{q_1^2 - q_2^2}$$

2.33. Two charges  $-q$  each are separated by distance  $2d$ . A third charge  $+q$  is kept at mid point O. Find potential energy of  $+q$  as a function of small distance  $x$  from O due to  $-q$  charges. Sketch PE versus  $x$  and convince yourself that the charge at O is in an unstable equilibrium.

Answer:

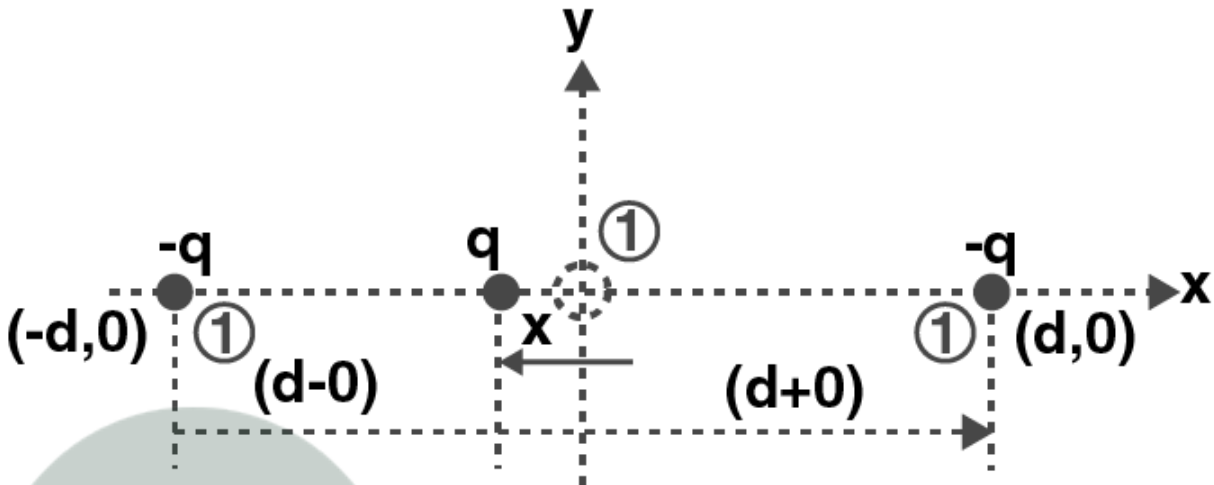

In the above figure,  $+q$  is the charge that got displaced from O towards  $(-d, 0)$ . This is written as

$$U = q(V_1 + V_2) = q \frac{1}{4\pi\epsilon_0} \frac{-q}{(d-x)} + \frac{-q}{d+x}$$

$$U = \frac{1}{2\pi\epsilon_0} \frac{-q^2 d}{d^2 - x^2}$$

At  $x = 0$

$$U = \frac{1}{2\pi\epsilon_0} \frac{q^2}{d}$$

Differentiating the equation with respect to  $x$ , we get

When  $x < 0$ ,  $dU/dx > 0$

And when  $x > 0$ ,  $dU/dx < 0$

Using this we can define, force on particle to be  $F = -dU/dx$

$F = -dU/dx = 0$

When

$d^2U/dx^2 = \text{positive}$ , equilibrium is stable

$d^2U/dx^2 = \text{negative}$ , equilibrium is unstable

$d^2U/dx^2 = 0$ , equilibrium is neutral

Therefore, when  $x = 0$ ,  $d^2U/dx^2 = (-2dq^2/4\pi\epsilon_0)(1/d^6)(2d^2) < 0$

Which shows that the system is unstable equilibrium.



**Myclass24**  
Your Class. Your Pace.