

## Chapter 15. Construction of Polygons (Using ruler and compass only)

### Solution 1:

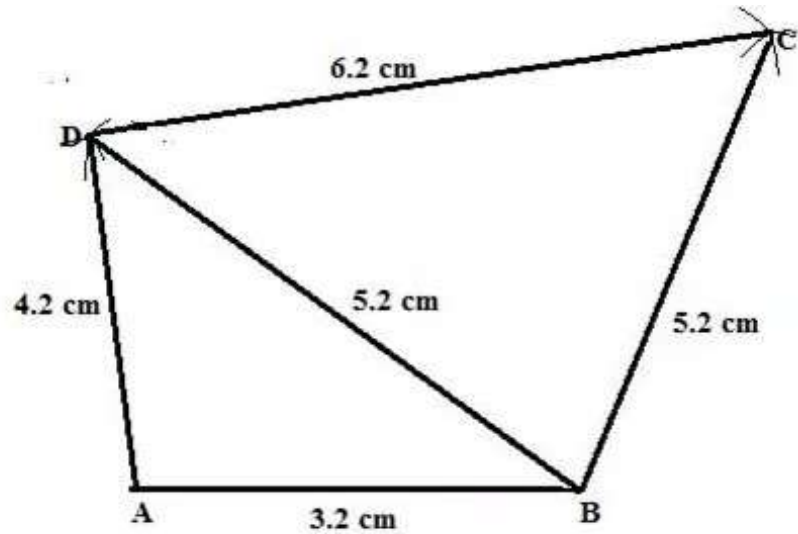

Steps:

1. Draw  $AB = 3.2\text{ cm}$ .
  2. With A as a centre draw an arc at D and with B as a centre and radius  $5.2\text{ cm}$  draw an arc at D.
  3. Join AD and DB.
  4. With D and B as a centre taking radius  $6.2\text{ cm}$  and  $5.2\text{ cm}$  draw arc at C. Now join BC and DC.
- ABCD is the required quadrilateral.

### Solution 2:

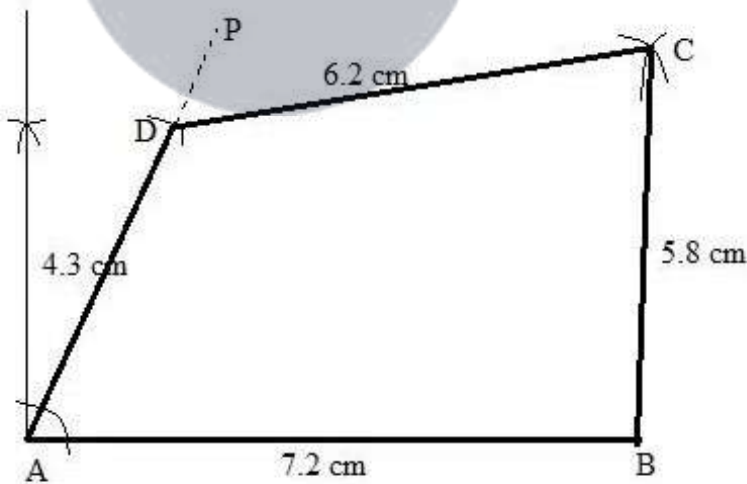

Steps:

1. Draw  $AB = 7.2\text{ cm}$ .
  2. Through A draw AP such that  $\angle A = 75^\circ$ .
  3. From AP cut  $AD = 4.3\text{ cm}$ .
  4. With D and B as centre and radii  $6.2\text{ cm}$  and  $5.8\text{ cm}$  respectively, draw arcs cutting each other at C.
  5. Join DC and BC.
- ABCD is the required quadrilateral.

### Solution 3:

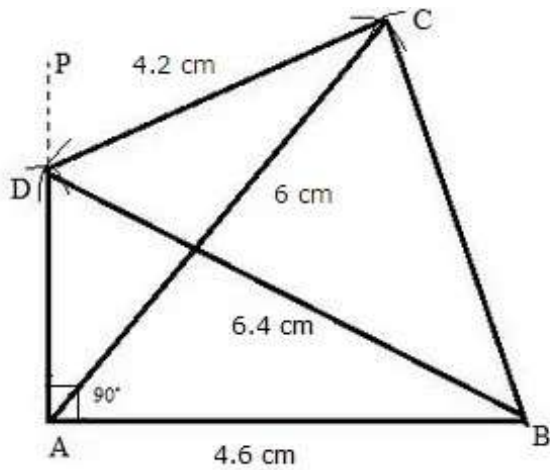

Steps:

1. Draw  $AB = 4.6$  cm
2. Through A, draw AP such that Angle A =  $90^\circ$ .
3. With B as a centre and radii 6.4 cm draw an arc at D on AP.
4. With D and A as a centre and radii 4.2 cm and 6 cm draw arc cutting each other at C.
5. Now join BD, AC and CB.

ABCD is the required quadrilateral.

### Solution 4:

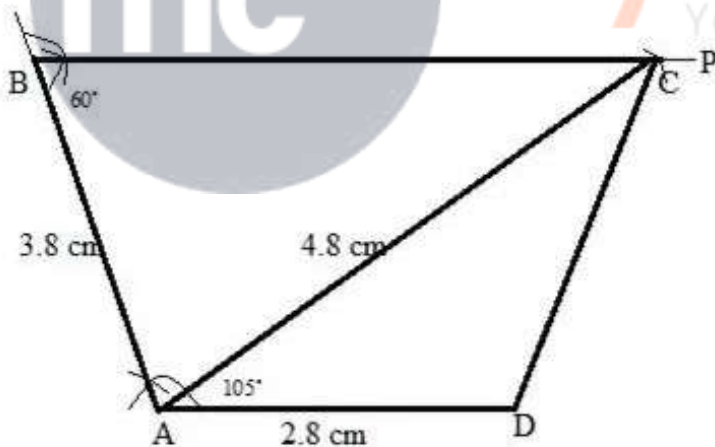

Steps:

1. Draw  $AD = 2.8$  cm.
2. Draw  $AB = 3.8$  cm and  $\angle A = 105^\circ$ .
3. draw BP such that  $\angle B = 60^\circ$ .
4. With A as a centre and radii 4.8 cm draw an arc cutting BP at C.
5. Join AC, AD.

ABCD is the required quadrilateral.

### Solution 5:

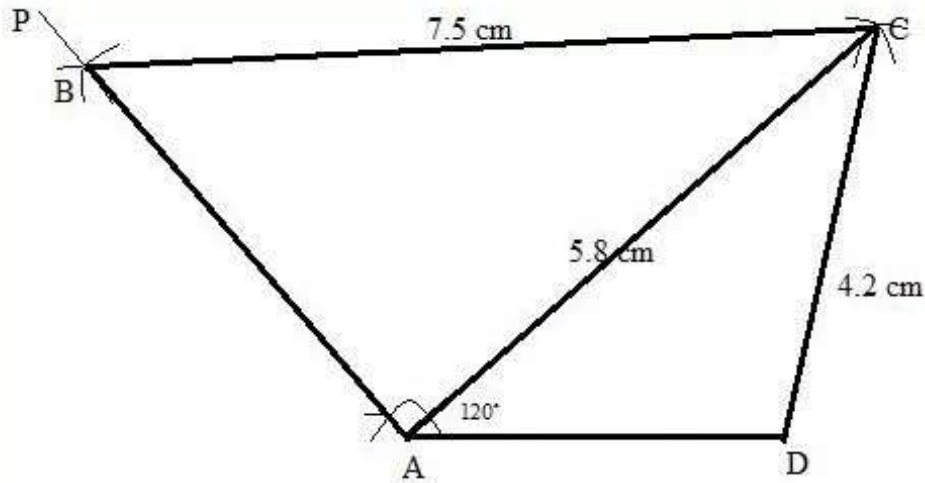

Steps:

1. Draw  $AD = 3.6\text{ cm}$ .
2. draw AP such that  $\angle A = 120^\circ$ .
3. With A and D as a centre and radii 5.8 cm and 4.2 cm draw arcs cutting each other at C.
4. Now join AC and CD.
5. Now with C as centre and radii 7.5 cm draw an arc at B on AP.
6. Now join CB.

ABCD is the required quadrilateral.

**Myclass24**  
Your Class. Your Pace.

### Solution 6:

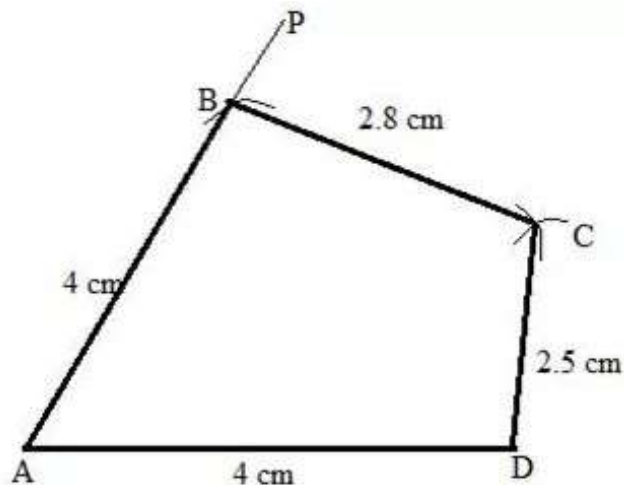

Steps:

1. Draw  $AD = 4\text{ cm}$ .
2. Draw AP such that  $\angle A = 45^\circ$ .
3. With A as a centre with radii 4 cm draw an arc at B on AP.
4. Now taking B and D as a centre and radii 2.8 cm and 2.8 cm draw arcs cutting each other at C.
5. Now join BC and CD.

ABCD is the required quadrilateral.

**Solution 7:**

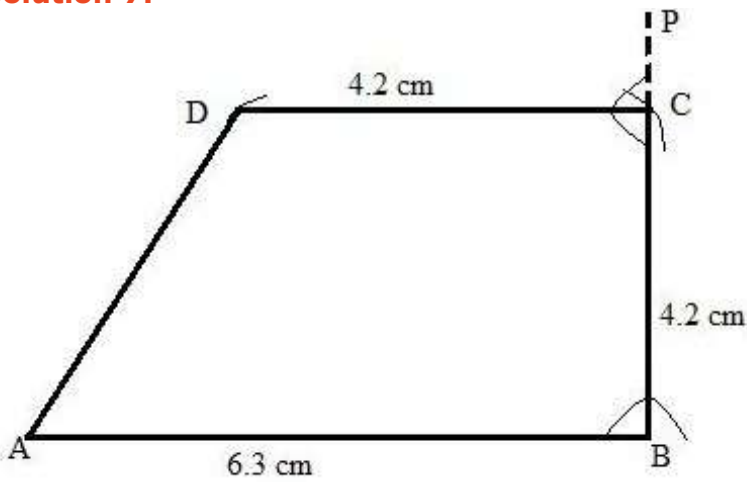

Steps:

1. draw  $AB = 6.3\text{ cm}$ .
2. Draw BP such that  $\angle ABP = 90^\circ$ .
3. With B as a centre and radii 4.2 cm draw an arc AP at C.
4. With C as a centre draw a line CD with radii 4.2 cm draw a line such that  $\angle BCD = 90^\circ$ .
5. Now join AD

ABCD is the required quadrilateral.

**Solution 8:**

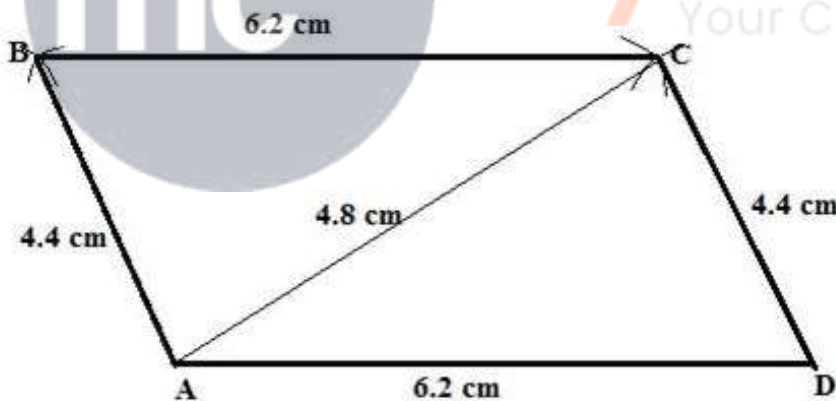

Steps:

1. Draw  $AD = 6.2\text{ cm}$ .
2. Draw triangle ACD.
3. Then draw triangle ABC.

ABCD is the required parallelogram.

### Solution 9:

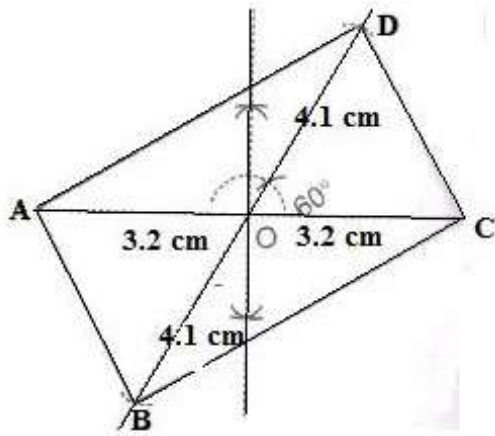

Steps:

1. Draw  $AC = 6.4\text{ cm}$ .

2. Draw line BOD such that  $\angle DOC = 60^\circ$  and  $OB = OD = \frac{1}{2}BD = \frac{1}{2} \times 8.2 = 4.1\text{ cm}$ .

3. Join AB, BC, CD and DA.

ABCD is the required parallelogram.

### Solution 10:

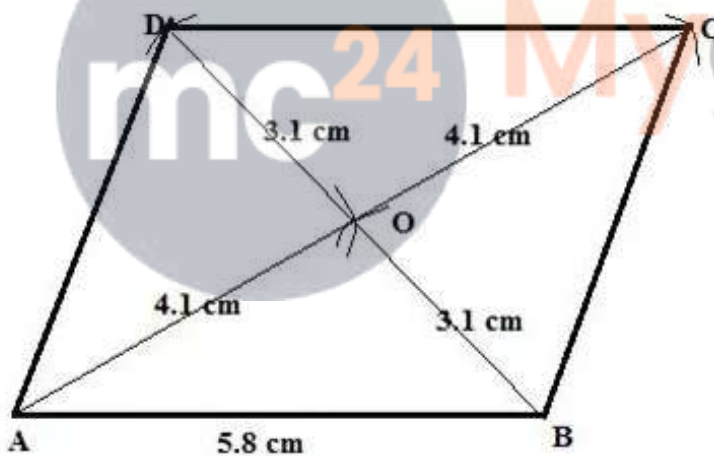

Steps:

1. Since diagonal of a parallelogram bisect each other, construct OAB such that ;

$$OA = \frac{1}{2}AC = \frac{1}{2} \times 8.2\text{ cm} = 4.1\text{ cm}$$

$$OB = \frac{1}{2}BD = \frac{1}{2} \times 6.2\text{ cm} = 3.1\text{ cm}$$

And  $AB = 5.8\text{ cm}$ .

2. Produce AO up to C, such that  $OC = OA = 4.1\text{ cm}$  and BO upto D, such that  $DO = OB = 3.1\text{ cm}$ .

3. Join AD, DC and CB.

ABCD is the required parallelogram.

**Solution 11:**

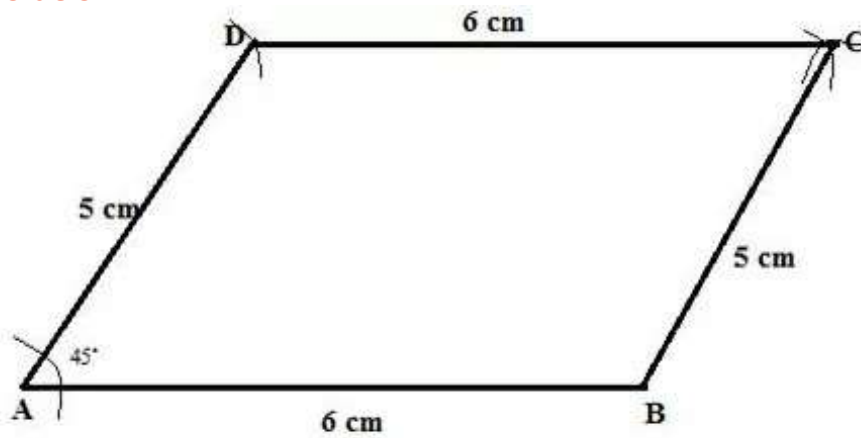

Steps:

1. Draw  $AB = 6\text{ cm}$ .
2. Draw AD with radii 5 cm with an angle of  $45^\circ$ .
3. With D and B as a centre and radii 6 cm and 5 cm draw arcs cutting each other at C.
4. Now join DC and BC.

ABCD is the required parallelogram.

**Solution 12:**

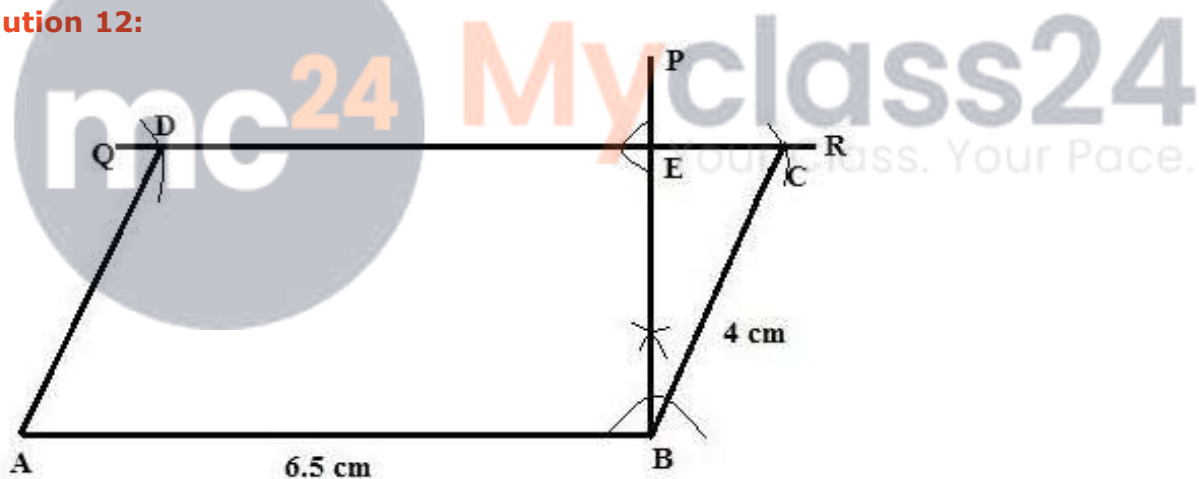

Steps:

1. Draw  $AB = 6.5\text{ cm}$ .
2. At B, draw  $BP \perp AB$ .
3. From BP cut  $BE = 3.1\text{ cm}$ .
4. Through E draw perpendicular to BP to get QR parallel to AB.
5. With B as a centre and radius =  $BC = 4\text{ cm}$ , draw an arc which cuts QR at C.
6. With A as a centre and radius =  $AD = 4\text{ cm}$ , draw an arc which cuts QR at D.

ABCD is the required parallelogram.

**Solution 13:**

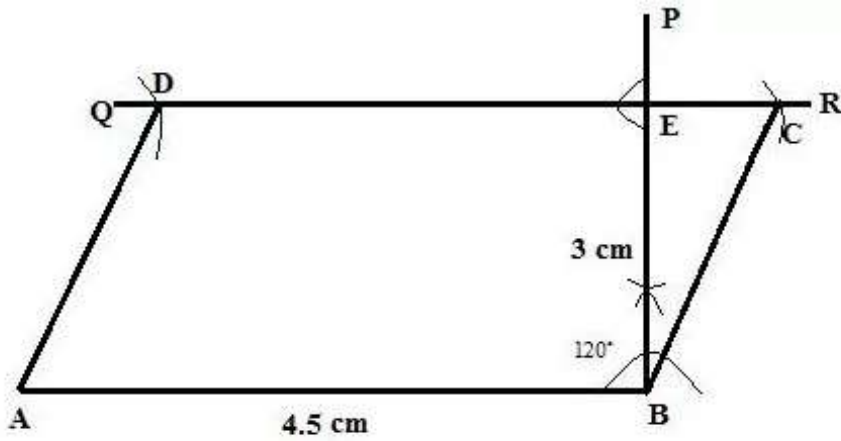

Steps:

1. Draw  $AB = 4.5\text{cm}$ .
2. At B, draw  $BP \perp AB$ .
3. From BP cut  $BE = 3\text{cm}$ .
4. Through E draw perpendicular to BP to get QR parallel to AB.
5. With B as a centre draw an arc which cuts QR at C.
6. With A as a centre draw an arc which cuts QR at D.
7. Now join Ad and BC.

ABCD is the required parallelogram.

**mc24 Myclass24**  
Your Class. Your Pace.

**Solution 14:**

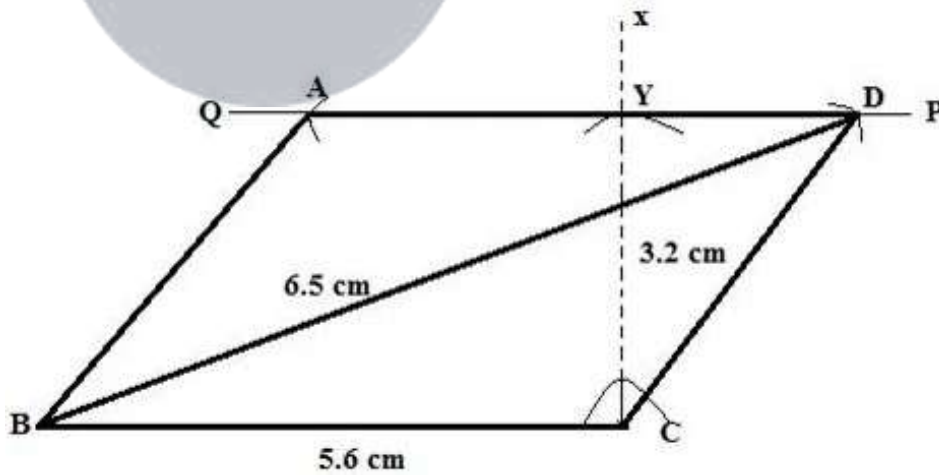

Steps:

1. Draw  $BC = 5.6\text{ cm}$ .
  2. At C, draw CX perpendicular to BC.
  3. with C as a centre and taking radius 3.2 cm draw an arc to cut CX at Y.
  4. Through Y draw a straight line PQ parallel to BC.
  5. With B as a centre and radius 6.5 cm draw an arc to meet PQ at D.
  6. With D as a centre and radius equal to 5.6 cm , draw an arc to meet PQ at A.
  7. Join BA, BD and CD.
- ABCD is the required parallelogram.

### Solution 15:

Since each angle of a rectangle is  $90^\circ$  and opposite sides are equal. Therefore,

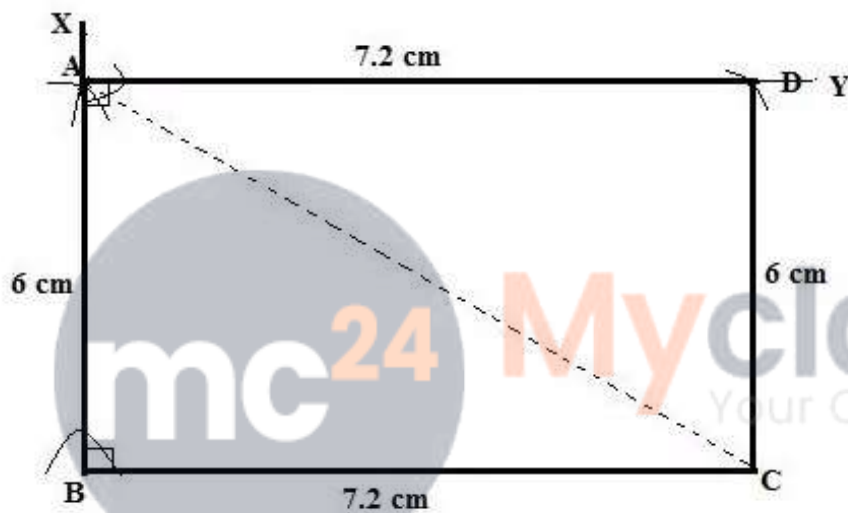

Steps:

1. Draw  $BC = 7.2\text{ cm}$ .
2. with B as a centre draw a line BX taking as a  $90^\circ$ .
3. Now taking radius 6 cm draw an arc at A.
4. From point A draw a line AY parallel to BC.
5. With A as a centre taking radius 7.2 cm draw an arc at D.
6. Now join CD.

ABCD is the required rectangle.

### Solution 16:

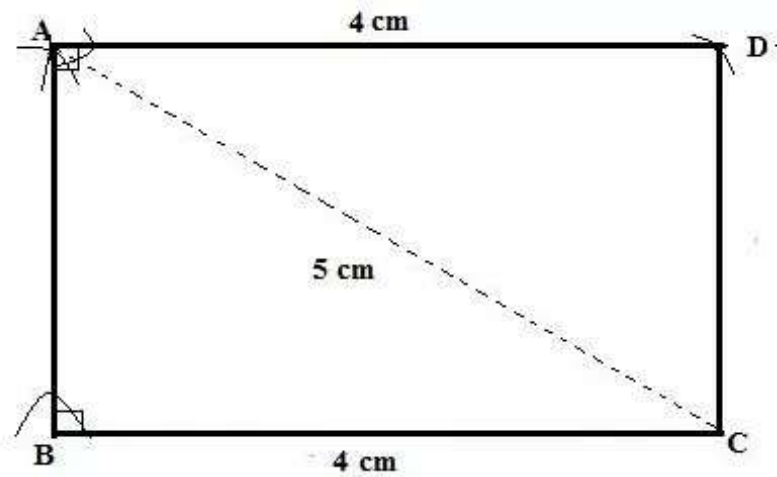

Steps:

1. Draw  $BC = 4\text{ cm}$ .
  2. With C as a centre and radius 5 cm draw an arc at A.
  3. Now join AB and AC.
  4. With A as a centre draw an arc at D.
  5. Now join AD and CD.
- ABCD is the required rectangle.

### Solution 17:

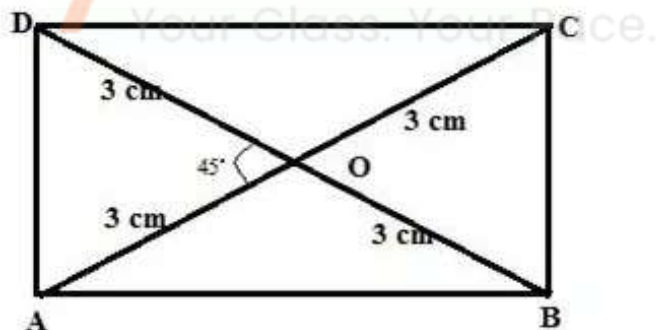

Steps:

1. Draw  $AC = 6\text{ cm}$ .
2. Draw right triangle ACB.
3. Draw right triangle ADB.
4. Join DC.

ABCD is the required rectangle.

**Solution 18:**

Given that the base =  $4.8\text{ cm}^2$  and Area =  $24\text{ cm}^2$

We know that area of rectangle =  $\text{base} \times \text{Height}$ .

Therefore,

$$24 = 4.8 \times \text{height}$$

$$\text{Height} = 5$$

With  $\text{base} = 4.8\text{ cm}^2$  and height  $5\text{ cm}^2$ , the rectangle is shown below:

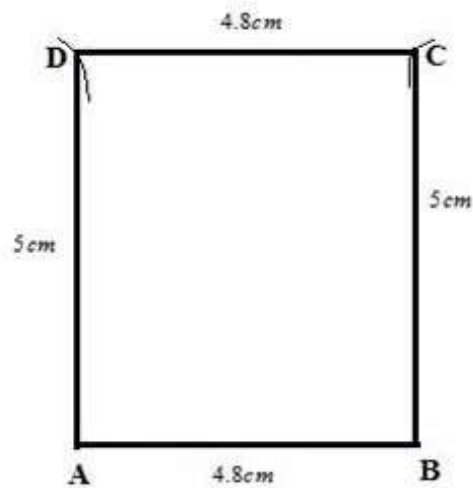

Steps:

1. Draw base  $AB = 4.8\text{ cm}^2$ .
2. With A and B as a centre draw an arcs taking radius  $5\text{ cm}^2$  at D and C.
3. Now join AD, BC and DC.

ABCD is the required rectangle.

mc24

Myclass24  
Your Class. Your Pace.

**Solution 19:**

Given that the height = 4.5 cm and Area =  $36\text{cm}^2$

We know that area of rectangle =  $\text{base} \times \text{Height}$ .

Therefore,

$$36 = \text{base} \times 4.5$$

$$\text{Base} = 8 \text{ cm}$$

With height = 4.5 and base 8cm, the rectangle is shown below:

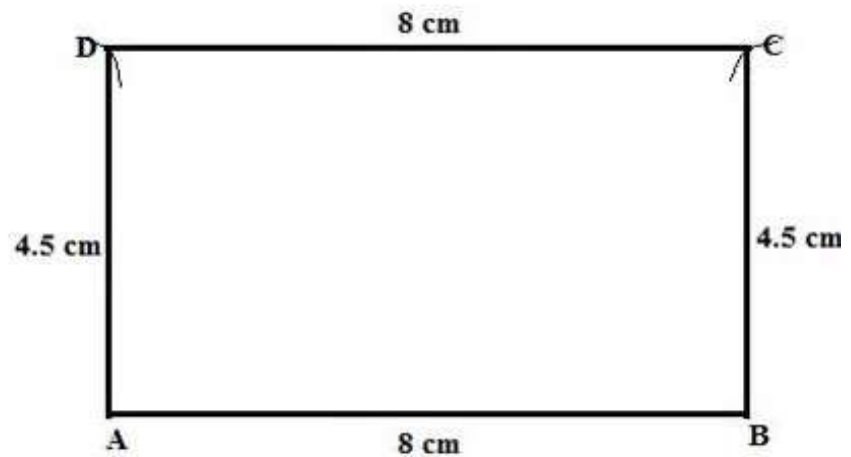

Steps:

1. Draw base  $AB = 8\text{cm}$ .
2. With A and B as a centre draw an arcs taking radius 4.5 cm at D and C.
3. Now join AD, BC and DC.

ABCD is the required rectangle.

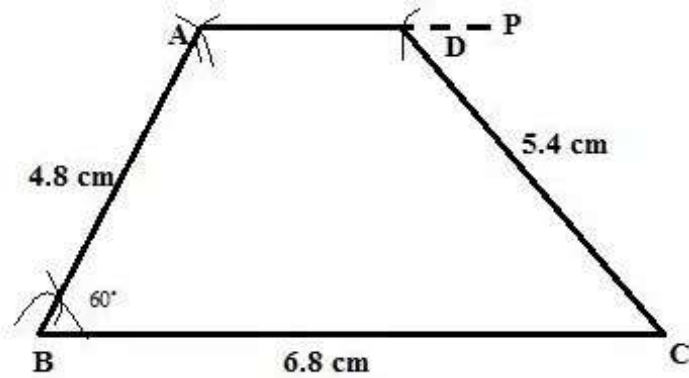
**Solution 20:**

Steps:

1. Draw  $BC = 6.8\text{ cm}$ .
2. With B as a centre and radii 4.8 cm draw an arc at A such that  $\angle B = 60^\circ$ .
3. From point A draw a line AP such that  $AP \parallel BC$ .
4. With C as a centre and radii 5.4 cm draw an arc at D on the line AP.
5. Now join AB, CD.

ABCD is the required trapezium.

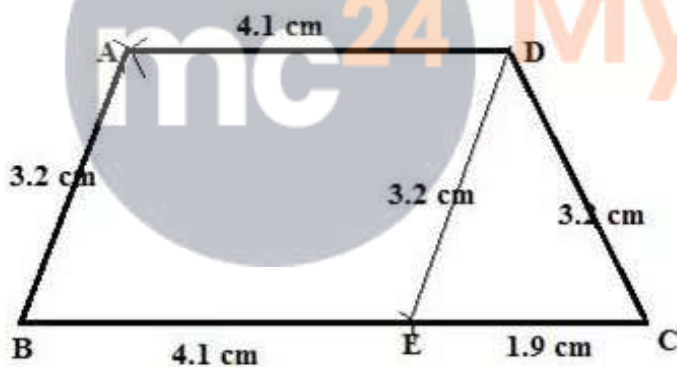
**Solution 21:**

Steps:

1. Draw  $BC = 6\text{ cm}$ .
2. From BC cut  $BE = AD = 4.1\text{ cm}$ .
3. draw triangle DEC such that  $DE = AB = 3.2\text{ cm}$  and  $CD = 3.2\text{ cm}$ .
4. Taking B and D as a centre and radii 3.2 cm and 4.1 cm respectively, draw arcs cutting each other at A.
5. Join AB and AD.

ABCD is the required trapezium.

### Solution 22:

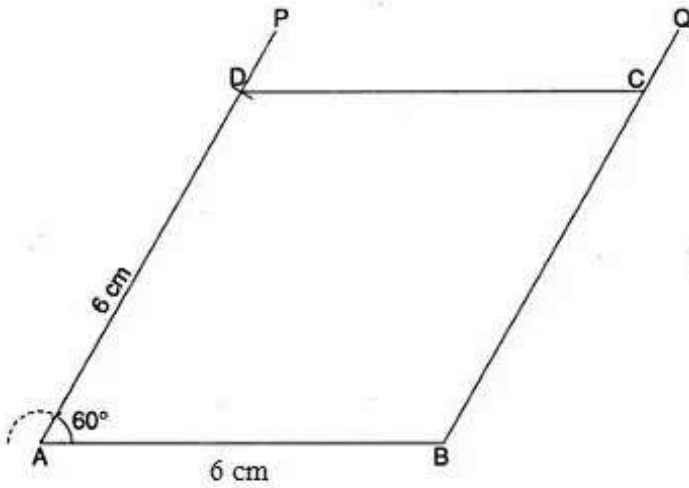

Steps:

1. Draw a line  $AB = 6\text{ cm}$ .
2. At A, we construct  $\angle BAP = 60^\circ$ .
3. From AP, we cut at D taking  $AD = 6\text{ cm}$ .
4. Through B, we draw  $BQ \parallel AD$ .
5. through D, we draw  $DC \parallel AB$  to cut BQ at C.

ABCD is the required rhombus.

### Solution 23:

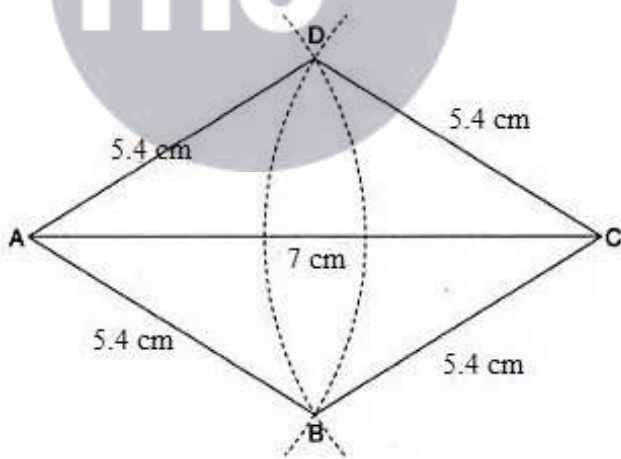

Steps:

1. We construct the segment  $AC = 7\text{ cm}$ .
2. With A as a centre and radius  $5.4\text{ cm}$ , we draw an arc extending on both sides of AC.
3. With C as centre and same radius as in step 2, we draw an arc extending on both sides of AC to cut the first arc at B and D.
4. Join AB, BC, CD and DA.

ABCD is the required rhombus.

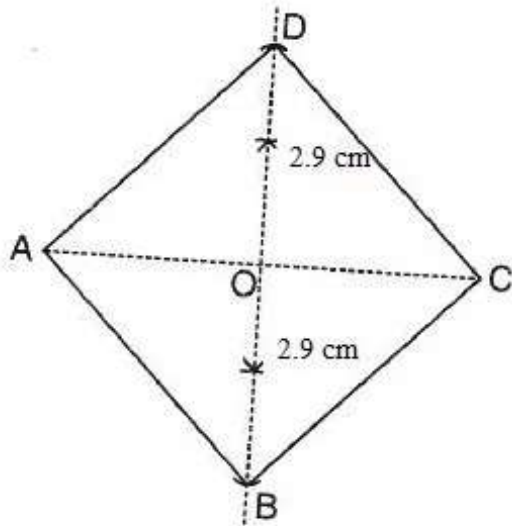
**Solution 24:**

Steps:

1. Draw  $AC = 6.3\text{cm}$ .
2. Draw perpendicular bisector to AC which cuts AC at O.
3. From this perpendicular cut OD and OB such that,

$$OD = OB = \frac{1}{2}BD = \frac{1}{2} \times 5.8 = 2.9\text{cm}.$$

4. Join AB, BC, CD and DA.

ABCD is the required rhombus.

**mc24 Myclass24**  
Your Class. Your Pace.

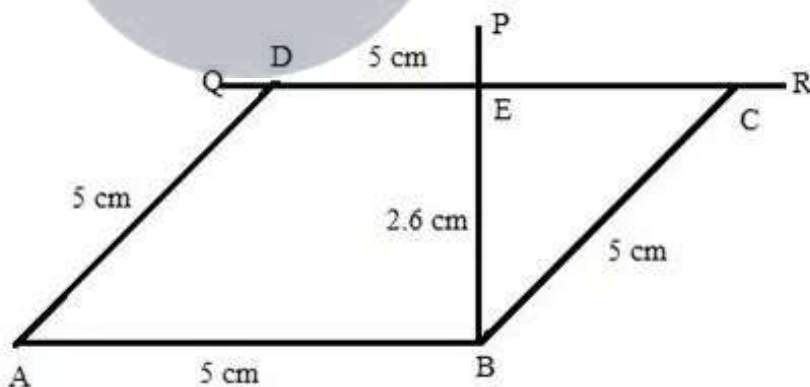
**Solution 25:**

Steps:

1. Draw  $AB = 5\text{cm}$ .
2. At B, draw  $BP \perp AB$ .
3. From BP, cut  $BE = 2.6\text{cm} = \text{height}$ .
4. Through E draw perpendicular to BP to get QR parallel to AB.
5. With A and B as a centre and radii 5 cm draw arcs cutting QR at D and C.

ABCD is the required rhombus.

### Solution 26:

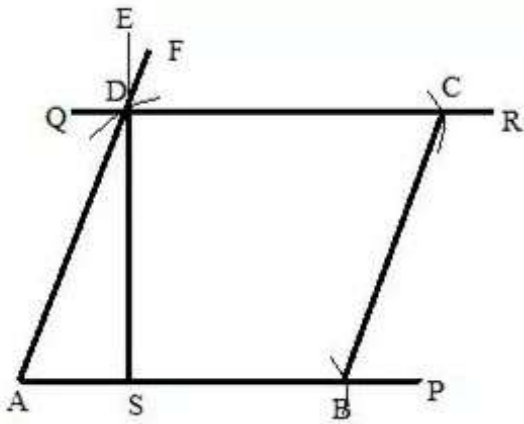

Steps:

1. Draw a line AP.
2. Now draw a line AF such that  $\angle A = 60^\circ$ .
3. At S draw a perpendicular SE of length 3 cm such that it cut at AF at D.
4. Through D draw a line QR parallel to AP.
5. Now taking the radius same as AD draw an arc at B on AP.
6. Now through and B taking radius same as AD and AB draw arcs cutting each other at C.
7. Now join BC.

ABCD is the required rhombus.

**mc24 Myclass24**  
Your Class. Your Pace.

### Solution 27:

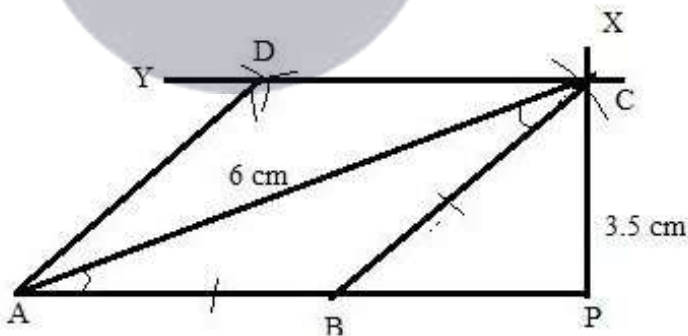

Steps:

1. draw a line AP.
2. now draw  $AC = 6\text{ cm}$  and  $CP = 3.5\text{ cm}$ .
3. Now draw a line BC such that  $AB = BC$ .
4. Now at C draw a line CY parallel to AP.
5. At point C and A, taking radius same as AB draw arcs cutting each other at D.
6. Now join AD.

ABCD is the required rhombus.

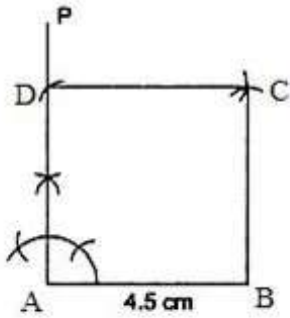
**Solution 28:**

Steps:

1. Draw a line segment  $AB = 4.5\text{cm}$ .
2. Draw  $AP \perp AB$ .
3. From AP cut off  $AD = 4.5\text{cm}$ .
4. With B as a centre and radius 4.5 cm draw an arc.
5. With D as centre and radius 4.5 cm draw another arc cutting the former arc at C.
6. Join BC and CD.

ABCD is the required square.

**Solution 29:**

We know that the diagonals of a square are equal and bisect each other at right angles.

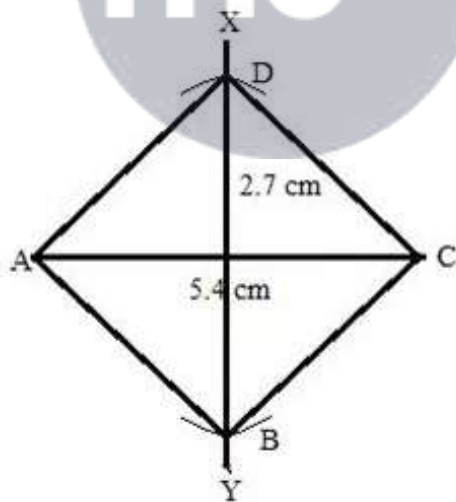

Steps:

1. draw  $AC = 5.4\text{cm}$ .
2. Draw the right bisector XY of AC, meeting AC at O.
3. From O, set off  $OB = \frac{1}{2}(5.4) = 2.7\text{cm}$  along OY and  $OD = 2.7\text{cm}$  along OX.
4. Join AB, BC, CD and DA.

ABCD is the required square.

### Solution 30:

The perimeter of a square

$$P = 4a$$

Where  $a$  is the length of each side.

We have Perimeter = 24 cm.

Therefore,

$$24 = 4a$$

$$a = 6$$

Therefore the sides of the squares are of length 6 cm.

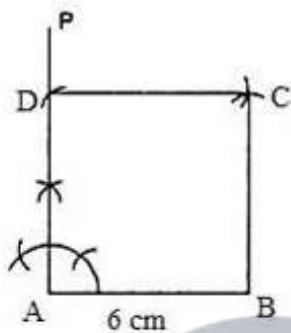

Steps:

1. Draw a line segment  $AB = 6\text{ cm}$ .
2. Draw  $AP \perp AB$ .
3. From AP cut off  $AD = 6\text{ cm}$ .
4. With B as a centre and radius 6 cm draw an arc.
5. With D as centre and radius 6 cm draw another arc cutting the former arc at C.
6. Join BC and CD.

ABCD is the required square.

### Solution 31:

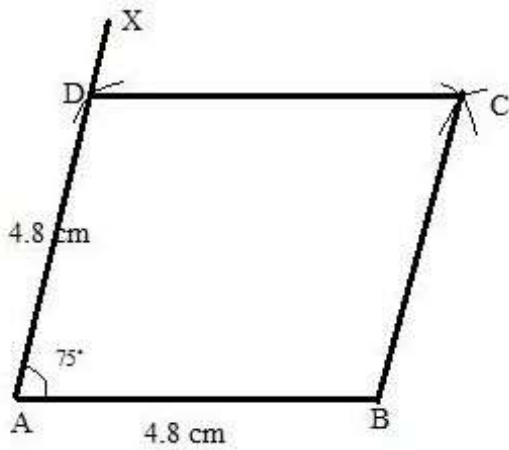

Steps:

1. draw a line  $AB = 4.8\text{cm}$ .
  2. At A Draw AX such that  $\angle BAX = 75^\circ$ .
  3. With A as a centre and measurement equal to AB cut off an arc at D on AX.
  4. Using same radius taking D and B as centers cut off arcs, which will intersect at C.
  5. Join CD and CB,
- ABCD is the required rhombus.

### Solution 32:

To draw the rectangle follows the steps:

- (1) First draw a line AC of measure 6cm.
- (2) Then draw the perpendicular bisector of AC through O.
- (3) At O draw an angle of measure  $45^\circ$ . Then produce OD of measure 3cm and OB of measure 3cm each.
- (4) Now join AD, AB, BC and CD to form the rectangle.

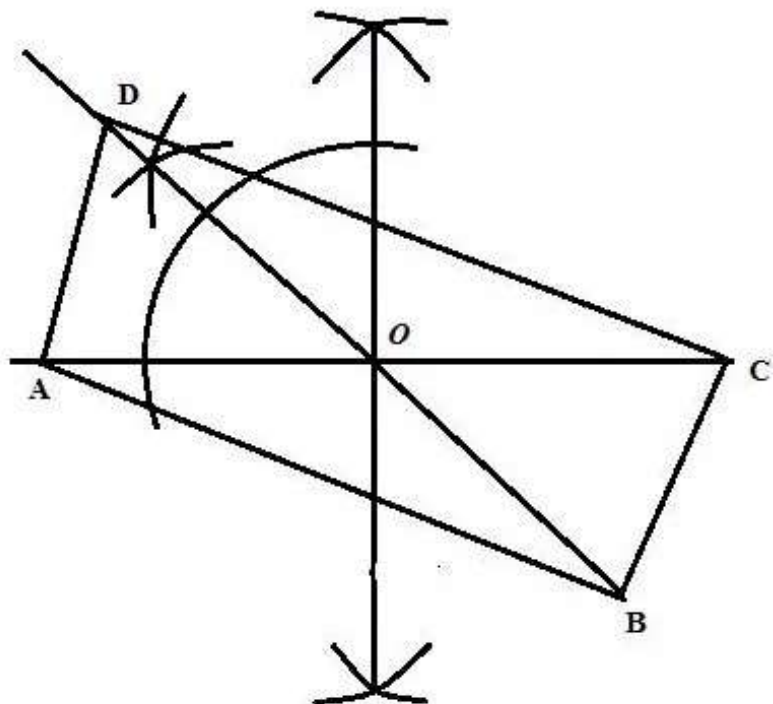

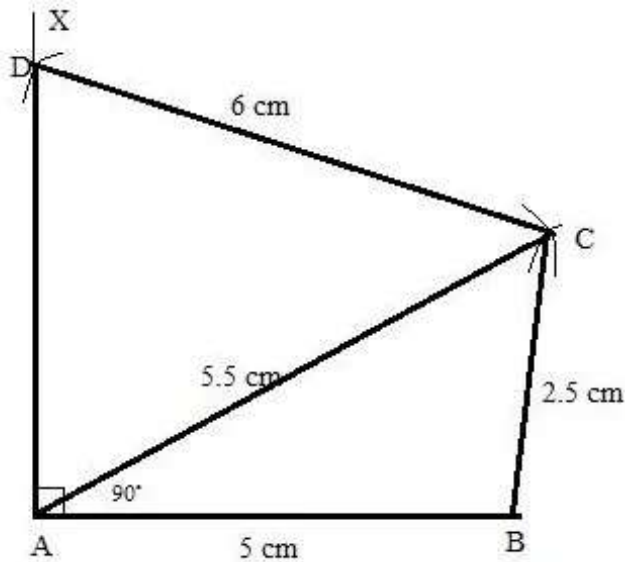
**Solution 33:**

Steps:

1. draw  $AB = 5\text{ cm}$ .
2. Now draw  $\angle XAB$  such that it is  $90^\circ$ .
3. Taking A and B as a centre and radius 2.5 cm and 5.5 cm draw arcs cuts off at C.
4. Now join BC and AC.
5. Taking C as a centre and radius 6 cm draw arcs at D on AX.

ABCD is the required quadrilateral.

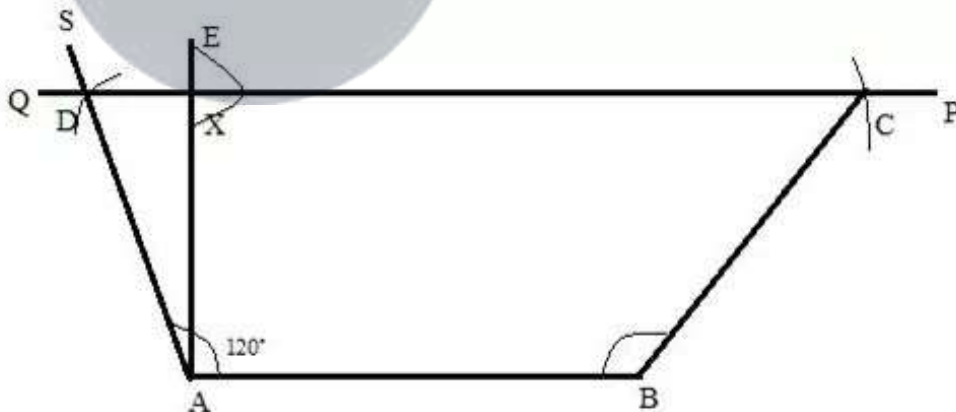
**Solution 34:**

Steps:

1. Draw  $AB = 4.5\text{ cm}$ .
2. now draw  $\angle BAS = 120^\circ$  and draw  $EA \perp AB$  such that  $AX = 3.3\text{ cm}$ .
3. Through X draw a line QR which is parallel to AB which cuts AS at D.
4. Through B draw an arc taking radius 3.6 cm at C on PQ.
5. Join CB.

ABCD is the required trapezium.

**Solution 35:**

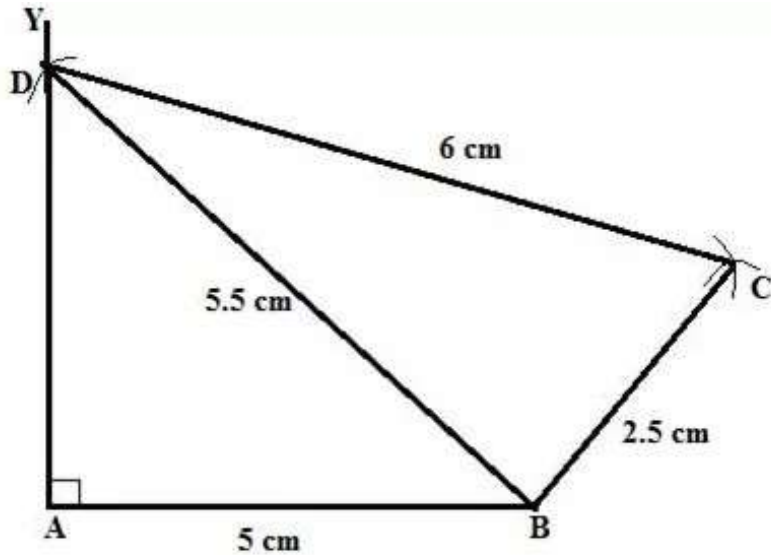

Steps:

1. Draw  $AB = 5\text{ cm}$ .
2. From A draw a line AY such that  $\angle A = 90^\circ$ .
3. Taking B as a centre with radius 5.5 cm draw an arc at D on AY.
4. With D and B as centre and radii 6 cm and 2.5 cm draw arcs cutting each other at C.
4. Join DC and BC.

ABCD is the required quadrilateral.

**Solution 36:**

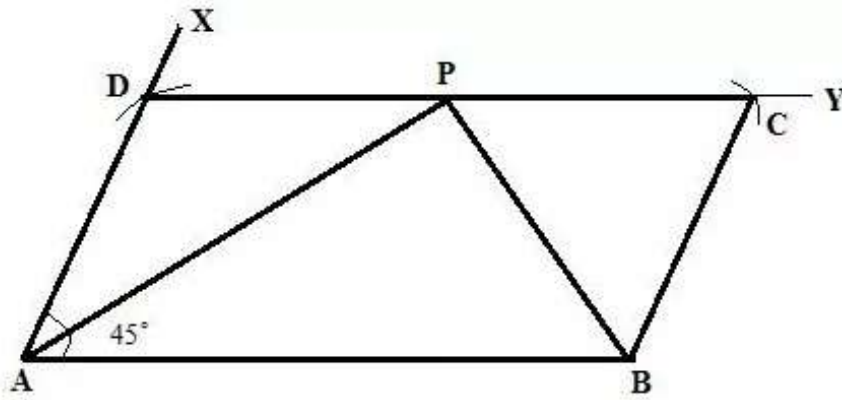

Steps:

1. draw  $AB=6\text{cm}$ .
2. With A as a centre draw a line AX such that  $\angle BAX = 45^\circ$ .
3. With A as a centre and radii 3 cm draw an arc on AD.
4. now with D and B as a centre and radii 6 cm and 3 cm draw arcs cutting each other at C.
5. Join DC and BC.

ABCD is the required parallelogram.

Here

$$\angle PAB = \angle APD \quad [\text{Alternate angles}]$$

$$\angle CPB = \angle PBA \quad [\text{Alternate angles}]$$

Now,

$$\angle DPA + \angle APB + \angle CPB = 180^\circ \dots\dots (i)$$

Also, considering  $\triangle APB$ ,

$$\angle PAB + \angle PBA + \angle APB = 180^\circ \dots\dots (ii)$$

Therefore, from (i) and (ii)

$$\angle APB = 90^\circ$$

Hence proved.

### Solution 37:

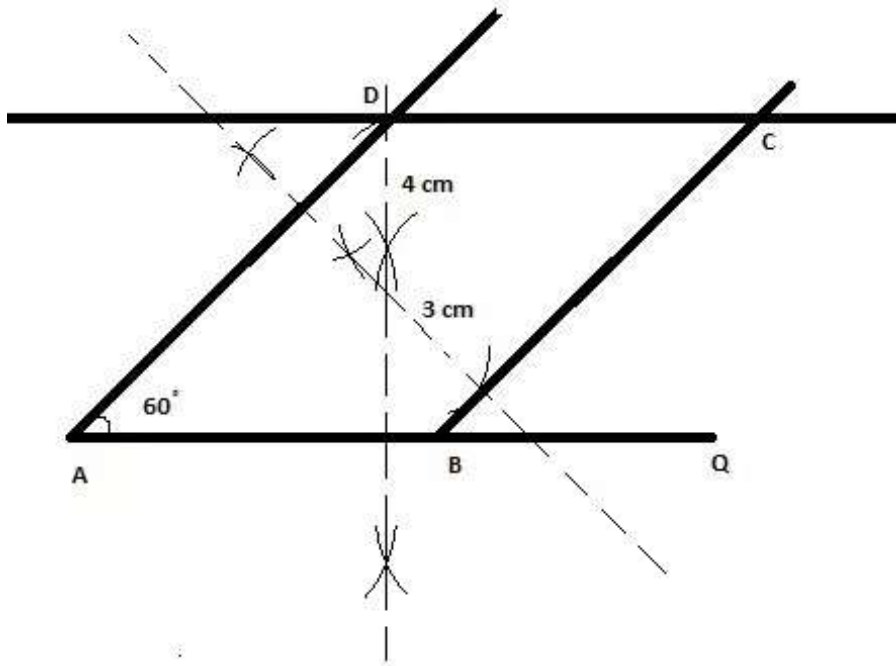

Steps:

1. Draw a base line AQ.
2. From A take some random distance in compass and draw one arc below and above the line. Now without changing the distance in compass draw one arc below and above the line. These arcs intersect each other above and below the line.
3. Draw the line passing through these intersecting points, you will get a perpendicular to the line AQ.
4. Take distance of 4 cm in compass and mark an arc on the perpendicular above the line. Draw a line parallel to line AQ passing through this arc.
5. From point A measure an angle of 60 degree and draw the line which intersects above drawn line at some point label it as D.
6. Using the procedure given in step 2 again draw a perpendicular to line AD.
7. Take distance of 3 cm in compass and mark an arc on the perpendicular above the line. Draw a line parallel to line AD passing through this arc which intersects the line AQ at some point label it as B and to other line at point C.

ABCD is the required parallelogram.

### Solution 38:

To draw the parallelogram follows the steps:

1. First draw a line AB of measure 6cm. Then draw an angle of measure  $45^{\circ}$  at point A such that  $\angle DAB = 45^{\circ}$  and  $AD = 5\text{cm}$ .
2. Now draw a line CD parallel to the line AB of measure 6cm. Then join BC to construct the parallelogram as shown below:

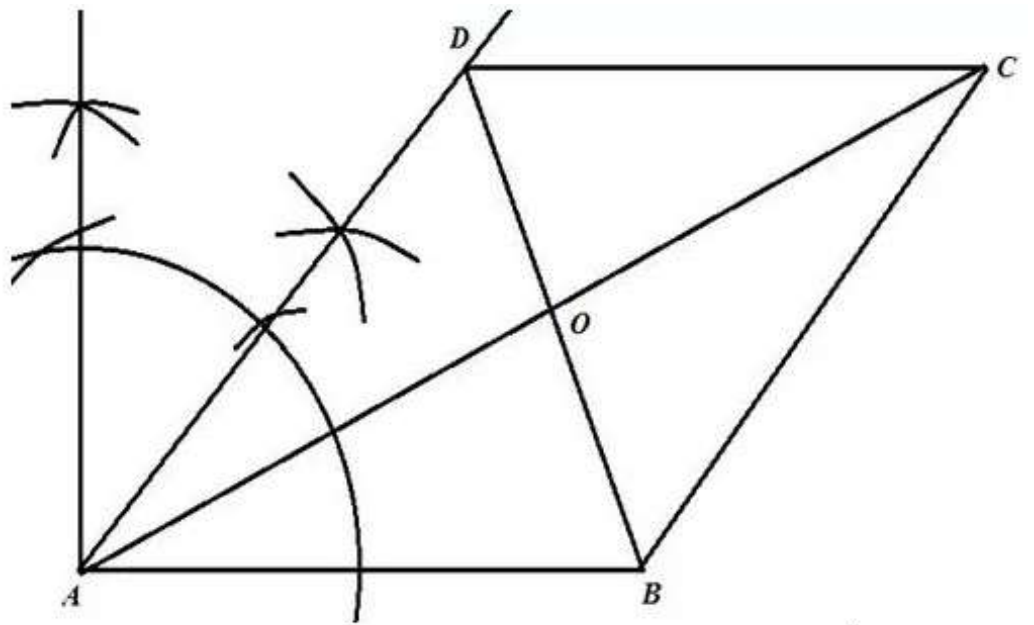

Now it is given that E is the midpoint of BC. We join OE. Now we are to prove that  $OE \parallel AB$  and  $OE = \frac{1}{2} AB$ .

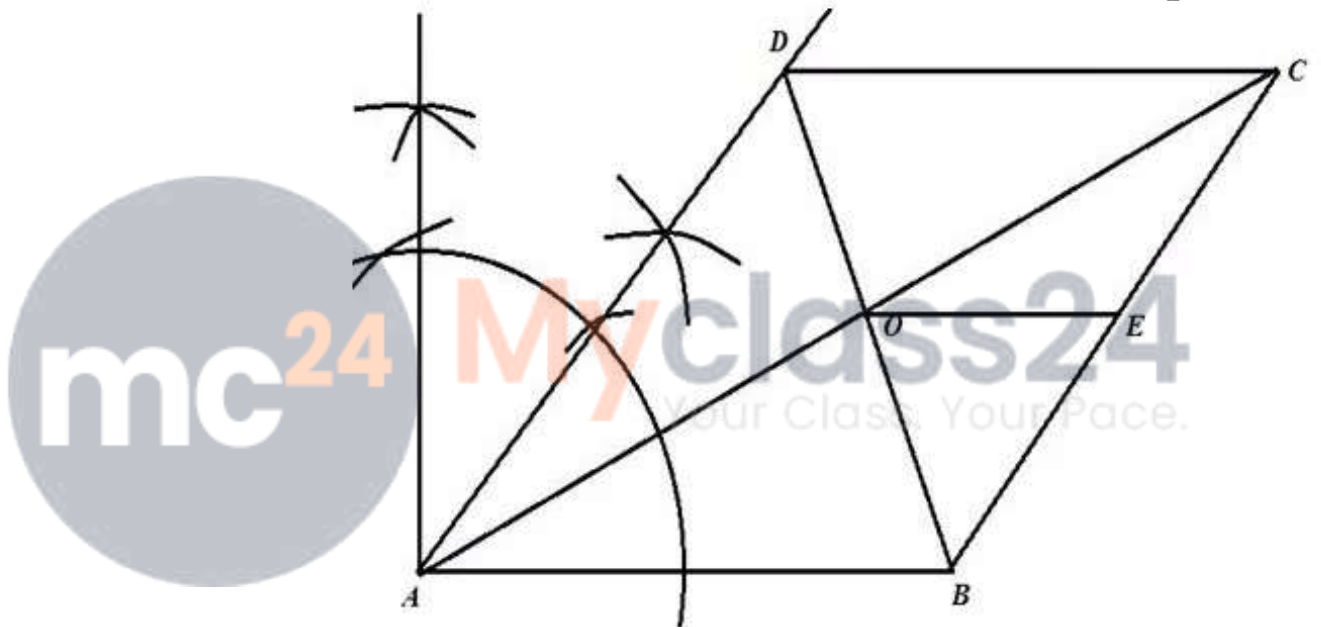

Since O is the midpoint of AC and E is the midpoint of BC, therefore the line is parallel to AB and  $OE = \frac{1}{2} AB$

**Solution 39:**

To draw the rectangle follows the steps:

(1) First draw a line  $AC$  of measure  $6\text{cm}$ .

(2) Then draw the perpendicular bisector of  $AC$  through  $O$ .

(3) At  $O$  draw an angle of measure  $45^\circ$ . Then produce  $OD$  of measure  $3\text{cm}$  and  $OB$  of measure  $3\text{cm}$  each.

(4) Now join  $AD$ ,  $AB$ ,  $BC$  and  $CD$  to form the rectangle.

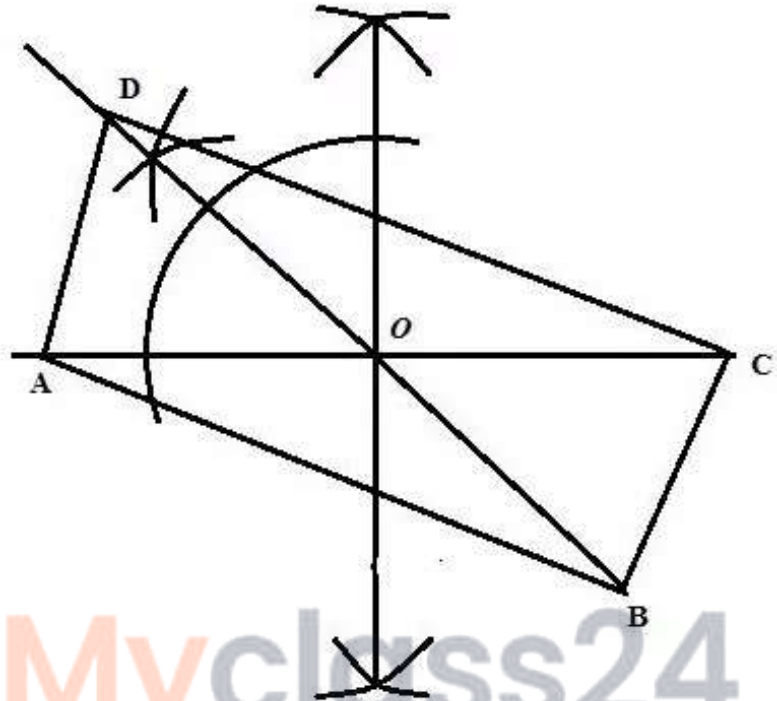

**Myclass24**  
Your Class. Your Pace.