

EXPERIMENT 6

AIM

To determine the resistance of a galvanometer by half-deflection method and to find its figure of merit.

APPARATUS AND MATERIAL REQUIRED

A moving coil galvanometer, a battery or a battery eliminator (0 - 6 V), one resistance box ($R_{\text{BOX 1}}$) of range 0 - 10 k Ω , one resistance box ($R_{\text{BOX 2}}$) of range 0 - 200 Ω , two one way keys, voltmeter, connecting wires and a piece of sand paper.

PRINCIPLE

Galvanometer

Galvanometer is a sensitive device used to detect very low current. Its working is based on the principle that a coil placed in a uniform magnetic field experiences a torque when an electric current is set up in it. The deflection of the coil is determined by a pointer attached to it, moving on the scale.

When a coil carrying current I is placed in a radial magnetic field, the coil experiences a deflection θ which is related to I as

$$I = k \theta$$

where k is a constant of proportionality and is termed as figure of merit of the galvanometer.

The circuit arrangement required for finding the resistance G of the galvanometer by half deflection method is shown in Fig. E 6.1.

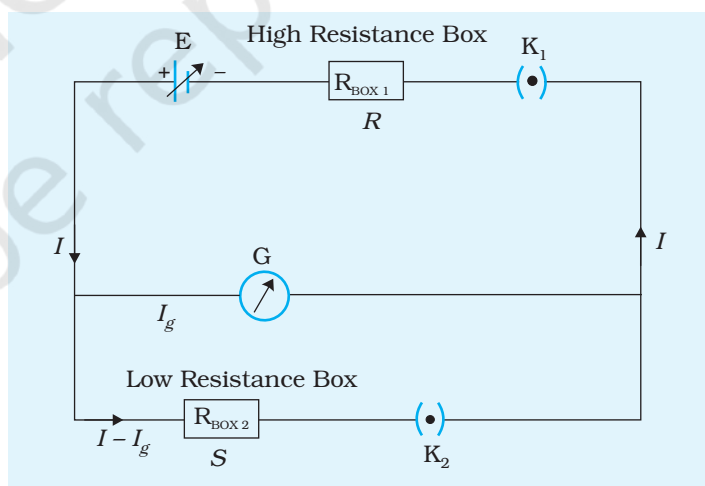

Fig. E 6.1 Circuit for finding resistance of galvanometer

(E 6.1)

When a resistance R is introduced in the circuit, the current I_g flowing through it is given by

$$(E\ 6.2) \quad I_g = \frac{E}{R + G}$$

In this case, the key K_2 is kept open. Here E is the emf of battery, G is the resistance of the galvanometer whose resistance is to be determined.

If the current I_g produces a deflection θ in the galvanometer, then from equation (E 6.1) we get

$$(E\ 6.3) \quad I_g = k\theta$$

Combining equations (E 6.2) and (E 6.3) we get

$$(E\ 6.4) \quad \frac{E}{R + G} = k\theta$$

On keeping both the keys K_1 and K_2 closed and by adjusting the value of shunt resistance S , the deflection of the galvanometer needle becomes $\frac{1}{2}$ (half). As G and S are in parallel combination and R in series with it, the total resistance of the circuit

$$(E\ 6.5) \quad R' = R + \frac{GS}{G + S}$$

The total current, I due to the emf E in the circuit is given by

$$(E\ 6.6) \quad I = \frac{E}{R + \frac{GS}{G + S}}$$

If I'_g is the current through the galvanometer of resistance G , then

$$GI'_g = S(I - I'_g)$$

$$(E\ 6.7) \quad \text{or,} \quad I'_g = \frac{IS}{G + S}$$

Substituting the value of I from Equation (E 6.6), in equation (E 6.7) the current I'_g is given by

$$\left[I'_g = \frac{IS}{G+S} = \frac{E}{R + \frac{GS}{G+S}} \cdot \frac{S}{G+S} \right]$$

$$I'_g = \frac{ES}{R(G+S) + GS} \quad \text{(E 6.8)}$$

For galvanometer current I'_g , if the deflection through the galvanometer is reduced to half of its initial value $\left(= \frac{\theta}{2} \right)$ then

$$I'_g = k \left(\frac{\theta}{2} \right) = \frac{ES}{R(G+S) + GS}$$

On dividing Eq. (E 6.2) by Eq. (E 6.8),

$$\frac{I_g}{I'_g} = \frac{E}{R+G} \times \frac{R(G+S) + GS}{ES} = 2$$

$$\text{or, } R(G+S) + GS = 2S(R+G)$$

$$\Rightarrow RG = RS + GS$$

$$\Rightarrow G(R-S) = RS$$

$$\text{or, } G = \frac{RS}{R-S} \quad \text{(E 6.9)}$$

By knowing the values of R and S , the galvanometer resistance G can be determined. Normally R is chosen very high ($\sim 10 \text{ k}\Omega$) in comparison to S ($\sim 100 \Omega$) for which

$$G \approx S$$

The figure of merit (k) of the galvanometer is defined as the current required for deflecting the pointer by one division. That is

$$k = \frac{I}{\theta} \quad \text{(E 6.10)}$$

For determining the figure of merit of the galvanometer the key K_2 is opened in the circuit arrangement.

Using Eqs. (E 6.2) and (E 6.3) the figure of merit of the galvanometer is given by

$$k = \frac{1}{\theta} \left(\frac{E}{R+G} \right), \quad \text{(E 6.11)}$$

By knowing the values of E , R , G and θ the figure of merit of the galvanometer can be calculated.

PROCEDURE

1. Clean the connecting wires with sand paper and make neat and tight connections as per the circuit diagram (Fig. E 6.1).
2. From the high resistance box ($R_{\text{BOX 1}}$) (1-10 k Ω), remove 5 k Ω key and then close the key K_1 . Adjust the resistance R from this resistance box to get full scale deflection on the galvanometer dial. Record the values of resistance, R and deflection θ .
3. Insert the key K_2 and keep R fixed. Adjust the value of shunt resistance S to get the deflection in the galvanometer which is exactly half of θ . Note down S . Remove plug K_2 after noting down the value of shunt resistance, S .
4. Take five sets of observations by repeating steps 2 and 3 so that θ is even number of divisions and record the observations for R , S , θ and $\frac{\theta}{2}$ in tabular form.
5. Calculate the galvanometer resistance G and figure of merit k of galvanometer using Eqs. (E 6.9) and (E 6.11) respectively.

OBSERVATIONS

Emf of the battery $E = \dots$ V

Number of divisions on full scale of galvanometer = ...

Table E 6.1: Resistance of galvanometer

Sl. No.	High Resistance	Deflection in the galvanometer	Shunt resistance	Half deflection in the galvanometer	$G = \frac{R \cdot S}{R - S}$	$k = \frac{E}{R + G} \cdot \frac{1}{\theta}$
	R (Ω)	θ (divisions)	S (Ω)	$\frac{\theta}{2}$ (divisions)	(Ω)	A/divisions
1						
2						
...						
5						

CALCULATIONS

Mean value of G (resistance of galvanometer) = ... Ω

Mean value of k (figure of merit of galvanometer) = ... ampere/division.

RESULT

1. Resistance of galvanometer by half deflection method, $G = \dots \Omega$
2. Figure of merit of galvanometer, $k = \dots$ ampere/division

PRECAUTIONS

1. Key K_1 should be inserted only after high value of R has been taken out from resistance box otherwise galvanometer coil may burn.
2. Adjust R such that deflection in galvanometer is of even division so that $\theta/2$ is more conveniently obtained.
3. Emf of the battery should be constant.
4. Use as high values of R as practically possible. This ensures correct value of G .
5. All the connections and plugs in the resistance box should be tight.

SOURCES OF ERRORS

1. Plugs in the resistance boxes may be loose or they may not be clean.
2. The emf of the battery may not be constant.

DISCUSSION

1. By closing the key K_2 and adjusting the value of resistance in resistance box $R_{\text{BOX } 2}$, you get the deflection $\theta/2$ in the galvanometer. Then the resistance S equals G , the resistance of galvanometer, because half of the current passing through R is shared by S and half by galvanometer. It is noteworthy that R is so large compared to S or G that opening or closing the key K_2 makes insignificant difference in the current passing through R .
2. We define current sensitivity C of the galvanometer as the deflection produced per unit current. With K_2 open, the current passing through it is

$$C\theta = \frac{E}{R}$$

$$C = \frac{E}{R\theta}$$

3. From eq. E 6.9, $RS = G(R - S)$. Galvanometer resistance G can also be determined from the slope of a graph plotted RS against $(R - S)$ with RS on y-axis and $(R - S)$ on x-axis.

SELF ASSESSMENT

- How will you use a galvanometer for measuring current?
- Out of galvanometer, ammeter and voltmeter which has the highest resistance and which has the lowest? Explain.
 - Which of the two meters has lower resistance – a milliammeter or a microammeter?
- What are the factors on which sensitivity of a galvanometer depends?
- Internal resistance of the cell is taken to be zero. This implies that we have to use a freshly charged accumulator in the experiment or use a good battery eliminator. If the internal resistance is finite, how will it affect the result?
- Is it possible to find the galvanometer resistance by taking $1/3$ deflection? If so what changes would be required in the formula for calculation of value of G .

SUGGESTED ADDITIONAL EXPERIMENTS/ACTIVITIES

- Plot a graph between R and $\frac{1}{\theta}$ (R along x-axis). Use the graph to determine G and k .
- Plot a graph of θ against $\left(\frac{E}{R+G}\right)$ with θ on y-axis and $\left(\frac{E}{R+G}\right)$ on x-axis.
How will you determine k from the graph?
- Use the values of G and k to calculate the value of shunt resistance required to convert the given galvanometer into an ammeter of 0 - 3 A range.
- Calculate the value of series resistance required to convert the given galvanometer into a voltmeter of 0 - 30 V range.

EXPERIMENT 7

A_{IM}

To convert the given galvanometer (of known resistance and figure of merit) into (i) an ammeter of a desired range (say 0 to 30 mA) and (ii) a voltmeter of desired range (say 0 to 3 V) and to verify the same.

A_{PPARATUS AND MATERIAL REQUIRED}

A galvanometer of known resistance and figure of merit, a constantan or manganin wire of 26 or 30 SWG, a battery or a battery eliminator, one way key, a rheostat of range 200 Ω , an ammeter of 0-30 mA range, a voltmeter of 3 V range, connecting wires and sand paper.

(i) P_{RINCIPLE (CONVERSION OF GALVANOMETER INTO AN AMMETER)}

A galvanometer is a sensitive device which can detect the presence of very small current in a circuit of the order of 100 μ A. For measuring current of the order of an ampere, a low resistance called shunt resistance S is connected in parallel across the galvanometer having resistance G .

If I_0 is the total current in the circuit for full scale deflection, then the current $(I_0 - I_g)$ passes through S , where I_g is current that flows through the galvanometer for full scale deflection. The instrument is calibrated so as to read the current directly in ampere and then it can be used as an ammeter. Since G and S are parallel to each other therefore, the potential difference across both are same, hence,

$$I_g G = (I_0 - I_g) S \quad \text{(E 7.1)}$$

$$\text{or } S = \frac{I_g G}{I_0 - I_g} \quad \text{(E 7.2)}$$

The figure of merit of the galvanometer is represented by the symbol k which represents the current corresponding to one scale division; thus if N is the total number of divisions (on either side) of the galvanometer scale, the value of current I_g is given by

$$I_g = kN$$

if n represents the actual deflection in the converted galvanometer, then the total current will be

$$I = n \frac{I_o}{N}$$

PROCEDURE

1. Determine the galvanometer resistance G and figure of merit k as per the procedure given in experiment 6.
2. Count the total number of divisions N on either side of zero of the galvanometer scale.
3. Calculate the current I_g for full scale deflection in the galvanometer by using the relation $I_g = Nk$, where k is the figure of merit of the galvanometer.

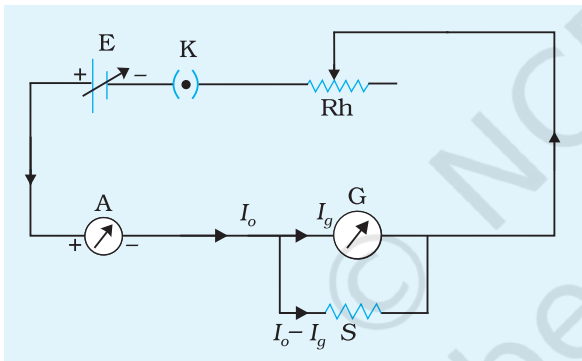

Fig. E 7.1 Circuit to verify conversion of galvanometer into an ammeter

4. Calculate the shunt resistance S using the formula $S = \frac{I_g G}{I_o - I_g}$.

5. Measure the radius r of the wire and from the given value of the specific resistance ρ , calculate the length of the wire l , for resistance S [use the formula $l = \frac{S\pi r^2}{\rho}$].

6. Let the calculated length of the wire be 10 cm. Then cut 3-4 cm extra and put it in parallel to the galvanometer and complete the circuit as shown in Fig. E 7.1.

7. Adjust the length of the wire so that when we see full scale deflection in the galvanometer, the current in the ammeter is 30 mA.
8. Thus the galvanometer is now converted to an ammeter whose range is 30 mA.
9. Now measure the exact length of the shunt wire and calculate its resistance by using the previously measured value of radius and the known value of specific resistance.

10. Compare the above value of resistance to the one calculated using

the formula $S = \frac{l \times \rho}{\pi r^2}$.

OBSERVATIONS

- Galvanometer resistance, G (given) = ... Ω
- Figure of merit of the galvanometer, k (given) = ... ampere/division
- Number of divisions on either side of zero of the galvanometer scale, N = ... division
- Current required for producing full scale deflection of N divisions, $I_g = k N$ = ... ampere
- Radius of wire:

Least count of the given screw gauge = ... cm

Zero error = ... cm

Zero correction = ... cm

Observed diameter of the wire:

- | | |
|--------------|-------------|
| (i) ... cm | (ii) ... cm |
| (iii) ... cm | (iv) ... cm |

Mean observed diameter, D = ... cm

Radius of the wire $r = D/2$ = ... cm

CALCULATIONS

- Shunt resistance = $S = \frac{I_g G}{I_0 - I_g} = \dots \Omega$
- Given value of specific resistance of the material of the wire $\rho = \dots \Omega \text{ m}$
- Required length of wire, $l = \frac{S \pi r^2}{\rho} = \dots \text{ cm}$
- Observed length of the shunt wire for the desired range, $l' = \dots \text{ cm}$
- Shunt resistance from the observed length of the wire, $S' = \frac{l' \times \rho}{\pi r^2} = \dots \Omega$

RESULT

To convert the given galvanometer into an ammeter of the range, 0 to ... ampere

1. the calculated resistance of the shunt wire, $S = \dots \Omega$
2. the observed resistance of the shunt wire, $S' = \dots \Omega$

P RECAUTIONS

1. Use the ammeter for verification which has the same range as the range of conversion.
2. Cut about 3 to 4 cm extra to the calculated length of the wire.
3. After adjusting the length of the wire, measure the length of the wire between the two plugs carefully.

(ii) P RINCIPLE (CONVERSION OF GALVANOMETER INTO A VOLTMETER)

By connecting a high resistance of suitable value in series with a galvanometer, it is converted into a voltmeter. Voltmeter is always connected in parallel with the electrical component across which potential difference is to be measured.

If a galvanometer (having resistance G) shows a full scale deflection for a maximum current I_g , the potential difference across the galvanometer is $I_g G$. If the converted galvanometer is desired to have a range V_o volt, then the resistance to be joined in series with

galvanometer, is given by $R = \frac{V_o}{I_g} - G$.

P ROCEDURE

1. Calculate the value of the series resistance R for given values of V_o , I_g and G .
2. Make the connections as shown in Fig. E 7.2 by connecting a cell and converted galvanometer and the voltmeter of nearly the same range in parallel, with a high resistance rheostat R_h .
3. Close the key K and adjust the rheostat so that the voltage shown in the voltmeter is equal to the desired range (say 3 V). Simultaneously, adjust the position of the slider of the rheostat and also the resistance from the resistance box so that when full scale deflection is observed on the galvanometer, the voltmeter shows 3 V. Note the total resistance from the resistance box.

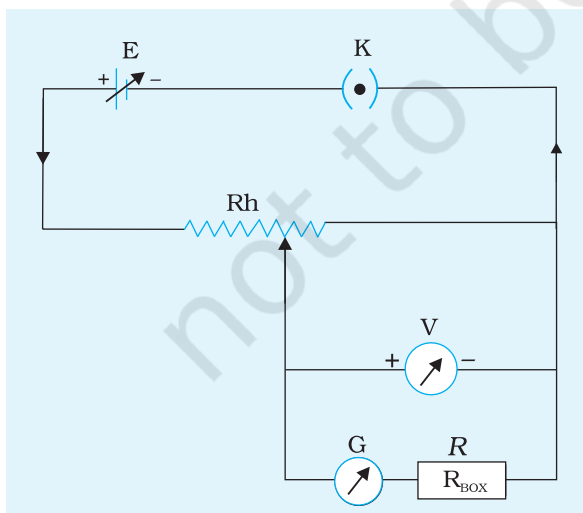

Fig. E 7.2 Circuit to verify conversion of galvanometer into a voltmeter

OBSERVATIONS

1. Resistance of the galvanometer, G (given) = ... Ω
2. The figure of merit of the galvanometer, k (given) = ... ampere/division
3. Number of divisions on either side of zero of the galvanometer scale, N = ... division
4. Current required for producing full scale deflection of N divisions, $I_g = kN$ = ... ampere
5. Total resistance taken out from the resistance box = ... Ω

CALCULATIONS

Resistance to be connected in series with the galvanometer,

$$R = \frac{V_0}{I_g} - G = \dots \Omega$$

RESULT

To convert the given galvanometer into a voltmeter of the range,

0 to ... V

1. The value of the calculated series resistance, R = ... Ω
2. The value of the observed series resistance, R' = ... Ω
3. Current for full scale deflection, I_g = ...ampere

PRECAUTIONS

1. The resistance box used should be of high resistance.
2. The rheostat should be used as potential divider.
3. High resistance of the order of 10 k Ω from the resistance box should be used first and then the battery key should be closed to avoid any damage to the galvanometer.

SOURCES OF ERROR

The wire may be of non-uniform area of cross section.

DISCUSSION

1. If the area of cross section of the wire is non-uniform, how will it affect the observation?
2. Use a rheostat as current divider and potential divider.
3. To check if friction in your instrument is small enough, measure θ in the same setting 5 to 10 times. If each time, the needle comes to exactly the same point on the scale, friction in your instrument is quite small.

SELF ASSESSMENT

1. How can you increase the range of the converted galvanometer to 0-60 mA?
2. How can you decrease the range of the converted galvanometer to 0-20 mA?
3. If $S \ll G$, what is the order of resistance of converted galvanometer?
4. Why is an ammeter always connected in series with the circuit?
5. Why is a voltmeter always connected in parallel with the circuit?

SUGGESTED ADDITIONAL EXPERIMENTS/ACTIVITIES

1. Calculate the length of the wire of same material if the radius is doubled.
2. Calculate the length of the wire if the radius is same but material used is copper.
3. Change the range of ammeter and voltmeter and repeat the same procedure as followed in the above experiment.
4. Use the converted ammeter/voltmeter for verification which has the same range as the range of conversion.