

## EXERCISE 11.4

The area of a circular playground is  $22176 \text{ m}^2$ . Find the cost of fencing this ground at the rate of Rs 50 per metre.

**Solution:**

According to the question,

Area of the circular playground =  $22176 \text{ m}^2$  (Given)

Let  $r$  be the radius of the circle.

$$\therefore \pi r^2 = 22176$$

$$\Rightarrow (22/7)r^2 = 22176$$

$$\Rightarrow r^2 = 22176 \times (22/7)$$

$$\Rightarrow r^2 = 7056$$

$$\Rightarrow r = 84$$

$\therefore$  Radius of the circular playground = 84 m

Now, circumference of the circle =  $2\pi r$

$$= 2 \times (22/7) \times 84$$

$$= 528 \text{ m}$$

Cost of fencing 1 meter of ground = Rs 50

$\therefore$  Cost of fencing the total ground =  $\text{Rs } 528 \times 50 = \text{Rs } 26,400$

1. The diameters of front and rear wheels of a tractor are 80 cm and 2 m respectively. Find the number of revolutions that rear wheel will make in covering a distance in which the front wheel makes 1400 revolutions.

**Solution:**

According to the question,

Diameter of front wheels =  $d_1 = 80 \text{ cm}$

Diameter of rear wheels =  $d_2 = 2 \text{ m} = 200 \text{ cm}$

Let  $r_1$  be the radius of the front wheels =  $80/2 = 40 \text{ cm}$

Let  $r_2$  be the radius of the rear wheels =  $200/2 = 100 \text{ cm}$

Now, Circumference of the front wheels =  $2\pi r$

$$= 2 \times (22/7) \times 40$$

$$= 1760/7 \text{ cm}$$

Circumference of the rear wheels =  $2\pi r = 2 \times (22/7) \times 100 = 4400/7 \text{ cm}$

No. of revolutions made by the front wheel = 1400

$\therefore$  Distance covered by the front wheel =  $1400 \times (1760/7) = 352000 \text{ cm}$

Number of revolutions made by rear wheel in covering a distance in which the front wheel makes 1400 revolutions,

$$\frac{\text{Distance covered by front wheel}}{\text{Circumference of the rear wheel}}$$

$$= \frac{352000}{4400}$$

$$= \frac{7}{7}$$

$$= \frac{352000 \times 7}{4400}$$

$$= 560 \text{ revolutions.}$$

2. Sides of a triangular field are 15 m, 16 m and 17 m. With the three corners of the field a cow, a buffalo and a horse are tied separately with ropes of length 7 m each to graze in the field. Find the area of the field which cannot be grazed by the three animals.

## Class 10 Maths Chapter 11-Area Related To Circles

### Solution:

According to the question,

Sides of the triangle are 15 m, 16 m, and 17 m.

Now, perimeter of the triangle =  $(15+16+17)$  m = 48 m

$\therefore$  Semi-perimeter of the triangle =  $s = 48/2 = 24$  m

By Heron's formula,

Area of the triangle =  $\sqrt{(s(s-a)(s-b)(s-c))}$  , here a, b and c are the sides of triangle

=  $\sqrt{(24(24-15)(24-16)(24-17))}$

= 109.982 m<sup>2</sup>

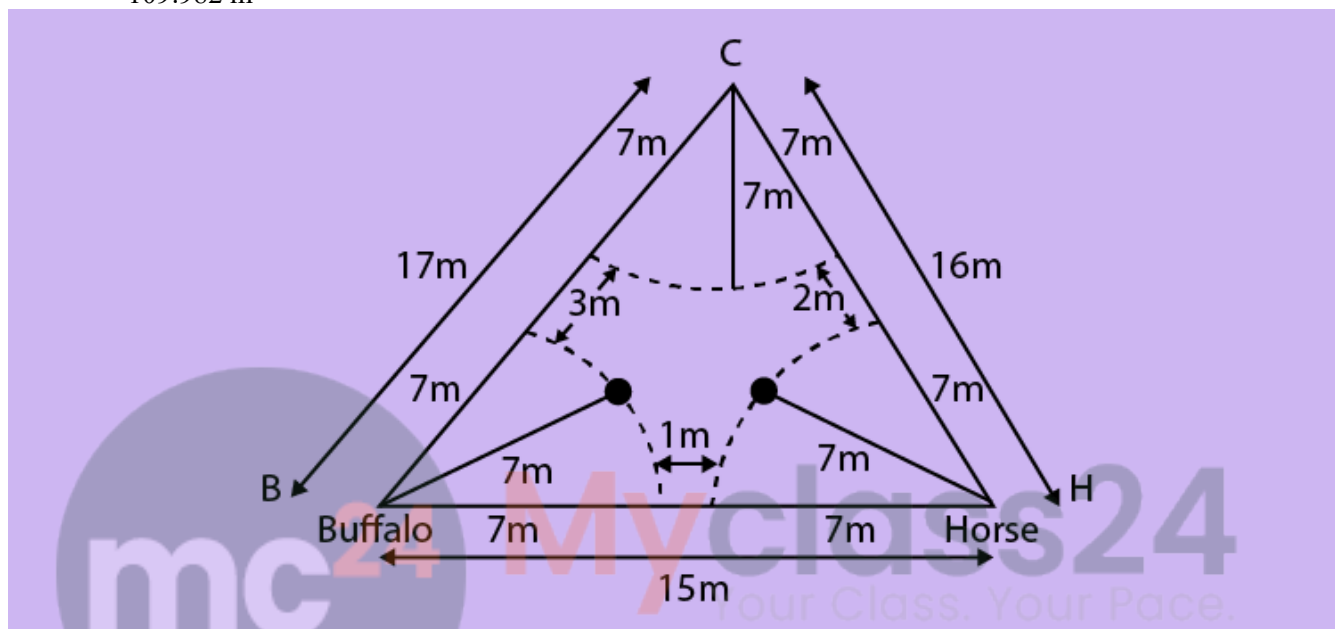

Let B, C and H be the corners of the triangle on which buffalo, cow and horse are tied respectively with ropes of 7 m each.

So, the area grazed by each animal will be in the form of a sector.

$\therefore$  Radius of each sector =  $r = 7$  m

Let  $x, y, z$  be the angles at corners B, C, H respectively.

$\therefore$  Area of sector with central angle  $x$ ,  
=  $\frac{1}{2} \left(\frac{x}{180}\right) \times \pi r^2 = \left(\frac{x}{360}\right) \times \pi(7)^2$

Area of sector with central angle  $y$ ,  
=  $\frac{1}{2} \left(\frac{y}{180}\right) \times \pi r^2 = \left(\frac{y}{360}\right) \times \pi(7)^2$

Area of sector with central angle  $z$ ,  
=  $\frac{1}{2} \left(\frac{z}{180}\right) \times \pi r^2 = \left(\frac{z}{360}\right) \times \pi(7)^2$

Area of field not grazed by the animals = Area of triangle – (area of the three sectors)

$$= (109.982) - \left( \left(\frac{x}{360}\right) \times \pi(7)^2 + \left(\frac{y}{360}\right) \times \pi(7)^2 + \left(\frac{z}{360}\right) \times \pi(7)^2 \right)$$

$$= 109.982 - \left( \left(\frac{x+y+z}{360}\right) \times \pi(7)^2 \right)$$

$$= 109.982 - \left( \left(\frac{180}{360}\right) \times \left(\frac{22}{7}\right) \times 49 \right)$$

$$= 109.892 - 77$$

$$= 32.982 \text{ cm}^2$$

**3. Find the area of the segment of a circle of radius 12 cm whose corresponding sector has a central angle of  $60^\circ$  (Use  $\pi = 3.14$ ).**

**Solution:**

According to the question,  
 Radius of the circle =  $r = 12$  cm  
 $\therefore OA = OB = 12$  cm  
 $\angle AOB = 60^\circ$  (given)

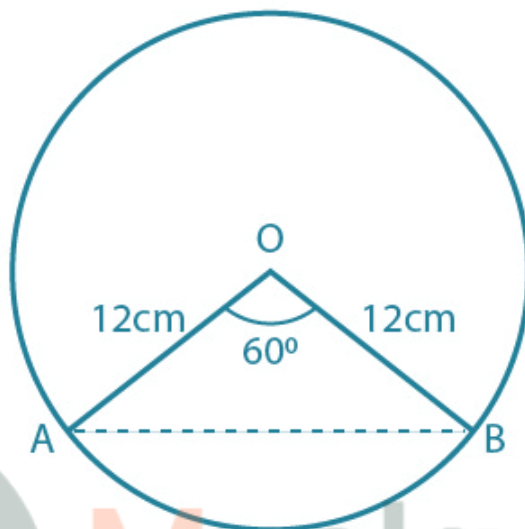

Since triangle OAB is an isosceles triangle,  $\therefore \angle OAB = \angle OBA = \theta$  (say)

Also, Sum of interior angles of a triangle is  $180^\circ$ ,

$$\therefore \theta + \theta + 60^\circ = 180^\circ$$

$$\Rightarrow 2\theta = 120^\circ \Rightarrow \theta = 60^\circ$$

Thus, the triangle AOB is an equilateral triangle.

$$\therefore AB = OA = OB = 12 \text{ cm}$$

Area of the triangle AOB =  $(\sqrt{3}/4) \times a^2$ , where  $a$  is the side of the triangle.

$$= (\sqrt{3}/4) \times (12)^2$$

$$= (\sqrt{3}/4) \times 144$$

$$= 36\sqrt{3} \text{ cm}^2$$

$$= 62.354 \text{ cm}^2$$

Now, Central angle of the sector AOB =  $\theta = 60^\circ = (60\pi / 180) = (\pi/3)$  radians

Thus, area of the sector AOB =  $\frac{1}{2} r^2 \theta$

$$= \frac{1}{2} \times 12^2 \times \pi/3$$

$$= 12^2 \times (22 / (7 \times 6))$$

$$= 75.36 \text{ cm}^2$$

Now, Area of the segment ABCA = Area of the sector AOB - Area of the triangle AOB

$$= (75.36 - 62.354) \text{ cm}^2 = 13.006 \text{ cm}^2$$

**4. A circular pond is 17.5 m in diameter. It is surrounded by a 2 m wide path. Find the cost of constructing the path at the rate of Rs 25 per  $\text{m}^2$**

**Solution:**

Diameter of the circular pond = 17.5 m

## Class 10 Maths Chapter 11-Area Related To Circles

Let  $r$  be the radius of the park =  $(17.5/2)$  m = 8.75 m

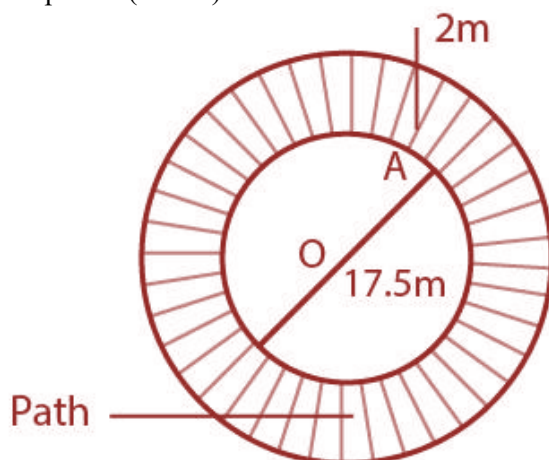

According to the question,

The circular pond is surrounded by a path of width 2 m.

So, Radius of the outer circle =  $R = (8.75+2)$  m = 10.75 m

Area of the road = Area of the outer circular path – Area of the circular pond

$$\begin{aligned} &= \pi r^2 - \pi R^2 \\ &= 3.14 \times (10.75)^2 - 3.14 \times (8.75)^2 \\ &= 3.14 \times ((10.75)^2 - (8.75)^2) \\ &= 3.14 \times ((10.75 + 8.75) \times (10.75 - 8.75)) \\ &= 3.14 \times 19.5 \times 2 = 122.46 \text{ m}^2 \end{aligned}$$

Hence, the area of the path is 122.46 m<sup>2</sup>.

Now, Cost of constructing the path per m<sup>2</sup> = Rs. 25

$\therefore$  cost of constructing 122.46m<sup>2</sup> of the path = Rs. 25  $\times$  122.46 = Rs. 3061.50

**5. In Fig. 11.17, ABCD is a trapezium with  $AB \parallel DC$ ,  $AB = 18$  cm,  $DC = 32$  cm and distance between  $AB$  and  $DC = 14$  cm. If arcs of equal radii 7 cm with centres A, B, C and D have been drawn, then find the area of the shaded region of the figure.**

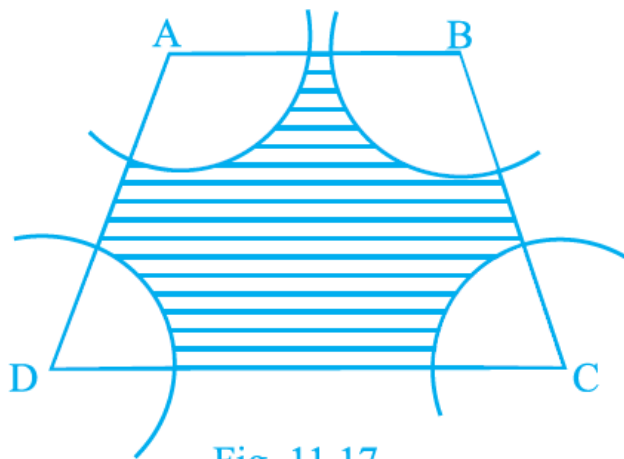

Fig. 11.17

**Solution:**

$AB = 18$  cm,  $DC = 32$  cm

Distance between  $AB$  and  $DC =$  Height = 14 cm

Now, Area of the trapezium =  $(1/2) \times (\text{Sum of parallel sides}) \times \text{Height}$

## Class 10 Maths Chapter 11-Area Related To Circles

$$= \left(\frac{1}{2}\right) \times (18+32) \times 14 = 350\text{cm}^2$$

As  $AB \parallel DC$ ,  $\therefore \angle A + \angle D = 180^\circ$

And  $\angle B + \angle C = 180^\circ$

Also, radius of each arc = 7 cm

Therefore,

Area of the sector with central angle A =  $\left(\frac{1}{2}\right) \times (\angle A/180) \times \pi \times r^2$

Area of the sector with central angle D =  $\left(\frac{1}{2}\right) \times (\angle D/180) \times \pi \times r^2$

Area of the sector with central angle B =  $\left(\frac{1}{2}\right) \times (\angle B/180) \times \pi \times r^2$

Area of the sector with central angle C =  $\left(\frac{1}{2}\right) \times (\angle C/180) \times \pi \times r^2$

Total area of the sectors,

$$= \frac{\angle A}{360} \times \pi \times r^2 + \frac{\angle D}{360} \times \pi \times r^2 + \frac{\angle B}{360} \times \pi \times r^2 + \frac{\angle C}{360} \times \pi \times r^2$$

$$= \left(\frac{\angle A + \angle D}{360} \times \pi \times r^2\right) + \left(\frac{\angle B + \angle C}{360} \times \pi \times r^2\right)$$

$$= \left(\frac{180}{360} \times \frac{22}{7} \times 49\right) + \left(\frac{180}{360} \times \frac{22}{7} \times 49\right)$$

$$= 77 + 77$$

$$= 154$$

$\therefore$  Area of shaded region = Area of trapezium – (Total area of sectors)

$$= 350 - 154 = 196 \text{ cm}^2$$

Hence, the required area of shaded region is  $196 \text{ cm}^2$ .

**6. Three circles each of radius 3.5 cm are drawn in such a way that each of them touches the other two. Find the area enclosed between these circles.**

**Solution:**

The three circles are drawn such that each of them touches the other two.

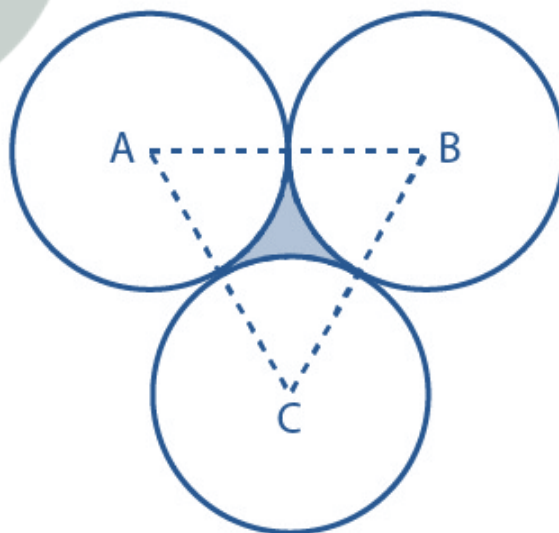

By joining the centers of the three circles,

We get,

$$AB = BC = CA = 2(\text{radius}) = 7 \text{ cm}$$

Therefore, triangle ABC is an equilateral triangle with each side 7 cm.

## Class 10 Maths Chapter 11-Area Related To Circles

$$\begin{aligned}\therefore \text{Area of the triangle} &= (\sqrt{3}/4) \times a^2, \text{ where } a \text{ is the side of the triangle.} \\ &= (\sqrt{3}/4) \times 7^2 \\ &= (49/4) \sqrt{3} \text{ cm}^2 \\ &= 21.2176 \text{ cm}^2\end{aligned}$$

$$\begin{aligned}\text{Now, Central angle of each sector} &= \phi = 60^\circ (60\pi/180) \\ &= \pi/3 \text{ radians}\end{aligned}$$

$$\begin{aligned}\text{Thus, area of each sector} &= (1/2) r^2 \theta \\ &= (1/2) \times (3.5)^2 \times (\pi/3) \\ &= 12.25 \times (22/7 \times 6) \\ &= 6.4167 \text{ cm}^2\end{aligned}$$

$$\text{Total area of three sectors} = 3 \times 6.4167 = 19.25 \text{ cm}^2$$

$$\begin{aligned}\therefore \text{Area enclosed between three circles} &= \text{Area of triangle ABC} - \text{Area of the three sectors} \\ &= 21.2176 - 19.25 \\ &= 1.9676 \text{ cm}^2\end{aligned}$$

Hence, the required area enclosed between these circles is  $1.967 \text{ cm}^2$  (approx.).

**7. Find the area of the sector of a circle of radius 5 cm, if the corresponding arc length is 3.5 cm.**

**Solution:**

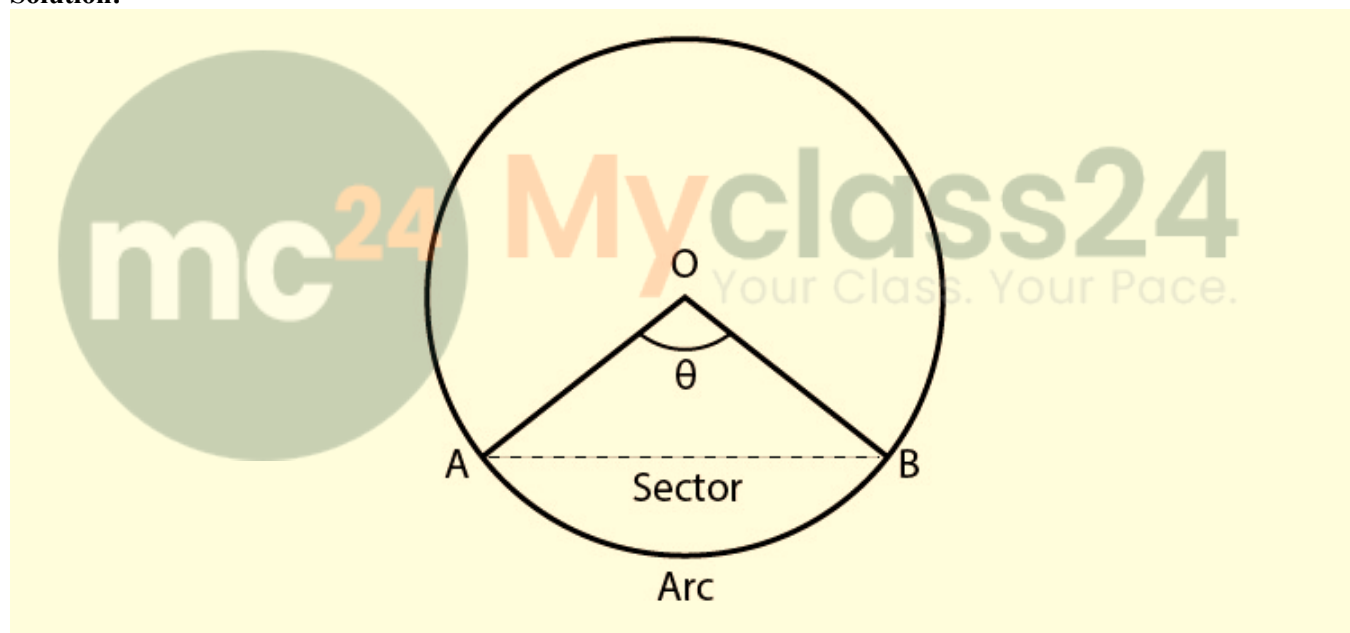

$$\text{Radius of the circle} = r = 5 \text{ cm}$$

$$\text{Arc length of the sector} = l = 3.5 \text{ cm}$$

Let the central angle (in radians) be  $\theta$ .

As, Arc length = Radius  $\times$  Central angle (in radians)

$$\therefore \text{Central angle } (\theta) = \text{Arc length} / \text{Radius} = l / r = 3.5/5 = 0.7 \text{ radians}$$

$$\text{Now, Area of the sector} = (1/2) \times r^2 \theta = (1/2) \times 25 \times 0.7 = 8.75 \text{ cm}^2$$

Hence, required area of the sector of a circle is  $8.75 \text{ cm}^2$ .

**8. Four circular cardboard pieces of radii 7 cm are placed on a paper in such a way that each piece touches other two pieces. Find the area of the portion enclosed between these pieces.**

**Solution:**

According to the question,

The four circles are placed such that each piece touches the other two pieces.

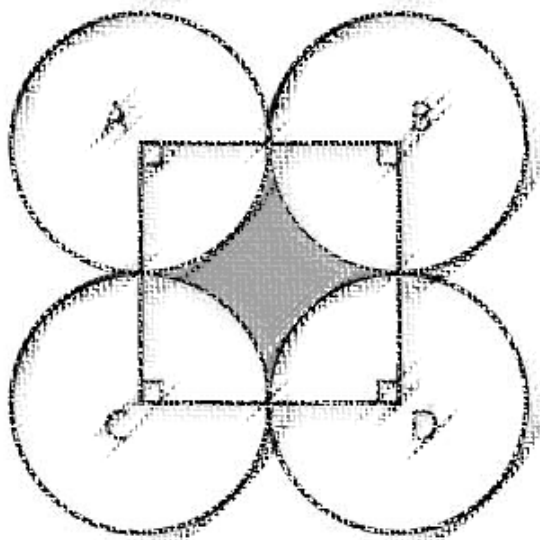

By joining the centers of the circles by a line segment, we get a square ABDC with sides,

$$AB = BD = DC = CA = 2(\text{Radius}) = 2(7) \text{ cm} = 14 \text{ cm}$$

$$\text{Now, Area of the square} = (\text{Side})^2 = (14)^2 = 196 \text{ cm}^2$$

ABDC is a square,

Therefore, each angle has a measure of  $90^\circ$ .

$$\text{i.e., } \angle A = \angle B = \angle D = \angle C = 90^\circ = \pi/2 \text{ radians} = \theta \text{ (say)}$$

Given that,

$$\text{Radius of each sector} = 7 \text{ cm}$$

$$\begin{aligned} \text{Area of the sector with central angle } A &= \frac{1}{2}r^2\theta \\ &= \frac{1}{2}r^2\theta \\ &= \frac{1}{2} \times 49 \times \pi/2 \\ &= \frac{1}{2} \times 49 \times (22/(2 \times 7)) \\ &= (77/2) \text{ cm}^2 \end{aligned}$$

Since the central angles and the radius of each sector are same, area of each sector is  $77/2 \text{ cm}^2$

$$\begin{aligned} \therefore \text{Area of the shaded portion} &= \text{Area of square} - \text{Area of the four sectors} \\ &= 196 - (4 \times (77/2)) \\ &= 196 - 154 \\ &= 42 \text{ cm}^2 \end{aligned}$$

Therefore, required area of the portion enclosed between these pieces is  $42 \text{ cm}^2$ .

**9. On a square cardboard sheet of area  $784 \text{ cm}^2$ , four congruent circular plates of maximum size are placed such that each circular plate touches the other two plates and each side of the square sheet is tangent to two circular plates. Find the area of the square sheet not covered by the circular plates.**

**Solution:**

According to the question,

$$\text{Area of the square} = 784 \text{ cm}^2$$

$$\therefore \text{Side of the square} = \sqrt{\text{Area}} = \sqrt{784} = 28 \text{ cm}$$

The four circular plates are congruent,

$$\text{Then diameter of each circular plate} = 28/2 = 14 \text{ cm}$$

$$\therefore \text{Radius of each circular plate} = 7 \text{ cm}$$

We know that,

$$\text{Area of the sheet not covered by plates} = \text{Area of the square} - \text{Area of the four circular plates}$$

As all four circular plates are congruent,

We have, area of all four plates equal.

## Class 10 Maths Chapter 11-Area Related To Circles

$\therefore$  Area of one circular plate =  $\pi r^2 = (22/7) \times 7^2 = 154 \text{ cm}^2$

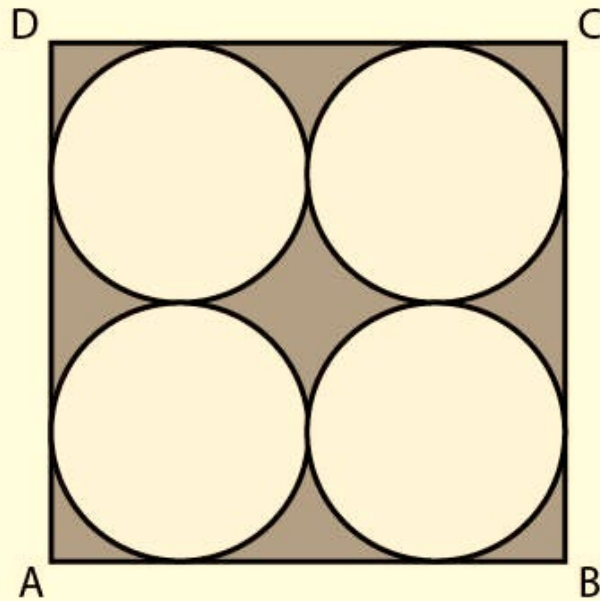

Then,

Area of four plates =  $4 \times 154 = 616 \text{ cm}^2$

Area of the sheet not covered by plates =  $784 - 616 = 168 \text{ cm}^2$

mc<sup>24</sup>

Myclass24  
Your Class. Your Pace.