

# NCERT Solutions for Class-XI Physics

## Chapter-14

### NCERT Biology Class 11

- Which of the following examples represent periodic motion?
  - A swimmer completing one (return) trip from one bank of a river to the other and back.
  - A freely suspended bar magnet displaced from its N-S direction and released.
  - A hydrogen molecule rotating about its center of mass.
  - An arrow released from a bow.

1. (b) and (c).  
(Swimmer does not repeat trip after regular interval of time. Similarly, arrow released from a bow is not periodic).
- Which of the following examples represent (nearly) simple harmonic motion and which represent periodic but not simple harmonic motion?
  - the rotation of earth about its axis.
  - motion of an oscillating mercury column in a U-tube.
  - motion of a ball bearing inside a smooth curved bowl, when released from a point slightly above the lower most point.
  - general vibrations of a polyatomic molecule about its equilibrium position.

2. (a) Since the rotation of earth is not to and fro motion about a fixed point, thus it is periodic but not S.H.M.  
(b) It is S.H.M.  
(c) It is S.H.M.  
(d) General vibrations of a polyatomic molecule about its equilibrium position is periodic but non SHM. In fact, it is a result of superposition of SHMs executed by individual vibrations of atoms of the molecule.
- Figure depicts four  $x-t$  plots for linear motion of a particle. Which of the plots represents periodic motion? What is the period of motion (in case of periodic motion)?
  -

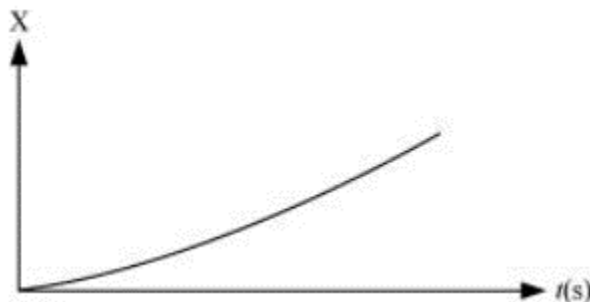

(b)

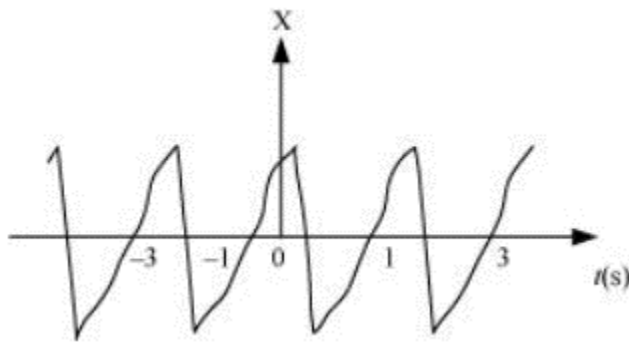

(c)

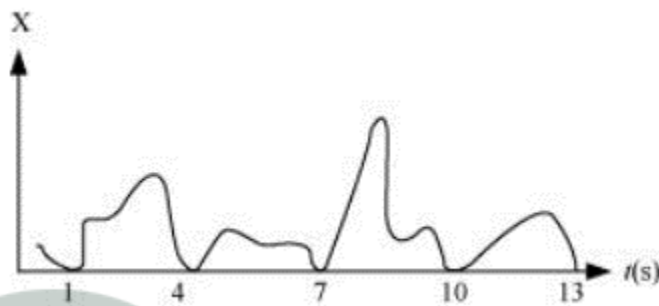

(d)

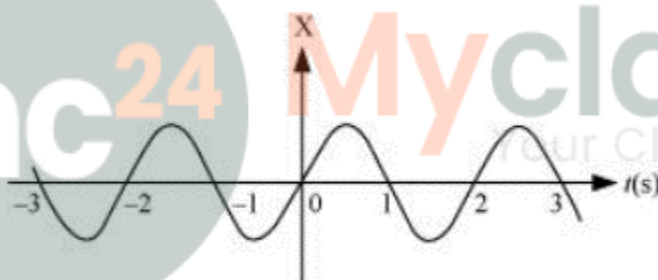

3. Fig (b) and (d) represent periodic motions and the time period of each of these is 2 second, (a) and (c) are non periodic motions.

4. Which of the following functions of time represent (a) simple harmonic, (b) periodic but not simple harmonic, and (c) non-periodic motion ? Give period for each case of periodic motion : ( $\omega$  is any positive constant).

(a)  $\sin \omega t - \cos \omega t$

(b)  $\sin^2 \omega t$

(c)  $3 \cos (\pi/4 - 2\omega t)$

(d)  $\cos \omega t + \cos 3\omega t + \cos 5\omega t$

(e)  $\exp (-\omega^2 t^2)$

(f)  $1 + \omega t + \omega^2 t^2$

4. (a)  $\sin \omega t - \cos \omega t$

Since the above function is of form  $A \sin(\omega t + \phi)$  it represents SHM with a time period of  $\frac{2\pi}{\omega}$ .

(b)  $\sin^2 \omega t$

The two functions individually represent SHM but their superposition does not give rise to SHM but the motion will definitely be periodic with a period of  $\frac{2\pi}{\omega}$

(c)  $3 \cos (\pi/4 - 2\omega t)$

The function represents SHM with a period of  $\frac{\pi}{\omega}$

(d)  $\cos \omega t + \cos 3\omega t + \cos 5\omega t$

Here each individual functions are SHM. But superposition is not SHM. The function represents periodic motion but not SHM.

$$\text{period} = \text{LCM} \left( \frac{2\pi}{\omega}, \frac{2\pi}{3\omega}, \frac{2\pi}{5\omega} \right) = \frac{2\pi}{\omega}$$

(e)  $\exp (-\omega^2 t^2)$

The given function is exponential and therefore does not represent periodic motion.

(f)  $1 + \omega t + \omega^2 t^2$

The given function does not represent periodic motion.

5. A particle is in linear simple harmonic motion between two points, A and B, 10 cm apart. Take the direction from A to B as the positive direction and give the signs of velocity, acceleration and force on the particle when it is (a) at the end A, (b) at the end B, (c) at the mid-point of AB going towards A, (d) at 2 cm away from B going towards A, (e) at 3 cm away from A going towards B, and (f) at 4 cm away from A going towards A.
5. A and B form the extreme positions and the center of line AB (let it be O) forms the mean position.

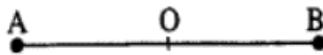

- (a) At the end A, e., extreme position, velocity is zero, acceleration and force are directed towards O and are positive.
- (b) At the end B, e., second extreme position, velocity is zero whereas the acceleration and force are directed towards the point O and are negative.
- (c) At the mid point O, while going towards A, velocity is negative and maximum. The acceleration and force are both zero.
- (d) At a distance 2 cm away from B going towards A, velocity is negative. Since acceleration and force are also directed towards O, both of them are negative.
- (e) At a distance 3 cm away from A going towards B, velocity is positive. Since the acceleration and force are directed towards O from A, both of these are positive.
- (f) At a distance of 4 cm away from A and going towards A, velocity is directed along BA, therefore, it is positive. Since acceleration and force are directed towards OB, both of them are positive.
6. Which of the following relationships between the acceleration  $a$  and the displacement  $x$  of a particle involve simple harmonic motion ?
- (a)  $a = 0.7x$       (b)  $a = -200x^2$       (c)  $a = -10x$       (d)  $a = 100^3$

6. Only (c) i.e.,  $a = -10x$  represents SHM. This is because acceleration is proportional and opposite to displacement ( $x$ ).

7. The motion of a particle executing simple harmonic motion is described by the displacement function,  $x(t) = A \cos(\omega t + \Phi)$

If the initial ( $t = 0$ ) position of the particle is 1 cm and its initial velocity is 0 cm/s, what are its amplitude and initial phase angle? The angular frequency of the particle is  $n \text{ s}^{-1}$ . If instead of the cosine function, we choose the sine function to describe the SHM :  $x = B \sin(\omega t + \alpha)$ , what are the amplitude and initial phase of the particle with the above initial conditions ?

7. Initially, at  $t = 0$  : Displacement,  $x = 1 \text{ cm}$

Initial velocity,  $v = 0 \text{ cm/sec.}$  and Angular frequency,  $\omega = \pi \text{ rad/s}^{-1}$

It is given that:  $x(t) = A \cos(\omega t + \phi)$

$$1 = A \cos(\omega \times 0 + \phi) = A \cos \phi \Rightarrow A \cos \phi = 1$$

Velocity,  $v = \frac{dx}{dt}$

$$\omega = -A \omega \sin(\omega t + \phi)$$

$$0 = -A \omega \sin(\omega \times 0 + \phi) = -A \omega \sin \phi$$

$$A \sin \phi = 0$$

Squaring and adding equations (i) and (ii), we get:  $A^2(\sin^2 \phi + \cos^2 \phi) = 1 + 0 \Rightarrow A^2 = 1 \Rightarrow A = 1 \text{ cm}$

$$\therefore \phi = \frac{3\pi}{4}, \frac{7\pi}{4}, \dots$$

SHM is given as:  $X = B \sin(\omega t + \alpha)$

Putting the given values in this equation, we get:  $1 = B \sin[\omega \times 0 + \alpha] \Rightarrow B \sin \alpha = 1 \dots(iii)$

Velocity,  $V = \omega B \cos(\omega t + \alpha)$

Substituting the given values, we get:  $0 = \omega B \cos \alpha \Rightarrow B \cos \alpha = 0 \dots(iv)$

Squaring and adding equations (iii) and (iv), we get:  $B^2[\sin^2 \alpha + \cos^2 \alpha] = 1 + 0 \Rightarrow B^2 = 1 \Rightarrow B = 1 \text{ cm}$

Dividing equation (iii) by equation (iv), we get:  $\frac{B \sin \alpha}{B \cos \alpha} = \frac{1}{0} \Rightarrow \tan \alpha = \infty = \tan \frac{\pi}{2}$

$$\therefore \alpha = \frac{\pi}{2}, \frac{5\pi}{2}, \dots$$

8. A spring balance has a scale that reads from 0 to 50 kg. The length of the scale is 20 cm. A body suspended from this balance, when displaced and released, oscillates with a period of 0.6 s. What is the weight of the body?

8. Maximum mass that the scale can read,  $M = 50 \text{ kg}$

Maximum displacement of the spring = Length of the scale,  $l = 20 \text{ cm} = 0.2 \text{ m}$

Time period,  $T = 0.6 \text{ s}$  and Maximum force exerted on the spring,  $F = Mg$

Where,  $g = \text{acceleration due to gravity} = 9.8 \text{ m/s}^2$

$$F = 50 \times 9.8 = 490$$

$$\therefore \text{Spring constant, } k = \frac{F}{l} = \frac{490}{0.2} = 2450 \text{ Nm}^{-1}$$

Mass  $m$ , is suspended from the balance. Time period,  $T = 2\pi\sqrt{\frac{m}{k}}$

$$\therefore m = \left(\frac{T}{2\pi}\right)^2 \times k = \left(\frac{0.6}{2 \times 3.14}\right)^2 \times 2450 = 22.36 \text{ kg}, \therefore \text{Weight} = mg = 22.36 \times 9.8 = 219.167 \text{ N}$$

Hence, the weight of the body is about 219 N.

9. A spring with a spring constant  $1200 \text{ N m}^{-1}$  is mounted on a horizontal table as shown in Fig. A mass of  $3 \text{ kg}$  is attached to the free end of the spring. The mass is then pulled sideways to a distance of  $2.0 \text{ cm}$  and released. Determine

- (a) the frequency of oscillations,  
 (b) maximum acceleration of the mass, and  
 (c) the maximum speed of the mass.

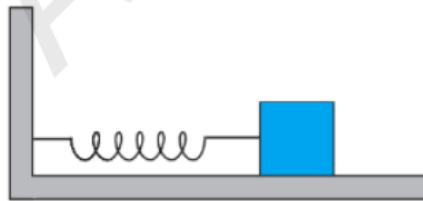

9. Here  $k = 1200 \text{ N m}^{-1}$ ,  $m = 3 \text{ kg}$ ,  $A = 2.0 \text{ cm} = 2 \times 10^{-2} \text{ m}$

- (a) Frequency of oscillations is given by

$$v = \frac{1}{2\pi} \sqrt{\frac{k}{m}} = \frac{1}{2\pi} \times \sqrt{\frac{1200}{3}} = \frac{20}{2 \times 3.14} = 3.19 \text{ s}^{-1}$$

- (b) The maximum acceleration is

$$a_{\text{max}} = \omega^2 A = 4\pi^2 v^2 A = 4 \times (3.14)^2 \times (3.19)^2 \times 2 \times 10^{-2} = 8.02 \text{ ms}^{-2}$$

- (c) maximum speed is

$$v_{\text{max}} = A\omega = 2 \times 10^{-2} \times 2\pi v = 2 \times 10^{-2} \times 2 \times 3.14 \times 3.19 = 0.4 \text{ ms}^{-1}$$

10. In Exercise 9, let us take the position of mass when the spring is unstretched as  $x = 0$ , and the direction from left to right as the positive direction of  $x$ -axis. Give  $x$  as a function of time  $t$  for the oscillating mass if at the moment we start the stopwatch ( $t = 0$ ), the mass is
- at the mean position,
  - at the maximum stretched position, and
  - at the maximum compressed position.

In what way do these functions for SHM differ from each other, in frequency, in amplitude or the initial phase ?

10. Here, the maximum displacement = Amplitude  $A = 2$  cm

(a) If the time  $t = 0$  at  $x = 0$ , the displacement can be expressed as the sine function of  $t$ .

$$x(t) = A \sin \omega t$$

$$\text{But } \omega = \sqrt{\frac{k}{m}} = \sqrt{\frac{1200}{3}} = 20 \text{ rad s}^{-1}$$

$$\therefore x(t) = 2 \sin 20t$$

(b) If the time  $t = 0$  at  $x = 2$  cm (i.e., positive extreme position), the displacement is expressed as the cosine function.

$$\therefore x(t) = 2 \cos 20t$$

(c) If the time  $t = 0$  at  $x = -2$  cm (i.e., negative extreme position), the displacement is expressed as the cosine function given by

$$x(t) = -2 \cos 20t$$

The above functions have same value of frequency and amplitude but they differ in phase.

11. Following figures correspond to two circular motions. The radius of the circle, the period of revolution, the initial position, and the sense of revolution (i.e clockwise or anti-clockwise) are indicated on each figure.

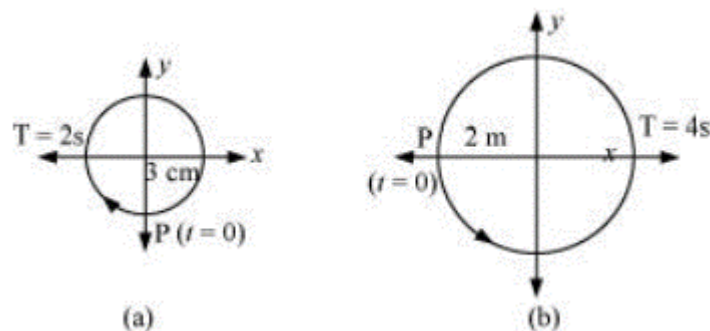

Obtain the corresponding simple harmonic motions of the  $x$ -projection of the radius vector of the revolving particle  $P$  in each case.

11. (a) Let  $A$  be any point on the circle of reference of the fig. (a). From  $A$ , draw  $AM$  perpendicular on  $x$ -axis.

If  $\angle POA = \theta$ , then

$$\angle OAM = \theta = \omega t$$

∴ In triangle OAM,

$$\frac{OM}{OA} = \sin \theta$$

$$\therefore \frac{-x}{3} = \sin \theta = \sin \frac{2\pi}{T} t \quad [x \text{ is negative in fourth quadrant}]$$

$$\therefore x = -3 \sin \frac{2\pi}{2} t \text{ or } x = -3 \sin \pi t$$

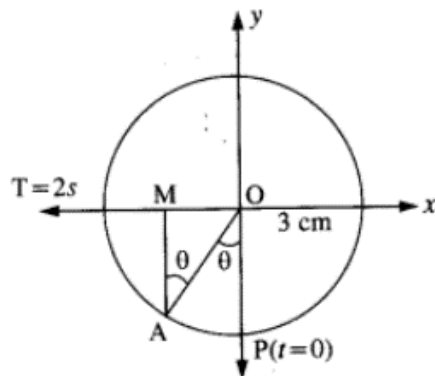

which is the equation of SHM.

(b) Let B be any point on the circle of reference of fig. (b). From B, draw BN perpendicular on x-axis.

Then  $\angle BON = \theta = \omega t$

$$\therefore \text{In } \triangle ONB, \cos \theta = \frac{ON}{OB}$$

$$\text{Or } ON = OB \cos \theta$$

$$\therefore -x = 2 \cos \omega t \Rightarrow x = -2 \cos \frac{2\pi}{T} t = -2 \cos \frac{2\pi}{4} t$$

$$\therefore x = -2 \cos \frac{\pi}{2} t \text{ which is equation of SHM}$$

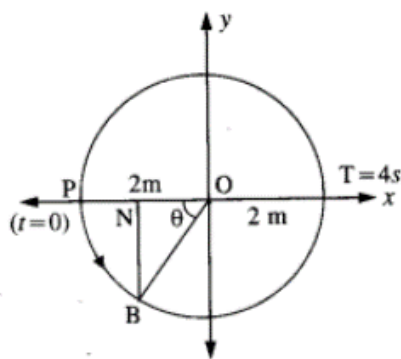

12. Plot the corresponding reference circle for each of the following simple harmonic motions. Indicate the initial ( $t = 0$ ) position of the particle, the radius of the circle, and the angular speed of the rotating particle. For simplicity, the sense of rotation may be fixed to be anticlockwise in every case (or is in cm and  $t$  is in s):

(a)  $x = -2 \sin (3t + \pi/3)$

(b)  $x = \cos (\pi/6 - t)$

(c)  $x = 3 \sin (2nt + tc/4)$

(d)  $x = 2 \cos \pi t$

12.

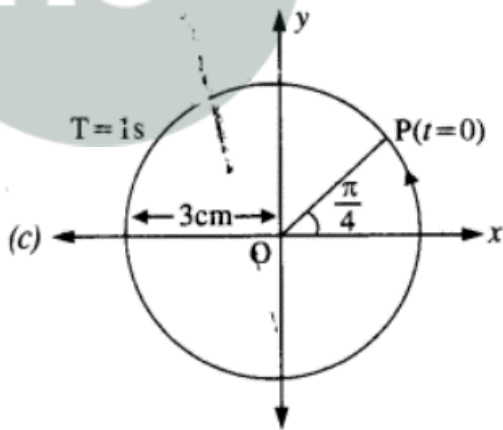
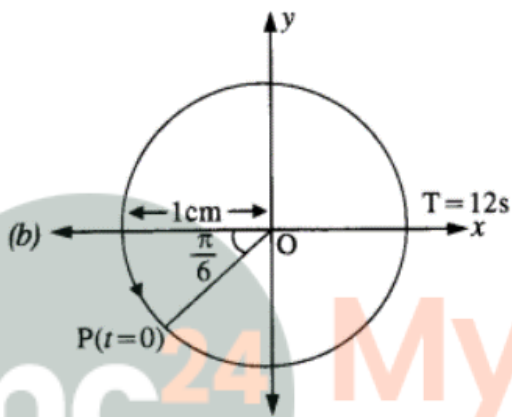
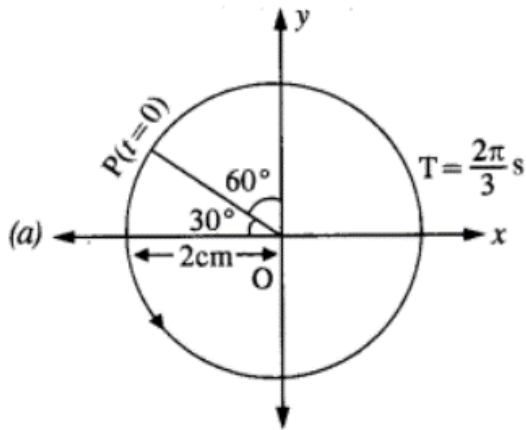

mc24 Myclass24  
Your Class. Your Pace.

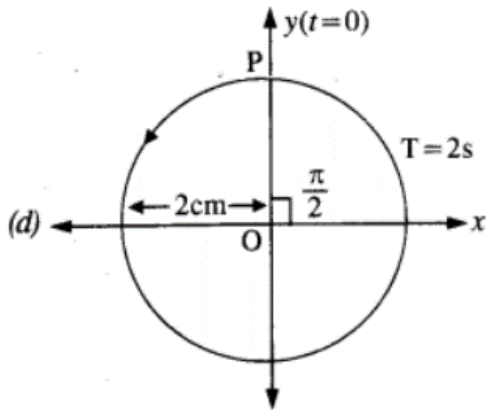

13. Figure (a) shows a spring of force constant  $k$  clamped rigidly at one end and a mass  $m$  attached to its free end. A force  $F$  applied at the free end stretches the spring. Figure (b) shows the same spring with both ends free and attached to a mass  $m$  at either end. Each end of the spring in Fig. (b) is stretched by the same force  $F$ .

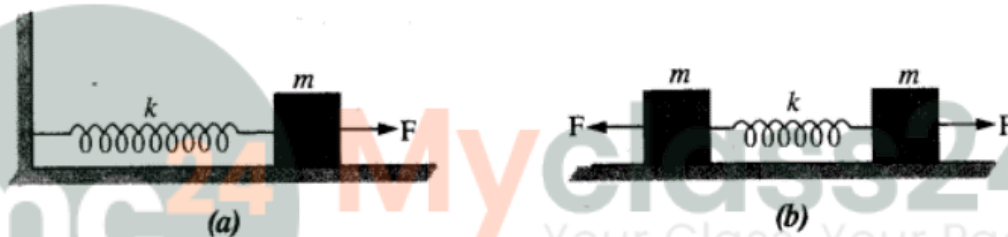

- (a) What is the maximum extension of the spring in the two cases ?  
 (b) If the mass in Fig. (a) and the two masses in Fig. (b) are released free, what is the period of oscillation in each case ?
13. (a) Let  $y$  be the maximum extension produced in the spring in fig. (a).  
 Then  $F = Ay$  (in magnitude)

$$\therefore y = \frac{F}{K}$$

In fig. (b), the force on one mass acts as the force of reaction due to the force on the other mass. Therefore, each mass behaves as if it is fixed with respect to the other.

$$\text{Therefore, } F = ky \Rightarrow y = \frac{F}{k}$$

(b) In fig. (a),  $F = -ky$

$$\Rightarrow ma = -ky \Rightarrow a = -\frac{k}{m}y$$

$$\therefore \omega^2 = \frac{k}{m} \text{ i.e., } \omega = \sqrt{\frac{k}{m}}$$

$$\text{Therefore, period } T = \frac{2\pi}{\omega} = 2\pi\sqrt{\frac{m}{k}}$$

In fig. (b), we may consider that the centre of the system is O and there are two springs each of length  $\frac{l}{2}$  attached to the two masses, each m, so that  $k'$  is the spring factor of each of the springs.



Then,  $k' = 2k$

$$T = 2\pi\sqrt{\frac{m}{k'}} = 2\pi\sqrt{\frac{m}{2k}}$$

14. The piston in the cylinder head of a locomotive has a stroke (twice the amplitude) of 1.0 m. If the piston moves with simple harmonic motion with an angular frequency of 200 rev/min, what is its maximum speed?

14. Angular frequency of the piston,  $\omega = 200$  rad/min

Stroke = 1.0 m

Amplitude,  $A = \frac{1.0}{2} = 0.5$  m

The maximum speed ( $v_{\max}$ ) of the piston is given by the relation:

$$v_{\max} = A\omega = 200 \times 0.5 = 100 \text{ m/min}$$

15. The acceleration due to gravity on the surface of moon is  $1.7 \text{ ms}^{-2}$ . What is the time period of a simple pendulum on the surface of moon if its time period on the surface of earth is 3.5 s? ( $g$  on the surface of earth is  $9.8 \text{ ms}^{-2}$ )

15.  $T = 2\pi\sqrt{l/g}$

$$\frac{T_m}{T_e} = \sqrt{\frac{g_e}{g_m}} = 2.38$$

$$T_m = 2.38T_e = 2.38 \times 3.5 = 8.33 \text{ s}$$

16. Answer the following questions :

(a) Time period of a particle in SHM depends on the force constant  $k$  and mass  $m$  of the particle :

$$T = 2\pi\sqrt{\frac{m}{k}}$$

A simple pendulum executes SHM approximately. Why then is the time period of a pendulum independent of the mass of the pendulum ?

(b) The motion of a simple pendulum is approximately simple harmonic for small angle oscillations. For larger angles of oscillation, a more involved analysis shows that  $T$  is greater than

$$2\pi\sqrt{\frac{l}{g}}$$

Think of a qualitative argument to appreciate this result.

(c) A man with a wristwatch on his hand falls from the top of a tower. Does the watch give correct time during the free fall ?

(d) What is the frequency of oscillation of a simple pendulum mounted in a cabin that is freely falling under gravity

16. (a) In case of spring, the spring constant is independent of the mass attached whereas in case of a pendulum  $k$  is proportional to  $m$  making  $k/m$  constant and thus the time period comes out to be independent of the mass of the body attached.

(b) In reaching the result  $T = 2\pi\sqrt{\frac{l}{g}}$  we have assumed  $\sin(x/l) = x/l$ . This assumption is

only true for very small values of  $x$  (or  $\theta$ ) Therefore it is obvious that once  $x$  takes larger values we will have deviations from the above-mentioned value.

(c) The watch must be using an electrical circuit or a spring system to tell the time and therefore free falling would not affect the time his watch predicts.

(d) While free falling the effective value of  $g$  inside the cabin will be zero and therefore the frequency of oscillation of a simple pendulum would be zero i.e. it would not vibrate at all because of the absence of a restoring force.

17. A simple pendulum of length  $l$  and having a bob of mass  $M$  is suspended in a car. The car is moving on a circular track of radius  $R$  with a uniform speed  $v$ . If the pendulum makes small oscillations in a radial direction about its equilibrium position, what will be its time period?

17. In this case, the bob of the pendulum is under the action of two accelerations.

(a) Acceleration due to gravity ' $g$ ' acting vertically downwards.

(b) Centripetal acceleration  $a_c = \frac{v^2}{R}$  acting along the horizontal direction.

$\therefore$  Effective acceleration,  $g' = \sqrt{g^2 + a_c^2}$  or  $g' = \sqrt{g^2 + \frac{v^2}{R^2}}$

$\therefore$  New time period,  $T' = 2\pi\sqrt{\frac{l}{g'}} = 2\pi\sqrt{\frac{l}{\sqrt{g^2 + \frac{v^2}{R^2}}}}$

18. A cylindrical piece of cork of base area  $A$  and height  $h$  floats in a liquid of density  $\rho$ . The cork is depressed slightly and then released. Show that the cork oscillates up and down simple harmonically with a period

$$T = 2\pi\sqrt{\frac{h\rho}{\rho_L g}}$$

where  $\rho$  is the density of cork. (Ignore damping due to viscosity of the liquid).

18. Base area of the cork =  $A$  and Height of the cork =  $h$

Density of the liquid =  $\rho_l$  and Density of the cork =  $\rho$

In equilibrium: Weight of the cork = Weight of the liquid displaced by the floating cork

Let the cork be depressed slightly by  $x$ . As a result, some extra water of a certain volume is displaced.

Hence, an extra up-thrust acts upward and provides the restoring force to the cork.

Up-thrust = Restoring force,  $F = \text{Weight of the extra water displaced}$

$$\Rightarrow F = -(\text{Volume} \times \text{Density} \times g)$$

Volume = Area  $\times$  Distance through which the cork is depressed

$$\text{Volume} = Ax, \therefore F = -A \times \rho l g$$

$$\text{According to the force law: } F = kx \Rightarrow k = \frac{F}{x}$$

$$\text{Where, } k \text{ is a constant. So, } k = \frac{F}{x} = -A\rho_1 g \dots \text{(ii)}$$

$$\text{The time period of the oscillations of the cork: } T = 2\pi \sqrt{\frac{m}{k}} \dots \text{(iii)}$$

Where,  $m = \text{Mass of the cork} = \text{Volume of the cork} \times \text{Density}$

$$= \text{Base area of the cork} \times \text{Height of the cork} \times \text{Density of the cork} = Ah\rho$$

$$\text{Hence, the expression for the time period becomes: } T = 2\pi \sqrt{\frac{Ah\rho}{Ah\rho_1 g}} = 2\pi \sqrt{\frac{h\rho}{\rho_1 g}}$$

**19.** One end of a U-tube containing mercury is connected to a suction pump and the other end to atmosphere. A small pressure difference is maintained between the two columns. Show that, when the suction pump is removed, the column of mercury in the U-tube executes simple harmonic motion.

**19.** The suction pump creates the pressure difference, thus mercury rises in one limb of the U-tube. When it is removed, a net force acts on the liquid column due to the difference in levels of mercury in the two limbs and hence the liquid column executes S.H.M. which can be expressed as:

Consider the mercury contained in a vertical U-tube upto the level P and Q in its two limbs.

Let  $P = \text{density of the mercury.}$

$L = \text{Total length of the mercury column in both the limbs.}$

$A = \text{internal cross-sectional area of U-tube. } m = \text{mass of mercury in U-tube} = LAP.$

Assume, the mercury be depressed in left limb to F by a small distance  $y$ , then it rises by the same amount in the right limb to position Q'.

$$\therefore \text{Difference in levels in the two limbs} = P'Q' = 2y.$$

$$\therefore \text{Volume of mercury contained in the column of length } 2y = A \times 2y$$

$$\therefore m = A \times 2y \times \rho.$$

If  $W = \text{weight of liquid contained in the column of length } 2y.$

$$\text{Then } W = mg = A \times 2y \times \rho \times g$$

This weight produces the restoring force ( $F$ ) which tends to bring back the mercury to its equilibrium position.

$$\therefore F = -2Aypg = -(2A\rho g)y$$

If  $a = \text{acceleration produced in the liquid column, Then}$

$$a = \frac{F}{m} = \frac{-(2A\rho g)y}{LA\rho} = -\frac{2A\rho g}{LA}$$

$$= -\frac{2\rho g}{2h} y \quad \dots \text{(i) } (\because L = 2h)$$

where  $h$  = height of mercury in each lim. Now from equation (i), it is clear that  $a \propto y$  and positive sign shows that it acts opposite to  $y$ , so the motion of mercury in u-tube is simple harmonic in nature having time period ( $T$ ) given by

$$T = 2\pi\sqrt{\frac{y}{a}} = 2\pi\sqrt{\frac{2h\rho}{2\rho g}} = 2\pi\sqrt{\frac{h\rho}{\rho g}}$$

$$T = 2\pi\sqrt{\frac{h}{g}}$$

20. An air chamber of volume  $V$  has a neck area of cross-section  $a$  into which a ball of mass  $m$  can move up and down without any friction (Fig.). Show that when the ball is pressed down a little and released, it executes SHM. Obtain an expression for the time period of oscillations assuming pressure-volume variations of air to be isothermal [see Fig.]

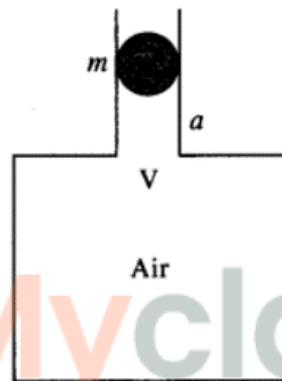

(negative sign shows a decrease in volume)

20. Let the initial volume and pressure of the chamber be  $V$  and  $P$ .  
 Let the ball be pressed by a distance  $x$ .  
 This will change the volume by an amount  $ax$ .  
 Let the change in pressure be  $\Delta P$   
 Let the Bulk's modulus of air be  $K$ .

$$K = \frac{\Delta P}{\Delta V/V}$$

$$\Delta P = \frac{Kax}{V}$$

This pressure variation would try to restore the position of the ball.

Since force is restoring in nature displacement and acceleration due to the force would be in different directions.

The above is the equation of a body executing S.H.M.

The time period of the oscillation would be

$$T = \frac{2\pi}{a} \sqrt{\frac{mV}{k}}$$

21. You are riding in an automobile of mass 3000 kg. Assuming that you are examining the oscillation characteristics of its suspension system. The suspension sags 15 cm when the entire automobile is placed on it. Also, the amplitude of oscillation decreases by 50%

during one complete oscillation. Estimate the values of (a) the spring constant  $k$  and (b) the damping constant  $b$  for the spring and shock absorber system of one wheel, assuming that each wheel supports 750 kg.

21. (a) Here, mass  $M = 3000$  kg, displacement  $x = 15$  cm = 0.15 m,  $g = 10$  m/s<sup>2</sup>. There are four spring systems. If  $k$  is the spring constant of each spring, then total spring constant of all the four springs in parallel is

$$k_p = 4k \quad \therefore Mg = k_p x = 4kx$$

$$\Rightarrow k = \frac{Mg}{4x} = \frac{3000 \times 10}{4 \times 0.15} = 5 \times 10^4 \text{ N}$$

- (b) For each spring system supporting =  $\frac{3000}{4} = 750$  kg of weight,

$$t = 2\pi \sqrt{\frac{m}{k}} = 2 \times 3.14 \times \sqrt{\frac{750}{5 \times 10^4}} = 0.77 \text{ sec}$$

$$\therefore \text{Using } x = x_0 e^{-\frac{bt}{2m}}, \text{ we get } \frac{50}{100} x_0 = x_0 e^{-\frac{b \times 0.77}{2 \times 750}} \text{ or } e^{\frac{0.77b}{1500}} = 2$$

Taking natural logarithm of both sides,

$$\frac{0.77b}{1500} = \log_e 2 = 2.303 \log 2$$

$$\therefore b = \frac{1500}{0.77} \times 2.303 \times 0.3010 = 1350.4 \text{ kg s}^{-1}$$

22. Show that for a particle in linear SHM the average kinetic energy over a period of oscillation equals the average potential energy over the same period.

22. The equation of displacement of a particle executing SHM at an instant  $t$  is given as:

$$x = A \sin \omega t$$

Where,  $A$  = Amplitude of oscillation and  $\omega$  = Angular frequency =  $\sqrt{\frac{k}{M}}$

The velocity of the particle is  $v = \frac{dx}{dt} = A\omega \cos \omega t$

The kinetic energy of the particle is  $E_k = \frac{1}{2} M v^2 = \frac{1}{2} M A^2 \omega^2 \cos^2 \omega t$

The potential energy of the particle is  $E_p = \frac{1}{2} k x^2 = \frac{1}{2} M \omega^2 A^2 \sin^2 \omega t$

For time period  $T$ , the average kinetic energy over a single cycle is given as:

$$\begin{aligned} (E_k)_{\text{Avg}} &= \frac{1}{T} \int_0^T E_k dt = \frac{1}{T} \int_0^T \frac{1}{2} M A^2 \omega^2 \cos^2 \omega t dt \\ &= \frac{1}{2T} M A^2 \omega^2 \int_0^T \frac{(1 + \cos 2\omega t)}{2} dt \\ &= \frac{1}{2T} M A^2 \omega^2 \left[ t + \frac{\sin 2\omega t}{2\omega} \right]_0^T = \frac{1}{4T} M A^2 \omega^2 (T) = \frac{1}{4} M A^2 \omega^2 \dots(i) \end{aligned}$$

And, average potential energy over one cycle is given as:

$$\begin{aligned} (E_p)_{\text{Avg}} &= \frac{1}{T} \int_0^T E_p dt = \frac{1}{T} \int_0^T \frac{1}{2} M \omega^2 A^2 \sin^2 \omega t dt = \frac{1}{2T} M \omega^2 A^2 \int_0^T \frac{(1 - \cos 2\omega t)}{2} dt \\ &= \frac{1}{4T} M \omega^2 A^2 \left[ t - \frac{\sin 2\omega t}{2\omega} \right]_0^T = \frac{1}{4T} M \omega^2 A^2 (T) = \frac{M \omega^2 A^2}{4} \end{aligned}$$

It can be inferred from equations (i) and (ii) that the average kinetic energy for a given time period is equal to the average potential energy for the same time period.

- 23.** A circular disc of mass 10 kg is suspended by a wire attached to its center. The wire is twisted by rotating the disc and released. The period of torsional oscillations is found to be 1.5 s. The radius of the disc is 15 cm. Determine the torsional spring constant of the wire. (Torsional spring constant  $a$  is defined by the relation  $J = -a\theta$ , where  $J$  is the restoring couple and  $\theta$  the angle of twist).

- 23.** Here, mass of disc,  $m = 10$  kg,  
radius  $r = 15$  cm = 0.15 m Torsional spring constant  $a = ?$   
Time period of torsional oscillations,  $T = 1.5$  s

$$\text{Using } T = 2\pi\sqrt{\frac{I}{C}} \quad \Rightarrow \quad C = \frac{4\pi^2 I}{T^2}$$

Here  $I =$  moment of inertia of disc

$$= \frac{1}{2}mr^2 = \frac{1}{2} \times 10 \times (0.15)^2 = 0.1125 \text{ kg m}^2$$

$$\therefore C = \frac{4 \times 9.87 \times 0.1125}{(1.5)^2} = 1.974 \text{ NM rad}^{-1} = 2.0 \text{ Nm rad}^{-1}$$

- 24.** A body describes a S.H.M. with an amplitude of 5 cm and period of 0.2 s. Find the acceleration and velocity of the body, when displacement is (a) 5 cm, (b) 3 cm, (c) 0 cm.

- 24.**  $A = 5$  cm,  $T = 0.2$  s.

$$\text{Now, } v = \omega\sqrt{A^2 - x^2} = \frac{2\pi}{T}\sqrt{A^2 - x^2}$$

(i) When  $x = 5$  cm,  $v = 0$

(ii) When  $x = 3$  cm,  $v = \frac{2 \times 3.14}{0.2} \sqrt{25 - 9} = 31.4 \times 4 = 125.6 \text{ cm s}^{-1}$

(iii) When  $x = 0$ ,  $v = \frac{2 \times 3.14}{0.2} \times 5 = 157 \text{ cm s}^{-1}$

$$\text{Acceleration, } a = -\omega^2 x = -\frac{4\pi^2 x}{T^2}$$

(i) When  $x = 5$  cm,  $a = -\frac{4 \times (3.14)^2}{0.04} \times 5 = -19719 \text{ cm s}^{-2} = -197.19 \text{ m s}^{-2}$

(ii) When  $x = 3$  cm,  $a = -\frac{4 \times (3.14)^2}{0.04} \times 3 = 11831 \text{ cm s}^{-2} = -118.31 \text{ m s}^{-2}$

(iii) When  $x = 0$ ,  $a = 0$ .

- 25.** A mass attached to a spring is free to oscillate with angular velocity  $\omega$  in a horizontal plane without friction or damping. It is pulled to a distance  $x_0$  and pushed towards the center with velocity  $v_0$  at time  $t = 0$ . Determine the amplitude of the resulting oscillations in terms of the parameters  $\omega$ ,  $x_0$  and  $v_0$ .

- 25.** According to the law of conservation of energy

Total energy at  $x_0$  = Total energy at extreme position.

$$\text{i.e., } \frac{1}{2}mv_0^2 + \frac{1}{2}kx_0^2 = \frac{1}{2}KA^2$$

$$A^2 = \frac{mv_0^2}{K} + x_0^2$$

$$\text{Since } \frac{K}{m} = \omega^2$$

$$\therefore A^2 = \frac{v_0^2}{\omega^2} + x_0^2 \text{ or } A = \sqrt{\frac{v_0^2}{\omega^2} + x_0^2}$$



**Myclass24**  
Your Class. Your Pace.